

Notice is hereby given that the Rainbow Municipal Water District Board of Directors will hold Closed Session at 12:30 p.m. and Open Session at 1:00 p.m. Tuesday, September 22, 2016, at the District Office located at 3707 Old Highway 395, Fallbrook, CA 92028. At any time during the session, the Board of Directors Meeting may adjourn to Closed Session to consider litigation or to discuss with legal counsel matters within the attorney client privilege.

AGENDA

1. **CALL TO ORDER**
 2. **ROLL CALL: Sanford____ Walker_____ Brazier_____ Bigley___ Stewart_____**
 3. **ADDITIONS/DELETIONS/AMENDMENTS TO THE AGENDA (Government Code §54954.2)**
 4. **ORAL/WRITTEN COMMUNICATIONS FROM THE PUBLIC
OPPORTUNITY FOR MEMBERS OF THE PUBLIC TO ADDRESS THE BOARD REGARDING
CLOSED SESSION AGENDA ITEMS (Government Code § 54954.2).**
Under Oral Communications, any person wishing to address the Board on matters regarding the Closed Session agenda should indicate their desire to speak by filling out and submitting a "Speaker's Slip" to the Board Secretary before the meeting begins. *Speaking time shall generally be limited to three minutes, unless a longer period is permitted by the Board President.*
 5. **CLOSED SESSION**
 - A. Conference with Legal Counsel—Anticipated Litigation (Government Code section 54956.9(d)(2))
 - * Significant exposure to litigation - 1 matter
 6. **REPORT ON POTENTIAL ACTION FROM CLOSED SESSION**
- Time Certain: 1:00 p.m.
7. **PLEDGE OF ALLEGIANCE**
 8. **REPEAT REPORT ON POTENTIAL ACTION FROM CLOSED SESSION**
 9. **REPEAT ADDITIONS/DELETIONS/AMENDMENTS TO THE AGENDA (Government Code §54954.2)**
 10. **ORAL/WRITTEN COMMUNICATIONS FROM THE PUBLIC
OPPORTUNITY FOR MEMBERS OF THE PUBLIC TO ADDRESS THE BOARD REGARDING
ITEMS NOT ON THIS AGENDA (Government Code § 54954.2).**
Under Oral Communications, any person wishing to address the Board on matters not on this agenda should indicate their desire to speak by filling out and submitting a "Speaker's Slip" to the Board Secretary before the meeting begins. *No action will be taken on any oral communications item since such item does not appear on this Agenda, unless the Board of Directors makes a determination that an emergency exists or that the need to take action on the item arose subsequent to posting of the Agenda (Government Code §54954.2). Speaking time shall generally be limited to three minutes, unless a longer period is permitted by the Board President.*

(*) - Asterisk indicates a report is attached.

***11. APPROVAL OF MINUTES**

- A. June 28, 2016 - Regular Board Meeting

12. BOARD OF DIRECTORS' COMMENTS/REPORTS

Directors' comments are comments by Directors concerning District business, which may be of interest to the Board. This is placed on the agenda to enable individual Board members to convey information to the Board and to the public. There is to be no discussion or action taken by the Board of Directors unless the item is noticed as part of the meeting agenda.

- A. President's Report (Director Sanford)
- B. Representative Report (Appointed Representative)
 - 1. SDCWA
 - 2. CSDA
 - 3. LAFCO
 - 4. San Luis Rey Watershed Council
 - 5. Santa Margarita Watershed Council
- C. Meeting, Workshop, Committee, Seminar, Etc. Reports by Directors (AB1234)
- D. Directors Comments

***13. COMMITTEE REPORTS (Approved Minutes have been attached for reference only.)**

- A. Budget and Finance Committee
 - 1. June 14, 2016 Minutes
- B. Communications Committee
 - 1. June 6, 2016 Minutes
- C. Engineering Committee
 - 1. June 1, 2016 Minutes

BOARD ACTION ITEMS

***14. DISCUSSION AND POSSIBLE ACTION ON ADOPTION OF 2016 RMWD DOMESTIC WATER, RECYCLED WATER AND SANITARY SEWER FACILITIES CONSTRUCTION STANDARDS MANUAL**

(The District utilizes a Standards Manual containing general guidelines, design standards, standard specifications, standard drawings and a list of approved materials. The last Standards Manual update took place in 2011. Over a five-year period, the Standards Manual has been revised by Operations and Engineering. Staff has conducted several meetings to go over the Standards Manual and recommend changes. The draft manual was presented to and reviewed by the Engineering Committee. The Engineering Committee voted unanimously to recommend adoption by the District Board.)

***15. DISCUSSION AND POSSIBLE ACTION TO AWARD A PROFESSIONAL SERVICES AGREEMENT WITH NOBEL SYSTEMS, INC. FOR GEOVIEWER ONLINE, GEOVIEWER MOBILE, INFOR ENTERPRISE ASSET MANAGEMENT INTEGRATION, AND SPRINGBROOK CUSTOMER SERVICE SOFTWARE INTEGRATION**

(The professional service agreement encompasses GIS data update services, hosting GeoViewer Online, GeoViewer Mobile, as well as integrations with the District's asset management software (Infor EAM) and financial software (Springbrook). As part of the Strategic Planning process undertaken in 2015, a key outcome was a desire to increase our ability to both manage assets and improve customer service. This contract is one of the outcomes of this process as it will meet a number of key long term objectives.)

(*) - Asterisk indicates a report is attached.

BOARD INFORMATION ITEMS

***16. QUARTERLY STRATEGIC PLAN OBJECTIVES AND GOALS UPDATE**

(The Board of Directors will review the progress that the District is making on these Objectives on a regular basis to ensure that the District remains on track to achieve these Objectives.)

***17. RECEIVE AND FILE INFORMATION AND FINANCIAL ITEMS FOR JUNE 2016**

A. General Manager Comments

1. Meetings, Conferences and Seminar Calendar

B. Communications

1. Ratepayer Letters
2. Staff Training Reports

C. Operations Comments

1. Operations Report

D. Engineering Comments

1. Engineering Report

E. Customer Service Comments

1. Customer Service Report

F. Human Resource & Safety Comments

1. Human Resources Report
2. Organizational Chart

G. Finance Manager Comments

1. Interim Financial Statement
2. Credit Card Breakdown
3. Directors' Expense
4. Check Register
5. Water Purchases & Sales Summary
6. RMWD Sewer Equivalent Dwelling Units (EDU's) Status

18. LIST OF SUGGESTED AGENDA ITEMS FOR THE NEXT REGULAR BOARD MEETING

19. ADJOURNMENT - To Tuesday, August 23, 2016 at 1:00 p.m.

ATTEST TO POSTING:

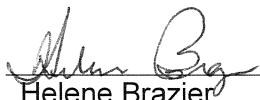

Helene Brazier
Secretary of the Board

7-18-16 @ 1:30 P.M.

Date and Time of Posting
Outside Display Cases

(*) - Asterisk indicates a report is attached.

DRAFT

DRAFT

DRAFT

**MINUTES OF THE REGULAR BOARD MEETING
OF THE BOARD OF DIRECTORS OF THE
RAINBOW MUNICIPAL WATER DISTRICT
JUNE 28, 2016**

1. **CALL TO ORDER** - The Regular Meeting of the Board of Directors of the Rainbow Municipal Water District on June 28, 2016 was called to order by President Sanford at 1:00 p.m. in the Board Room of the District, 3707 Old Highway 395, Fallbrook, CA 92028. President Sanford presiding.

2. **PLEDGE OF ALLEGIANCE**

3. **ROLL CALL:**



Present: Director Sanford, Director Walker, Director Brazier, Director Bigley.

Absent: Director Stewart.

Also Present: General Manager Kennedy, Executive Assistant Washburn, Legal Counsel Stender, Engineering Manager Kirkpatrick, Finance Manager Martinez, Superintendent Maccarrone, Superintendent Walker, Administrative Analyst Gray, Associate Engineer Powers, Human Resources Manager Harp.

No members of the public were present for Open Session.

4. **ADDITIONS/AMENDMENTS TO THE AGENDA (Government Code §54954.2)**

There were no changes to the agenda.

5. **ORAL/Written COMMUNICATIONS FROM THE PUBLIC
OPPORTUNITY FOR MEMBERS OF THE PUBLIC TO ADDRESS THE BOARD REGARDING
ITEMS NOT ON THIS AGENDA (Government Code § 54954.2).**

There were no comments.

*6. **APPROVAL OF MINUTES**

A. May 24, 2016 - Regular Board Meeting



Motion:

Approve the minutes of May 24, 2016 Regular Board meeting.

Action: Approve, Moved by Director Brazier, Seconded by Director Bigley.



Vote: Motion carried by unanimous vote (summary: Ayes = 4).

Ayes: Director Sanford, Director Walker, Director Brazier, Director Bigley.

(*) - Asterisk indicates a report is attached.

DRAFT

DRAFT

DRAFT

Absent: Director Stewart.

7. BOARD OF DIRECTORS' COMMENTS/REPORTS

Directors' comments are comments by Directors concerning District business, which may be of interest to the Board. This is placed on the agenda to enable individual Board members to convey information to the Board and to the public. There is to be no discussion or action taken by the Board of Directors unless the item is noticed as part of the meeting agenda.



A. President's Report (Director Sanford)

There was no report given.

B. Representative Report (Appointed Representative)

1. SDCWA

A. Summary of Formal Board of Directors' Meeting May 26, 2016

Mr. Kennedy noted SDCWA approved rates at the last meeting which would be the same rate structure Mrs. Martinez will describe during the budget review later in the meeting. He also announced SDCWA cancelled all the drought restrictions with the exception of the State's list of mandatory requirements. He commented on the Gregory Canyon Landfill, Delta project, and desalination plant, respectively.

2. CSDA

Mr. Kennedy noted RMWD would wait to participate in legislative training until February when it's held in San Diego.

3. LAFCO

Mr. Kennedy reported Judy Hanson has been appointed to the alternate seat.

4. San Luis Rey Watershed Council

Director Walker reported the Council met on June 27, 2016 and how they are in negotiations with an individual to prepare grant proposals as well as oversee a portion of an agricultural pilot program. He noted the Council reviewed the list of priorities again as well as how the agricultural seat still remains vacant.

5. Santa Margarita Watershed Council

There was no report given.

C. Meeting, Workshop, Committee, Seminar, Etc. Reports by Directors (AB1234)

There were no reports given.

D. Directors Comments

There were no comments.

***8. COMMITTEE REPORTS (Approved Minutes have been attached for reference only.)**

(*) - Asterisk indicates a report is attached.

DRAFT

DRAFT

DRAFT



- A. Budget and Finance Committee
 - 1. May 10, 2016 Minutes

Mr. Kennedy reported the committee reviewed the budget at their last meeting.

- B. Communications Committee
 - 1. May 2, 2016 Minutes

Mr. Kennedy reported the committee was in the process of reviewing communications plans. He mentioned the nomenclature “stakeholder” seemed to be favored as opposed to “ratepayer”; however, he wanted to solicit the Board for their input prior to making formal changes.

Director Walker expressed concern stakeholder could refer to anyone who has an interest in RMWD including outsiders. He suggested differentiating between RMWD stakeholders and outside stakeholders.

Mr. Kennedy said he would continue to work on this and report back to the Board at a later date.

- C. Engineering Committee
 - 1. May 4, 2016

Mrs. Kirkpatrick reported there were two recommendations from the Engineering Committee before the Board in regards to the Urban Water Management Plan and the Cross-Connection Control Policy, respectively. She noted the committee had a preliminary discussion on an introduction about capacity fees including the methodology which will be discussed further with the Budget and Finance Committee. She provided an update on the proposed development. She noted Caltrans has pretty much stopped working on the sewer portion of the Highway 76 project until they do the traffic switch.

BOARD ACTION ITEMS

***9. DISCUSSION AND POSSIBLE ACTION TO ADOPT RESOLUTION NO. 16-14 APPROVING FISCAL YEAR 2016-17 BUDGET**



Mrs. Martinez gave a presentation on the Fiscal Year 2016-2017 Operating and Capital Improvement Budget. She noted some revisions have been made since the Board reviewed the budget at their May 2016 Board meeting.

Mrs. Martinez thanked the Board, Budget and Finance Committee, and senior staff for their assistance with the budget process. Mr. Kennedy in turn thanked Mrs. Martinez for her hard work putting this new budget together.



Motion:

To approve the budget as submitted and Resolution No. 16-14.

Action: Approve, Moved by Director Walker, Seconded by Director Brazier.



Vote: Motion carried by unanimous vote (summary: Ayes = 4).

(*) - Asterisk indicates a report is attached.

DRAFT

DRAFT

DRAFT

Ayes: Director Sanford, Director Walker, Director Brazier, Director Bigley.

Absent: Director Stewart.

***10. DISCUSSION AND POSSIBLE ACTION ON APPROVAL OF RESOLUTION 16-13, ADOPTING THE DISTRICT'S DRAFT 2015 URBAN WATER MANAGEMENT PLAN**



Mrs. Kirkpatrick reported RMWD has not received any comments on the Urban Water Management Plan since the public hearing conducted at the last Board meeting; therefore, this item was before the Board to consider adoption of the plan.

Mr. Kennedy added SDCWA used a great deal of this data for forecasting RMWD's adequate supplies.



Motion:

Approve Resolution No. 16-13.

Action: Approve, Moved by Director Brazier, Seconded by Director Walker.



Vote: Motion carried by unanimous vote (summary: Ayes = 4).

Ayes: Director Sanford, Director Walker, Director Brazier, Director Bigley.

Absent: Director Stewart.

***11. DROUGHT ORDINANCE UPDATE**



Mr. Kennedy explained the State Board has changed its ruling and now allows RMWD to conduct a process that founded a 0% reduction requirement. He noted the State did have a number of end use requirements that are mandatory which he reviewed. He talked about the main changes to the ordinance which was to move the new mandatory requirements into the Level 1 Drought Watch without specific conservation requirements. He pointed out the Board will be considering a resolution to move RMWD into Drought Level 1 after this ordinance update item has been discussed.



Motion:

To accept the updated drought ordinance.

Action: Approve, Moved by Director Bigley, Seconded by Director Brazier.



Vote: Motion carried by unanimous vote (summary: Ayes = 4).

Ayes: Director Sanford, Director Walker, Director Brazier, Director Bigley.

Absent: Director Stewart.

***12. DISCUSSION AND POSSIBLE ACTION TO APPROVE RESOLUTION NO. 16-16 REDUCING THE DROUGHT LEVEL FROM LEVEL 2 TO LEVEL 1 IN ACCORDANCE WITH RMWD DROUGHT ORDINANCE NO. 16-10**

(*) - Asterisk indicates a report is attached.

DRAFT

DRAFT

DRAFT



Mr. Kennedy pointed out in the Ordinance it states the General Manager has the authority to change the drought level; however, he wanted to bring it to the Board for consideration.



Motion:

For the approval of Resolution No. 16-16.

Action: Approve, Moved by Director Brazier, Seconded by Director Walker.



Vote: Motion carried by unanimous vote (summary: Ayes = 4).

Ayes: Director Sanford, Director Walker, Director Brazier, Director Bigley.

Absent: Director Stewart.

***13. DISCUSSION AND POSSIBLE ACTION TO APPROVE ORDINANCE NO. 16-11 AMENDING AND UPDATING ADMINISTRATIVE CODE SECTION 8.20 – CROSS-CONNECTION CONTROL**



Mr. Kennedy noted the main aspects of the updates were related to wordsmithing as well as to remove the requirements for backflow devices to be installed at every home.

Legal Counsel pointed out prior to the meeting “8 fee” should be “8 feet” in Section 8.20.

Director Walker referenced Page 380 as he inquired as to whether the Department of Environmental Health can be included as an agency of authority. Legal Counsel suggested adding “other relevant authority having jurisdiction” to this section.

Motion:



To adopt Ordinance No. 16-11 with the amendments.

Action: Approve, Moved by Director Brazier, Seconded by Director Walker.



Vote: Motion carried by unanimous roll call vote (summary: Ayes = 4).

Ayes: Director Sanford, Director Walker, Director Brazier, Director Bigley.

Absent: Director Stewart.

(*) - Asterisk indicates a report is attached.

DRAFT

DRAFT

DRAFT

***14. DISCUSSION AND POSSIBLE ACTION REGARDING CALIFORNIA SPECIAL DISTRICTS ASSOCIATION (CSDA) 2016 BOARD ELECTIONS**



It was noted Jo MacKenzie has recommended John DeMonaco. Director Walker stated although the candidates are not known by the RMWD Board, he would be inclined to take Ms. MacKenzie's recommendation.



Motion:

To accept Mr. DeMonaco and the Board Member for CSDA.

Action: Approve, Moved by Director Brazier, Seconded by Director Walker.



Vote: Motion carried by unanimous vote (summary: Ayes = 4).

Ayes: Director Sanford, Director Walker, Director Brazier, Director Bigley.

Absent: Director Stewart.

15. DISCUSSION AND POSSIBLE ACTION TO APPOINT CYNTHIA GRAY AS AN ALTERNATE MEMBER TO THE COMMUNICATIONS COMMITTEE AND VANESSA MARTINEZ AS AN ALTERATE MEMBER TO THE BUDGET AND FINANCE COMMITTEE



Motion:

To support these two as alternates.

Action: Approve, Moved by Director Brazier, Seconded by Director Walker.



Vote: Motion carried by unanimous vote (summary: Ayes = 4).

Ayes: Director Sanford, Director Walker, Director Brazier, Director Bigley.

Absent: Director Stewart.

***16. DISCUSSION AND POSSIBLE ACTION TO APPROVE RESOLUTION NO. 16-15 — A RESOLUTION OF THE BOARD OF DIRECTORS OF RAINBOW MUNICIPAL WATER DISTRICT ESTABLISHING CLASSIFICATIONS AND MONTHLY PAY RANGES FOR DISTRICT EMPLOYEES EFFECTIVE JULY 1, 2016 THROUGH JUNE 30, 2017 AND THE GENERAL MANAGER'S SALARY EFFECTIVE AUGUST 29, 2015 THROUGH AUGUST 28, 2016**



Mr. Kennedy explained this resolution reflects the last 2% COLA approved under the current MOU. He also introduced Karleen Harp as the new RMWD Human Resources Manager. It was noted the General Manager performance evaluation will be on the August agenda as a Closed Session item and any action would be taken under an Open Session item.

(*) - Asterisk indicates a report is attached.

DRAFT

DRAFT

DRAFT



Motion:

To adopt Resolution No. 16-15 and direct human resources to post a copy on the RMWD website.



Action: Approve, Moved by Director Bigley, Seconded by Director Brazier.

Vote: Motion carried by unanimous vote (summary: Ayes = 4).

Ayes: Director Sanford, Director Walker, Director Brazier, Director Bigley.

Absent: Director Stewart.

***17. DISCUSSION AND POSSIBLE ACTION ON BOARD RELATED PROFESSIONAL SERVICES CONTRACTS**



Mr. Kennedy reported on the history of the auditors RMWD has utilized for several years. He also noted RMWD's records related to a contract with legal counsel needs to be updated.

Mr. Kennedy proposed utilizing Squar Milner for auditing services this year and then going out for bid after this year's audit is complete, putting out a Request for Proposal for legal services with an invite to Procopio, and continue utilizing Shepherd & Staats, Inc. for tax roll billing services.

President Sanford suggested with looking at proposals for both the auditor and legal services. Mr. Kennedy recommended waiting to solicit proposals for auditing services until after the auditing season passes; however, RFP's for legal services could be sent out at any time.

Motion:

Action: Accept staff recommendation:

- **Auditor – since we have only a short time before the next audit must commence, the recommendation is to proceed with Squar Milner for the FY15/16 audit and issue a RFP for auditing services in the fall of 2016.**
- **General Counsel – issue a RFP for General Counsel services. A draft RFP was presented to the Board in February 2016.**
- **Tax Roll Billing Services – since this work is a small expense and the current firm is well suited to the task, staff sees no benefit to RMWD in changing firms at this time. The cost of the RFP process would likely exceed the annual billing for this work with the addition of the timing for legal services.**

With the addition of the RFP for legal services being sent out immediately.

Moved by Director Walker, Seconded by Director Brazier.

(*) - Asterisk indicates a report is attached.

DRAFT

DRAFT

DRAFT



Vote: Motion carried by unanimous vote (summary: Ayes = 4).

Ayes: Director Sanford, Director Walker, Director Brazier, Director Bigley.

Absent: Director Stewart.

***18. DISCUSSION AND POSSIBLE ACTION TO APPROVE RESOLUTION NO. 16-17 ACCEPTING CALIFORNIA DEPARTMENT OF WATER RESOURCES PROPOSITION 50 WATER USE EFFICIENCY GRANT FUNDS AND DESIGNATE A REPRESENTATIVE AUTHORIZED TO EXECUTE THE CONTRACT AND SIGN REQUESTS FOR DISBURSEMENT**



Mr. Kennedy explained the new requirements implemented by the Governor. He mentioned Ken Weinberg was hired to assist with the grant processes. He noted RMWD needs to resolution stating the District accepts the money and that these funds will be utilized.

Motion:

To approve Resolution No. 16-17, Action: Approve, Moved by Director Brazier, Seconded by Director Walker.



Vote: Motion carried by unanimous vote (summary: Ayes = 4).

Ayes: Director Sanford, Director Walker, Director Brazier, Director Bigley.

Absent: Director Stewart

***19. RECEIVE AND FILE INFORMATION AND FINANCIAL ITEMS FOR MAY 2016**



- A. General Manager Comments**
 - 1. Meetings, Conferences and Seminar Calendar
- B. Communications**
 - 1. Ratepayer Letters
 - 2. Staff Training Reports
- C. Operations Comments**
 - 1. Operations Report
- D. Engineering Comments**
 - 1. Engineering Report
- E. Customer Service Comments**
 - 1. Customer Service Report
- F. Human Resource & Safety Comments**
 - 1. Human Resources Report
 - 2. Organizational Chart
- G. Finance Manager Comments**
 - 1. Credit Card Breakdown
 - 2. Check Register
 - 3. RMWD Sewer Equivalent Dwelling Units (EDU's) Status

Mr. Kennedy mentioned the demonstration he saw on ITRON and AMI during the recent AWWA conference. He also talked about space planning study being conducted for RMWD's facilities.

(*) - Asterisk indicates a report is attached.

DRAFT

DRAFT

DRAFT

Director Walker acknowledged the ratepayer letter included in the agenda packet noting it makes someone proud to be a part of an organization that puts customer service at the forefront demonstrating we care.

Mr. Kennedy noted the departmental reports have changed to reflect more vital information.



Motion:

To receive and file.

Action: Approve, Moved by Director Brazier, Seconded by Director Walker.



Vote: Motion carried by unanimous vote (summary: Ayes = 4).

Ayes: Director Sanford, Director Walker, Director Brazier, Director Bigley.

Absent: Director Stewart

20. LIST OF SUGGESTED AGENDA ITEMS FOR THE NEXT REGULAR BOARD MEETING



Ms. Washburn reported election packets will be mailed out by the Registrar of Voters the week of July 11th and will be available at the District for pick up. She noted completed packets must be filed on August 12th before 5:00 p.m.

21. ADJOURNMENT - To Tuesday, July 26, 2016 at 1:00 p.m.



The meeting was adjourned with a motion made by Director Brazier and seconded by Director Walker to a regular meeting on July 26, 2016 at 1:00 p.m.

The meeting was adjourned at 2:50 p.m.

Dennis Sanford, Board President

Dawn M. Washburn, Board Secretary

(*) - Asterisk indicates a report is attached.

**MINUTES OF THE BUDGET AND FINANCE COMMITTEE MEETING
OF THE RAINBOW MUNICIPAL WATER DISTRICT
JUNE 14, 2016**

1. **CALL TO ORDER:** The Budget & Finance Committee meeting of the Rainbow Municipal Water District was called to order by Chairperson Stitle on June 14, 2016 in the Board Room of the District Office at 3707 Old Highway 395, Fallbrook, CA 92028 at 1:02 p.m. Chairperson Stitle presiding.

2. **PLEDGE OF ALLEGIANCE**

3. **ROLL CALL:**

Present: Member Stitle, Member Ross, Member Hensley, Member Clyde, General

Absent: Member Moss

Also Present: General Manager Kennedy, Executive Assistant Washburn, Finance Manager Martinez, Engineering Manager Kirkpatrick, Administrative Analyst Gray

One members of the public was present.

4. **ADDITIONS/DELETIONS/AMENDMENTS TO THE AGENDA (Government Code §54954.2)**

There were none.

5. **PUBLIC COMMENT RELATING TO ITEMS NOT ON THE AGENDA (Limit 3 Minutes)**

There were no comments.

COMMITTEE ACTION ITEMS

6. **COMMITTEE MEMBER COMMENTS**

There were no comments.

*7. **APPROVAL OF MINUTES**

A. May 10, 2016

Mr. Stitle originally stated that he was marked absent although he was present at the May 10, 2016 meeting however it was confirmed later in the meeting that he was not present this meeting. No changes to the minutes were necessary.

Motion:

To accept the minutes.

Action: Approve, Moved by Member Hensley, Seconded by Member Clyde.

Vote: Motion carried by unanimous roll call vote (summary: Ayes = 4).

Ayes: Member Stitle, Member Ross, Member Hensley, Member Clyde.

8. DISCUSSION AND POSSIBLE ACTION TO APPROVE 2016/2017 FY BUDGET

Mr. Kennedy gave the discussion over to Mrs. Martinez who then introduced the Annual Operation and Capital Improvement Budget and began her presentation. Mr. Kennedy made a request to bring a discussion back next month in consideration of a small rate increase prior to the January 2017 projected increase allowing two small increases in lieu of one large one.

Mr. Kennedy stated the District will be taking a close look at the wastewater budget, examining cost involved and reviewing options such as contracting services in order to smooth out expenses. Mr. Kennedy added that there will be a shifting of funds and a possible reduction of sewer rates and added that research on relevant grant funding would continue. Open discussion among the committee members arose.

Mrs. Martinez pointed out that proposed rates are not included in the annual budget as there maybe changes due to possible capacity fees increasing. Mrs. Martinez explained that a rate increases would bring more profits and the rate structure presented in the budget documents is a worse-case scenario and very conservative.

Motion:

Recommendation to the Board to approve the budget.

Action: Approve, Moved by Member Hensley, Seconded by Member Ross.

Vote: Motion carried by unanimous roll call vote (summary: Ayes = 4).

Ayes: Member Stitle, Member Ross, Member Hensley, Member Clyde.

9. DISCUSSION REGARDING INTERNAL CONTROLS FOR VENDOR SETUP

Mr. Kennedy explained that this was to address Mr. Hensley's concerns regarding internal controls. Mrs. Martinez explained the process through finance for separating the task of accepting vendors in the system from staff scanning of vendor payments. She added that at the next meeting there will be a demonstration of financial practices in Springbrook our new financial software.

10. DISCUSSION REGARDING METER CLASSIFICATIONS

Mrs. Martinez asked for clarification on this topic. Mr. Stitle explained that this was regarding pairing suitable meter sizes with consumption. Mr. Kennedy stated there may be a change at the State level enacting a change to Proposition 218 allowing conservation pricing. Mr. Kennedy added that we can however change the current block rates adding that a capacity study will be useful in assessing the right size meter based on consumption. Mr. Kennedy indicated a Request for Information (RFI) with reference to asset evaluation has been completed however he has not seen the documentation as of yet.

Mr. Kennedy pointed out he will be meeting with SDG&E and Itron to discuss new innovative automated meter reading alternatives. Mr. Stitle asked if we have examined alternate energy sources for electricity. Mr. Kennedy asked if there was a particular program he was interested in and discussion ensued.

11. MONTHLY FINANCIAL REPORT

- A. Balance Sheet
- B. Financial Statement

General Ledger's balance sheets were provided for each fund and reviewed by the committee. Close examination of the documents continued. Mr. Stitle requested the column headers be included on each page of the document spreadsheets. Mr. Kennedy invited the committee to submit any additional change requests for these reports prior to the next meeting.

12. DISCUSSION AND POSSIBLE ACTION REGARDING COMMITTEE MEMBERSHIP

Mr. Kennedy recommended Mrs. Martinez as an alternate member for this committee and suggested the committee's recommendation be brought before the Board of Directors for action at their next meeting.

Motion:

To have Vanessa Martinez added to the Budget and Finance committee as an alternate.

Action: Moved by Member Stitle, Seconded by Member Ross.

Vote: Motion carried by unanimous roll call vote (summary: Ayes = 4).

Ayes: Member Stitle, Member Ross, Member Hensley, Member Clyde.

13. LIST OF SUGGESTED AGENDA ITEMS FOR THE NEXT SCHEDULED BUDGET AND FINANCE COMMITTEE MEETING

It was noted a Springbrook demonstration will be conducted at the next meeting. Also there will be items for the variance on sewer costs, strategic plan update, parliamentary procedure review and development update on the next meeting agenda.

14. ADJOURNMENT

Motion:

Action: Adjourn, Moved by Member Clyde, Seconded by Member Ross.

Vote: Motion carried by unanimous roll call vote (summary: Ayes = 4).

Ayes: Member Stitle, Member Ross, Member Hensley, Member Clyde.

Harry Stitle, Committee Chairperson

Dawn M. Washburn, Board Secretary

**MINUTES OF THE COMMUNICATIONS COMMITTEE MEETING
OF THE RAINBOW MUNICIPAL WATER DISTRICT
JUNE 6, 2016**

1. **CALL TO ORDER** – The Communications Committee Meeting of the Rainbow Municipal Water District on June 6, 2016 was called to order by Chairperson Daily at 3:33 p.m. in the Board Room of the District, 3707 Old Highway 395, Fallbrook, CA 92028. Chairperson Daily, presiding.

2. **PLEDGE OF ALLEGIANCE**

3. **ROLL CALL:**

Present: Member Daily, Member O'Leary, Member Brazier.

Absent: Member Kurnik, Member Kirby.

Also Present: Executive Assistant Washburn, Administrative Analyst Gray.

One member of the public was present.

4. **ADDITIONS/DELETIONS/AMENDMENTS TO THE AGENDA (Government Code §54954.2)**

There were no changes.

5. **PUBLIC COMMENT RELATING TO ITEMS NOT ON THE AGENDA**

There were no comments.

COMMITTEE ACTION ITEMS

*6. **APPROVAL OF MINUTES**

Motion:

Action: Approve, Moved by Member Brazier, Seconded by Member O'Leary.

Vote: Motion carried by unanimous vote (summary: Ayes = 3).

Ayes: Member Daily, Member O'Leary, Member Brazier.

7. **DISCUSSION AND POSSIBLE ACTION REGARDING COMMITTEE MEMBERSHIP**

It was determined Administrative Analyst Gray be added to the committee member to ensure a quorum is present at all meetings.

Motion:

Recommend to the Board that Cynthia Gray be added as an alternate member to the committee roster.

Action: Approve, Moved by Member Brazier, Seconded by Member O'Leary.

Vote: Motion carried by unanimous vote (summary: Ayes = 3).

Ayes: Member Daily, Member O'Leary, Member Brazier.

It was suggested RMWD continue to solicit for new members in the monthly newsletter.

8. DISCUSSION AND POSSIBLE ACTION REGARDING INCORPORATING NEW GRAPHICS INTO WEBSITE, NEWSLETTER, ETC.

Mrs. Gray pointed out the graphics in the newsletter have been dialed in. She recommended RMWD sending out a survey to get feedback from those who access the district website. Mr. Daily suggested a paper survey be included with the monthly bill. Mrs. Gray proposed bringing this matter back to the committee at the next Committee meeting for discussion.

Mr. O'Leary recommended expanding the website survey to a full customer service survey as part of the Strategic Plan. Mrs. Gray suggested bringing this back to the next committee meeting for consideration.

9. COMMUNICATIONS PLAN

Mrs. Gray noted the revisions made to the 2016 Newsletters Topics Suggestions as provided in the handout distributed. Discussion ensued regarding reporting media information relative to RMWD in the District newsletter.

Mrs. Gray thanked Mr. O'Leary for the write-up he provided on the Avocado Commission. It was noted, the write-up was quite long; however, portions of it could be utilized as "filler" in upcoming newsletter editions.

Discussion ensued regarding staff input in terms of being spotlighted in the newsletter.

Mr. O'Leary suggested the LAFCO event scheduled for July could be replaced with another topic.

10. REVIEW AND ANALYSIS OF RMWD RELATED MEDIA STORIES

Ms. Brazier reported one presidential candidate stated there was no drought in California.

11. COMMITTEE MEMBER COMMENTS

Mr. Daily mentioned he was monitoring the conjunctive use program involving FPUD and Camp Pendleton.

12. LIST OF SUGGESTED AGENDA ITEMS FOR THE NEXT SCHEDULED COMMUNICATIONS COMMITTEE MEETING

It was noted the object for a website/customer service survey, addition of a staff member to the committee, the newly approved Parliamentary procedures, a Strategic Plan quarterly update, and newsletter water-interest filler topics be on the next committee agenda for discussion.

Discussion ensued.

Mr. Hamilton suggested an article be written on the Groundwater Sustainability plan "Ag Alert" quoted as being due in mid 2017 and how this could involve RMWD.

13. ADJOURNMENT

Motion:

Action: Adjourn, Moved by Member Brazier, Seconded by Member O'Leary.

Vote: Motion carried by unanimous vote (summary: Ayes = 3).

Ayes: Member Daily, Member O'Leary, Member Brazier.

The meeting adjourned at 4:44 p.m.

Mike Daily, Committee Chairperson

Dawn M. Washburn, Board Secretary

**MINUTES OF THE ENGINEERING COMMITTEE MEETING
OF THE RAINBOW MUNICIPAL WATER DISTRICT
JUNE 1, 2016**

1. **CALL TO ORDER** – The Engineering Committee Meeting of the Rainbow Municipal Water District on June 1, 2016 was called to order by Chairperson Prince at 3:01p.m. in the Board Room of the District, 3707 Old Highway 395, Fallbrook, CA 92028. Chairperson Prince, presiding.

2. **PLEDGE OF ALLEGIANCE**

3. **ROLL CALL:**

Present: Member Prince, Member Stitle, Member Taufer, Member Brazier, Member Kirby, Member Ratican, Alternate Robertson and Alternate Marnett

Absent: Member Murray

Also Present: Engineering Manager Kirkpatrick, Associate Engineer Powers, Operations Manager Milner, Water Ops Superintendent Walker, Water Quality/CCC Tech Perriera, Engineering Tech Rubio

There were two members of the public present: Ms. Hollis and Mr. Patel (Willdan Consultants)

4. **ADDITIONS/DELETIONS/AMENDMENTS TO THE AGENDA (Government Code §54954.2)**

Mrs. Kirkpatrick requested to move Agenda Item #9 before Agenda Item #7.

5. **PUBLIC COMMENT RELATING TO ITEMS NOT ON THE AGENDA**

Mr. Marnett pointed out a possible liability issue near the Hutton Tank that is on District property. Mrs. Kirkpatrick would discuss the issue with Mr. Kennedy and respond back to Mr. Marnett.

COMMITTEE ACTION ITEMS

*6. **APPROVAL OF MINUTES**

A. May 4, 2016

Motion:

Accept the minutes as drafted.

Action: Approve, Moved by Member Brazier, Seconded by Member Kirby.

Vote: Motion carried by unanimous vote (summary: Ayes = 7).

Ayes: Member Prince, Member Stitle, Member Brazier, Member Taufer, Member Kirby, Member Ratican, Alternate Member Robertson

Discussion went to Item #9.

7. DISCUSSION AND POSSIBLE ACTION REGARDING URBAN WATER MANAGEMENT PLAN

Mrs. Kirkpatrick announced that the Urban Water Management Plan (UWMP) was presented at the public hearing last month and no comments were received. She asked the Committee for a recommendation to the Board to approve the UWMP at the next Board meeting.

Motion:

Recommend the Board Approve the UWMP.

Action: Approve, Moved by Alternate Robertson, Seconded by Member Stitle.

Vote: Motion carried by unanimous vote (summary: Ayes = 7).

Ayes: Member Prince, Member Stitle, Member Brazier, Member Taufer, Member Kirby, Member Ratican, Alternate Member Robertson.

***8. DISCUSSION AND POSSIBLE ACTION REGARDING ADMINISTRATIVE CODE SECTION 8.20 – CROSS-CONNECTION CONTROL**

Mrs. Kirkpatrick said a copy of the draft Cross Connection Control (CCC) Policy was provided with the agenda for review and comment. She asked the Committee to bring any comments to the next meeting to possibly move forward with a recommendation for Board approval.

Mr. Ratican suggested removing all references to regulations that were within the definitions. Discussion ensued.

Mrs. Kirkpatrick said about 10 years ago everyone was required to install a backflow, although currently only if there was a degree of hazard on the property would a backflow device be required. Mr. Walker said part of the intent of updating the policy was to allow customers to opt out of the program if there was no degree of hazard. Discussion ensued.

Based on the discussions and recommended revisions it was decided to go forward with a motion.

Motion:

Recommend to the Board to approve the Administrative Code Section 8.20 with revisions.

Action: Approve, Moved by Member Ratican, Seconded by Alternate Robertson.

Vote: Motion carried by unanimous vote (summary: Ayes = 7).

Ayes: Member Prince, Member Stitle, Member Taufer, Member Brazier, Member Kirby, Member Ratican, Alternate Robertson.

9. DISCUSSION REGARDING METHODOLOGY FOR CAPACITY FEES

Mrs. Kirkpatrick introduced Ms. Hollis and Mr. Patel Consultants from Willdan Financial Services contracted to perform an asset valuation study and to review alternative capacity fee methodologies. Ms. Hollis pointed out there were two parts to the project a System Valuation Report and a Capacity Fee Analysis Report. She provided a brief presentation regarding the project overview as follows:

Project Scope:

- Project Management
- Data and Information Collection and Review
- Develop Alternative Capacity Fee Methodologies
- System Market Analysis
- Determine Draft Capacity Fees for Water and Wastewater
- Meeting with Engineering Committee and BIA
- Prepare Draft and Final Study Reports and Board Presentation

Project Status:

- Data Collection and Review - Data request was sent and data was received.
- Site Inspection - Completed on the week of May 16, 2016.
- Capacity Fee Methodology Discussion - Completed on June 1, 2016.
- Draft System Valuation Report - Early July 2016.
- Draft Capacity Fee Analysis Report - Late July 2016.
- Final System Valuation Report and Capacity Fee Analysis - Presentations in August / September 2016. Finalize the reports.

Capacity Fee Overview:

Capacity fees are one time charges paid by new development. They finance construction to build facilities to serve new development. The philosophy being that growth pays for growth.

Capacity fees are used as follows:

- Utilities are required to make large investments in capacity related facilities in advance of new development.
- Customers connect to system over many years.
- Given the timing of improvements and the customer connection projects are often funded with debt.
- Capacity fees are used to fund the major “backbone” system.

Approaches to Developing Capacity Fees:

- Buy-in or Excess Capacity - Approach based on the value of existing system capacity.
- Incremental Cost - Approach based on value to expand existing system capacity during a 5 to 20 year period.
- Combined or hybrid approach blends value of existing and proposed system.

Key Steps in Capacity Fee Analysis:

- Determine the system planning criteria.

- Determine the associated cost or value of system and available capacity for systems.
- Determine new customer demands for each functional area of the system.
- Calculation of the capacity fee components.
- Determine any credits.

RMWD Capacity Fee:

- Combined or hybrid approach.
- Existing system: Develop value of system by each component in addition to developing overall and remaining system capacity by component.
- Proposed improvements and upgrades – new water supply component.

Mr. Stitle asked at what point would the District not issue water availability. Mrs. Kirkpatrick said she does not foresee reaching that point based on the District's Urban Water Management Plan and the Water Master Plan current and future water supplies are enough to support new development and annexation demands until 2030. Discussion ensued.

Discussion returned to Item #7.

10. LIST OF SUGGESTED AGENDA ITEMS FOR THE NEXT SCHEDULED ENGINEERING COMMITTEE MEETING

Mrs. Kirkpatrick suggested the parliamentary procedures for discussion and the Wastewater Reclamation Plant PDR for the next committee meeting.

11. ADJOURNMENT

Motion:

Adjourn the Engineering Committee Meeting.

Action: Approve, Member Brazier, Seconded by Member Stitle.

Vote: Motion carried by unanimous vote (summary: Ayes = 7).

Ayes: Member Prince, Member Stitle, Member Taufer, Member Brazier, Member Kirby, Member Ratican, Alternate Robertson.

Timothy Prince, Committee Chairperson

Dawn M. Washburn, Board Secretary



BOARD ACTION

BOARD OF DIRECTORS

July 26, 2016

SUBJECT

DISCUSSION AND POSSIBLE ACTION ON ADOPTION OF 2016 RMWD DOMESTIC WATER, RECYCLED WATER AND SANITARY SEWER FACILITIES CONSTRUCTION STANDARDS MANUAL

BACKGROUND

The District utilizes a Standards Manual containing general guidelines, design standards, standard specifications, standard drawings and a list of approved materials. The last Standards Manual update took place in 2011.

The Standards Manual is used by District staff, designers and contractors to design and install improvements for the District. The Standards Manual is an evolving document and is updated from time to time for improvements and to meet industry standards. These specifications establish standards of work, materials and construction procedures for improvements to District facilities.

DESCRIPTION

Over a five year period the Standards Manual has been revised by Operations and Engineering. Staff has conducted several meetings to go over the Standards Manual and recommend changes. Revisions have been made to the Standards from lesson learned, field experience, new and improved materials available and updates from the industry. Recycled water notes have been included in this update so developers may install a recycled water system where there will be recycled water demand. The draft manual was presented to and reviewed by the Engineering Committee. The Engineering Committee voted unanimously to recommend adoption by the District Board.

An up-to-date Standards Manual is an invaluable tool for plan checkers, inspectors, operators and the engineers to ensure consistent construction and design quality for projects within the District. There has been an increase in development activity and an up-to-date Standards Manual ensures that improvements meet District requirements.

A copy of the District's Standards Manual is available at the District's main office. If any member of the public wishes to purchase a manual, the cost will be \$65. Electronic copies will be available for download on the District's web site at no cost.

POLICY/STRATEGIC PLAN KEY FOCUS AREA

RMWD Domestic Water, Recycled Water and Sanitary Sewer Facilities Construction Standards Manual

BOARD OPTIONS/FISCAL IMPACTS

No fiscal impacts.

1. Adopt the 2016 RMWD Domestic Water, Recycled Water and Sanitary Sewer Facilities Construction Standards Manual
2. Recommend revisions to the Standards Manual and approve.

3. Do not approve the 2016 RMWD Standards and continue use of the 2011 Standards.

STAFF RECOMMENDATION

Staff recommends Option 1.



Michael Powers
Associate Engineer

July 26, 2016



DOMESTIC WATER, RECYCLED WATER AND SANITARY SEWER FACILITIES CONSTRUCTION STANDARDS MANUAL

JULY 2016

SEAL:



APPROVED:

SHERRY KIRKPATRICK
ENGINEERING MANAGER

TOM KENNEDY
GENERAL MANAGER



**RAINBOW MUNICIPAL WATER DISTRICT
DOMESTIC WATER, RECYCLED WATER AND SANITARY SEWER
FACILITIES CONSTRUCTION STANDARDS MANUAL**

TABLE OF CONTENTS

SECTION 1	GENERAL CONDITIONS
1.01	General
1.02	Reference Specifications
1.03	Definition of Terms
1.04	Abbreviations
1.05	Inspection
1.06	Defective Work
1.07	Temporary Suspension of Work
1.08	Errors or Discrepancies Noted by Contractor
1.09	Requests for Information
1.10	Plan and Profile Requirements
1.11	Submittals
1.12	Processing of Private Contracts
1.13	Compliance with Laws and Regulations
1.14	Contractor's Responsibility
1.15	Materials and Workmanship
1.16	Project Cleanup
1.17	Guarantee
1.18	Reference to Publications
1.19	Fees
1.20	Easements
1.21	General Notes and Requirements
1.22	Water Notes and Requirements
1.23	Sewer Notes and Requirements
1.24	Recycled Water Notes and Requirements

SECTION 2	DESIGN REQUIREMENTS
------------------	----------------------------

2.01	General Water and Sewer Requirements
2.02	Water Requirements
2.03	Sewer Requirements

**RAINBOW MUNICIPAL WATER DISTRICT
DOMESTIC WATER, RECYCLED WATER AND SANITARY SEWER
FACILITIES CONSTRUCTION STANDARDS MANUAL**

SECTION 3 TECHNICAL SPECIFICATIONS

Division 1 General Requirements (Not Used)

Division 2 Site Work

02223 Trenching, Backfilling and Compacting

Division 3 Concrete

03250 Concrete Anchors
03300 Cast-in-Place Concrete
03461 Precast Concrete Manholes

Division 4 Masonry (Not Used)

Division 5 Metals

05500 Miscellaneous Metals

Division 6 Wood and Plastics (Not Used)

Division 7 Thermal and Moisture Protection (Not Used)

Division 8 Doors and Windows (Not Used)

Division 9 Finishes

09900 Painting and Coating
09954 Polyethylene Sheet or Tube Encasement
09961 Fusion-Bonded Epoxy Lining and Coating

Division 10 Specialties (Not Used)

Division 11 Equipment (Not Used)

Division 12 Furnishings (Not Used)

Division 13 Special Construction

13110 Corrosion Control for Buried Piping
13200 Factory-Built Pressure Reducing Station
13250 Factory-Built Meter Station

Division 14 Conveying Systems (Not Used)

Division 15 Mechanical

15041 Disinfection of Pipe and Water Storage Facilities
15043 Sewer Leakage and Infiltration Testing
15044 Hydrostatic Testing of Pressure Pipelines

**RAINBOW MUNICIPAL WATER DISTRICT
DOMESTIC WATER, RECYCLED WATER AND SANITARY SEWER
FACILITIES CONSTRUCTION STANDARDS MANUAL**

- 15056 Ductile-Iron Pipe and Fittings
- 15057 Copper Tubing, Brass and Bronze Pipe Fittings
- 15062 Polyvinyl Chloride (PVC) Gravity Sewer Pipe and Fittings
- 15064 Polyvinyl Chloride (PVC) Pressure Pipe (C900)
- 15070 Polyvinyl Chloride (PVC) Distribution Pipe (C905)
- 15076 Cement Mortar Lined and Coated Steel Pipe
- 15100 Valves
- 15101 Resilient Seated Gate Valves
- 15109 Fire Hydrant Assemblies
- 15112 Backflow Prevention Assemblies
- 15125 Open Trench Pipe Casing
- 15130 Jacked Pipe Casing
- 15150 Water Meters

SECTION 4

DRAWINGS

W

POTABLE WATER FACILITIES

- W-1 Typical 1" to 2" Water Service Installation
- W-1A Reduced Water Service Installation
- W-2 3" Water Service
- W-2A 4" to 6" Water Service
- W-3 Standard Pipe Zone and Trench Backfill
- W-4 Concrete Thrust Blocks
- W-5 Service Outlet Saddle
- W-6 2" Blow Off Assembly
- W-7 4" Blow Off Assembly (Pressure Less Than 250 psi)
- W-8 4" Blow Off Assembly (Pressure Greater Than 250 psi)
- W-9 6" Fire Hydrant Assembly (Pressure Less Than 250 psi)
- W-10 6" Fire Hydrant Assembly (Pressure Greater Than 250 psi)
- W-11 1" and 2" Automatic Air Release and Vacuum Relief Valve
- W-12 4" and 6" Automatic Air Release and Vacuum Relief Valve
- W-13 Standard Guard Post Installation
- W-14 Standard Restraint, Tee, Dead End, Bend for PVC C-900 & C-905
- W-15 Standard Cutoff Wall
- W-16 Appurtenance Wall
- W-17 Standard Cul-de-Sac Water Laterals
- W-18 Standard Pressure Regulating Station
- W-19 Valve Well Frame
- W-20 Valve Well Cover
- W-21 Trench Resurfacing Types A & B
- W-22A 4" and Larger Fire Service Installation
- W-22B 4" and Larger Fire Service Installation (Notes and Description)
- W-23A & B Drawings Deleted

**RAINBOW MUNICIPAL WATER DISTRICT
DOMESTIC WATER, RECYCLED WATER AND SANITARY SEWER
FACILITIES CONSTRUCTION STANDARDS MANUAL**

W-24 Water Sampling Station

W-25 Tracer Wire

CP CATHODIC PROTECTION

CP-1 2 - Wire Test Station (Paved Street)

CP-2 2 - Wire Test Station (Unpaved Area)

CP-3 2 or 4 - Wire Test Station

CP-4 At Grade Test Box

CP-5 Buried Insulating Flange

CP-6 Buried Insulating Flange At - Grade Test Station

CP-7 4 - Wire Casing Test Station

CP-8 Above - Grade Insulating Flange

CP-9 Mechanical Joint Bond

CP-10 Cement Mortar Lined & Coated (CML&C) Steel Pipe Joint Bond (Wire Jumper)

CP-11 Ductile-Iron Pipe (DIP) Joint Bonding and Test Lead Connections

CP-12 Single Anode Installation

CP-13 Single Anode Test Station Wiring

CP-14 Prepackaged Magnesium Anode

CP-15 Exothermic Weld

CP-16 New Installation of Sacrificial Anodes for Copper Tubing

CP-17 Retrofit Installation of Sacrificial Anodes for Copper Tubing

S SANITARY SEWER FACILITIES

S-1 Standard Pipe Zone and Trench Backfill

S-2 Concrete Encasement

S-3 Pipeline Separation Requirements

S-4 Standard Precast Concrete Manhole (4' dia.)

S-5 Standard Precast Concrete Manhole (5' dia.)

S-6 Standard Precast Concrete Inside Drop Manhole

S-7 36" Manhole Frame and Two Concentric Covers

S-8 New Installation PVC Sewer Lateral

S-9 Deep Cut Sewer Lateral

S-10 Standard Cutoff Wall for Non Paved Area

S-11 Standard Cul-De-Sac Sewer Laterals

S-12 Sewer Manhole Adjustment

S-13 Sewer Manhole Adjustment Notes

S-14 Trench Resurfacing Types A & B

**RAINBOW MUNICIPAL WATER DISTRICT
DOMESTIC WATER, RECYCLED WATER AND SANITARY SEWER
FACILITIES CONSTRUCTION STANDARDS MANUAL**

SECTION 5 APPROVED MATERIALS LIST

SECTION 6 STANDARD FORMS

- 6.01 Encroachment Application**
- 6.02 Encroachment Permit**
- 6.03 Grant Right of Way (Exclusive Only)**
- 6.04 Grant Right of Way (Non-Exclusive)**
- 6.05 Easement Quitclaim Deed**
- 6.06 Notice of Completion**
- 6.07 RMWD Signature Block**

**GENERAL
CONDITIONS**

SECTION 1

GENERAL CONDITIONS

1.01 GENERAL

These specifications establish standards for work, materials, and construction procedures for improvements to the water, recycled water and sanitary sewer systems of the Rainbow Municipal Water District (RMWD). These specifications are intended to establish general requirements for all work performed within the District. These Standards are not intended to provide specific requirements for any particular project. Therefore, each project shall also be designed under the specific direction of a civil engineer licensed in California.

1.02 REFERENCE SPECIFICATIONS

Wherever reference is made within these documents to certain standard specifications, the reference shall be construed to mean the latest standards, with all subsequent amendments, changes, or additions as thereafter adopted and published that are in effect at the date of approval by the District of the plans and specifications prepared by a private engineer.

APWA	American Public Works Association
ASTM	American Society for Testing Materials
AWWA	American Water Works Association
ASME	American Society of Mechanical Engineers
ANSI	American National Standard Institute
ACI	American Concrete Institute
SSPWC or "Green Book"	Standard Specifications for Public Works Construction
SDRSD	San Diego Regional Standard Drawings

1.03 DEFINITION OF TERMS

A. Whenever in these specifications or other contract documents where these specifications govern, the following terms are used, they shall be defined as follows:

1. Applicant: Shall mean any property owner who makes application for District service or enters into an agreement with the District.
2. Approved, directed, satisfactory, proper, acceptable, required, necessary, and/or equal: shall be defined as considered approved, directed, satisfactory, proper, acceptable, required, necessary, or equal in the opinion of the District.
3. Appurtenances: Valves, stops, bends, elbows, reducers, services, backflow preventers, bushings, plugs, caps, blocks, jackets, wyes, cleanouts, manholes, frames and covers, lateral markers and all other fittings, nuts, bolts, washers, gaskets or other work required to make a complete installation.
4. Board of Directors: The Board of Directors of RMWD.

5. **Building Lateral:** Shall refer to the extension from the building drain to the service lateral at the property line, or other place of disposal.
6. **Collection Line:** Shall mean the District's sewer pipeline to which the service laterals are connected.
7. **Contract:** The Contract between the Applicant (property owner) and his Contractor.
8. **Contractor:** The person or entities entering into a contract with the Applicant for performance of the work or improvements pursuant to these specifications. The contractor shall at all times be represented on-site in person or by a duly designated agent or superintendent. Instructions or information given by the Engineer to the Contractor's superintendent or agent on the work shall be considered as having been given to the Contractor.
9. **Days:** Unless otherwise specified, days shall mean calendar days.
10. **Distribution Main:** Shall mean the District's water pipeline to which the water service laterals are connected.
11. **District:** The Rainbow Municipal Water District.
12. **Elevation:** Elevations referred to herein are to be based upon the U.S.C. & G.S. datum.
13. **Engineer:** A registered civil engineer appointed by the District acting either directly or through his/her properly authorized agent, engineers, assistants, inspectors and superintendents, unless otherwise qualified.
14. **Engineering Manager:** Engineering Manager of RMWD or an Authorized Representative.
15. **General Manager:** General Manager of the RMWD.
16. **Inspector:** A designated representative of the District acting through the Engineering Manager.
17. **Owner (Developer):** Any person or entity who agrees to construct and install facilities which after acceptance will become part of the District's system and who must select and employ a licensed Class A, or approved C-34 or C-42 contractor, to perform the work.
18. **Plans:** The official scale and full size approved detail drawings, or exact reproductions thereof, which show location, character, dimensions, elevations, and details of the work to be done.
19. **Private Engineer:** A California registered civil engineer employed by the Applicant.
20. **RMWD:** Rainbow Municipal Water District.
21. **RMWD Standards Manual:** The applicable design criteria published in the "Domestic Water, Recycled Water and Sanitary Sewer Facilities Construction Standards Manual." This includes water system and sewer system requirements for subdivisions and other extensions within the boundaries of the RMWDs as adopted by the Board of Directors including all amendments thereto.
22. **Service Lateral, Sewer:** Shall mean the sewer pipeline from a building sewer at the property line to a collection line within public right-of-way or easement.
23. **Service Lateral, Water:** Shall mean the water line from the water distribution main within the public right-of-way or easement to the water meter.

24. **Standard Drawings:** The standard drawings, a part of the "Domestic Water, Recycled Water and Sanitary Sewer Facilities Construction Standards Manual," unless otherwise modified.
25. **Standard Specifications:** The standard specifications, a part of the "Domestic Water, Recycled Water and Sanitary Sewer Facilities Construction Standards Manual," unless otherwise modified.
26. **Subcontractor:** Any person or entity who has a contract with the Contractor to perform any of the work at the site. Subcontractor also means any person who has a contract with a subcontractor to perform any of the work at the site. All subcontractors must be approved by the District.
27. **Transmission Main:** Shall mean a large diameter main water pipeline to which distribution mains are connected and that serves the primary purpose of transporting water from one area of the District to another.
28. **Trunk Line:** Shall mean a main line sewer pipeline to which collection lines are connected and that serves the primary purpose of transporting sewage from collection lines to the treatment plant.
29. **Utility:** Public or private facilities for the transportation of fluids, gases, power, signals, or communications.
30. **Work:** Labor, materials, equipment, transportation, or other facilities and safety measures necessary to complete the improvement proposed under the Contract or Permit.

1.04 ABBREVIATIONS

The abbreviations used in the plans and specifications are abbreviations of the meanings of which are established by general usage throughout the industry and those defined below:

ABAN	Abandoned	ASCE	American Society of Civil Engineers
AC	Acre/Asphalt Concrete/Alternating Current	ASPH	Asphalt
ACP	Asbestos-Cement Pipe	ASSY	Assembly
AGG	Aggregate	ASTM	American Society for Testing & Materials
ANSI	American National Standards Institute	AWWA	American Water Works Association
APWA	American Public Works Association		

BC	Beginning of Curve	BVC	Begin Vertical Curve
-----------	--------------------	------------	----------------------

CMLC	Cement Mortar Lined & Coated	CONC	Concrete
-------------	------------------------------	-------------	----------

DIA	Diameter	DIPRA	Ductile-Iron Pipe Research Association
DIP	Ductile-Iron Pipe		

EC	End of Curve	EPA	Environmental Protection Agency (Federal)
EL	Elevation/Each Layer	ESMT	Easement
ELEC	Electric	EST	Estimate or Estimated
EP	Edge of Pavement	EVC	End Vertical Curve

FG	Finished Grade	FPS	Feet Per Second
FH	Fire Hydrant	FS	Finished Surface/Floor Sink/Federal Specifications
FIP	Female Iron Pipe Thread	FT	Feet
FLG	Flange		

G	Gas	GALV	Galvanized
GAL	Gallon	GB	Grade Break

HDPE	High-Density Polyethylene Pipe	HWL	High Water Level
HGL	Hydraulic Grade Line	HWY	Highway
HORIZ	Horizontal		

ID	Inside Diameter	I/O	Inlet/Outlet
IE	Invert Elevation	IPT	Iron Pipe Thread
IN	Inches	IRR	Irrigation
INV	Invert		

LF	Linear Foot	LWL	Low Water Level
LP	Light Pole		

MATL	Material	MIN	Minimum
MAX	Maximum	MIP	Male Iron Pipe Thread
MECH	Mechanical	MISC	Miscellaneous
MGD	Million Gallons Per Day	MJ	Mechanical Joint
MH	Manhole	MOV	Motor Operated Valve

NA	Not Applicable	NE	Northeast
NACE	National Association of Corrosion Engineers	NTS	Not to Scale
NBS	National Bureau of Standards	NW	Northwest
NC	Normally Closed	NWL	Normal Water Level

OAE	Or Approved Equal	OD	Outside Diameter
OC	On Center	OSHA	Occupational Safety and Health Administration, U.S. Department of Labor, as defined in the General Conditions

PE	Plain End	PV	Plug Valve
PI	Point of Intersection	PVC	Polyvinyl Chloride
PO	Push-On	PVI	Point of Vertical Intersect
POB	Point of Beginning	PVMT	Pavement
PSI	Pounds Per Square Inch		

QTY	Quantity		
------------	----------	--	--

RJ	Restrained Joint	RWGV	Resilient Wedge Gate Valve
R/W	Right-Of-Way		

S	South	SS	Stainless Steel
SCADA	Supervisory Control and Data Acquisition	ST	Street
SCH	Schedule	STA	Station
SE	Southeast	STD	Standard
SPEC	Specification	SW	Southwest
SSPW	Standard Specifications for Public Works Construction		

TC	Top of Curb	TYP	Typical
TEMP	Temporary		

UTIL	Utilities		
-------------	-----------	--	--

VC	Vertical Curve	VPI	Vertical Point of Intersection
VERT	Vertical		

W	West	WT	Weight
WM	Water Meter	WTR	Water

1.05 INSPECTION

The Engineering Manager will provide inspection for all work which is to be dedicated to the District upon completion. All materials and work shall be performed only in the presence of the Engineering Manager and any work done in the absence of said Engineering Manager shall be subject to rejection. The Contractor shall notify the Engineering Manager five (5) working days prior to starting and two (2) working days during construction, in order that inspection services may be provided. No inspection shall be available on weekends, District holidays or before 7:00 a.m. or after 3:30 p.m.

1.06 DEFECTIVE WORK

The inspection of the work shall not relieve the Applicant of any of his obligations to fulfill his agreement or permit with the District. Defective work shall be made good, and unsuitable materials may be rejected, notwithstanding that such work and materials may have been previously inspected by the Engineering Manager and accepted. If the work, or any part thereof, shall be found defective at any time before the final acceptance of the whole work, the Applicant or his Contractor shall correct such defect in a manner satisfactory to the Engineering Manager. All costs for retesting and re-inspection which are necessitated by defective materials and/or workmanship shall be at the sole expense of the Applicant.

1.07 TEMPORARY SUSPENSION OF WORK

The Engineering Manager shall have the authority to suspend the work wholly or in part for such time as he/she may deem necessary due to the failure on the part of the Contractor to carry out orders given, or to perform any provisions of the Contract. The Contractor shall immediately comply with the written order of the Engineering Manager to suspend the work wholly or in part. The work shall be resumed when methods or defective work has been corrected as ordered or approved in writing by the Engineering Manager.

In the event that a suspension of work is ordered as provided above, such suspension of work shall not relieve the Contractor of his responsibility to complete the work within the time limit set

forth in the Agreement for Construction of Water and/or Sewer System, and shall not be considered cause for extension of the time for completion.

1.08 ERRORS OR DISCREPANCIES NOTED BY CONTRACTOR

If the Contractor, either before commencing work or in the course of the work, finds any discrepancy between these Specifications and Drawings, or between either of them and the physical conditions at the site of the work, or finds any error or omission in any of the drawings or in any survey, he shall promptly notify the Engineering Manager in writing of such discrepancy, error or omission.

1.09 REQUESTS FOR INFORMATION

Inquiries for existing RMWD facilities shall be made in writing or in person at the District offices.

1.10 PLAN AND PROFILE REQUIREMENTS

A. General.

1. All plans approved by RMWD shall have a two (2) year period in which to begin construction beginning from the date of the Engineering Manager's approval. At the end of the two year period the plans will be considered as expired. The plans must be resubmitted with the entire plan check fee and other submittal requirements before being considered for plan check. If RMWD standards are revised within the two year period, the project plans must be revised and conform to new standards.
2. All proposed work prepared by a Private Engineer shall be submitted to the Engineering Manager for approval on sheets which conform to the requirements of this section. All sheets shall be signed, sealed and dated by the Private Engineer responsible for the designs.
3. The overall size of each sheet shall be 24-inches high by 36-inches wide. Each sheet shall have a 2-inch wide margin on the left-hand border and ½-inch wide margins on the top, bottom, and right-hand borders.
4. Digital files with the District's standard title block, border, revision box and General Notes are available at the District Office. The Engineering Manager's approval is required for any deviation from this format.
5. Name and registration number of the Private Engineer responsible for the preparation of the project or the name of the firm and the name and registration number of the private engineer under whose direction the plans were prepared. Space shall also be provided for the Private Engineer's signature, seal, date of expiration of said registration and seal.
6. The Revision box shall include the letter of the revision, date made, description of change and space for the initials of both the person making the change and for District approval. Revisions shall be marked with small triangles containing the letter of the revision and placed near the location of such change.
7. Each project shall contain a legend and list of abbreviations for use in defining the symbols and abbreviations used on the sheets. All symbols and abbreviations used must be defined on the Title sheet or Note sheet.
8. Waterline and Sewerline data table is required for each project. Include a column for Delta, bearing, radius, length, description and station.
9. A lateral table is required for each project:

- a. For water service include a column for lot number, design station, As-Built station, size of service, static pressure at service, and length of service.
- b. For sewer laterals provide lot number, design station, As-Built station, length of lateral, depth at property line, slope, hike-up and a column to indicate the use of a backflow preventer.

10. The following information shall be located on the Title Sheet:

- a. The name, address and phone number of the Private Engineer responsible for the preparation of the project.
- b. A location map at a scale of 1-inch = 2,000-feet showing and labeling the boundary of the project in relation to major streets or interstate, district boundaries, adjacent developments and other pertinent features. The location map shall have a north arrow oriented towards the top of the sheet.
- c. A vicinity map at a scale of 1-inch = 200-feet (minimum) to show the entire project without match lines. The vicinity map shall contain lot boundaries, street right-of-way lines and names, a general layout of the sewer and/or water lines with size and material, location of manholes, main line valves, fire hydrants, blow-offs, air and vacuum valves and other major appurtenances, and other features, natural or artificial, necessary for a general understanding of the project. The vicinity map shall have a north arrow oriented towards the top of the sheet.
- d. A written description of benchmarks, including locations, elevations and vertical datum.
- e. An index to all drawings.
- f. Applicable approval blocks for County Road Department, County Fire Department and Department of Health Services.
- h. Manholes shall be sequentially numbered on the plans with numbers beginning at the lowest invert.

B. Plan Drawings. The Plan view of all drawings shall include the following:

- 1. Scale shall be a minimum of 1-inch = 40-feet unless otherwise approved by the Engineering Manager.
- 2. All sewer and/or water facilities, street lines, lot lines, curb grades, storm drains, driveways and other utilities both existing and proposed and all other features necessary to give a complete understanding of the project.
- 3. Survey stationing of the centerline of all manholes, valves, or other structures relative to centerline stationing or right-of-way stationing and provide the pipe data for all bends, curves, or deflections.
- 4. Show the alignment with bearings and distances and width of all easements with recording information for facilities not within public rights-of-way.
- 5. The plan shall include a north arrow oriented generally upwards or to the left.
- 6. Match lines shall be used between the sheets separated portions of the plan. Each match line shall be cross-referenced to show the sheet location of the matching portion of plan whether it be on the same or different sheet.
- 7. Existing monumentation in existing streets shall be shown.

- C. Profile Drawings. Profile drawings shall normally be shown on the same sheet and directly above the corresponding plan view so that manholes, valves, air and vacuum valves and other appurtenances in both the plan and profile view are vertically aligned as nearly as possible. Profile drawings shall be drawn at the same horizontal scale as the plan view. The normal vertical scale shall be 1-inch = 4-feet. The vertical elevations shall be written on both the left and right sides of the profile. Where water and sewer lines cross or where they cross other facilities such as drainage structures, the profile shall show elevations of top and bottom of the lines at the crossings.

Profile drawings shall show and label the following information, as applicable:

1. Profile (at centerline of street or easement) of existing and proposed ground surface.
 2. Size, slope (to 4 significant figures), pressure rating, and material of pipeline.
 3. All deflection angles shall be shown in profile and labeled as Grade Break (G.B.). The angle shall be shown in degrees, minutes, seconds. When high deflection couplings are used they must be called out in profile at the location of the grade break.
 4. Survey stationing of street centerline between centerline of manholes or valves and actual distance between centerline of valves or outside of manhole to outside of manhole.
 5. Pipeline elevations to the nearest 0.01-foot of invert for sewer and to the nearest 0.01-foot of centerline for water. The invert of the pipeline shall be shown in profile and labeled as "invert grade".
 6. Rim elevation of manholes or other structures.
 7. Any existing or proposed pipeline, utility, or similar structure that crosses the waterline or parallels the line with less than 5-feet between the existing and proposed utilities.
 8. The location and limits (include station) of other features such as a steel casing, concrete encasement, extra strength pipe, special pipe bedding, etc.
 9. Depth of manhole from rim to flow line of lowest pipe invert.
 10. Elevations at the inlet and outlet of the manholes.
 11. Private sewer laterals must be shown in profile where they cross other utilities where it appears a potential conflict exists.
 12. Match lines shall be used between the sheets separated portions of the profile. Each match line shall be cross-referenced to show the sheet location of the matching portion of profile whether it be on the same or different sheet.
 13. Profile drawings shall be discontinued at match lines with survey stationing and cross-referencing corresponding to the match lines shown on the plan drawing.
- D. Standard Details. Where the Private Engineer intends to use any of the Standard Details without modification, these details need not be reproduced on the Construction Plans provided that specific reference is made to each detail. For example, a manhole detail would not be required provided that the callout for the manhole refers to RMWD Standard Drawing S-4. Where the Private Engineer intends to modify any of the Standard Details, these revised details shall be included in the Construction Drawings in their entirety for District approval.
- E. Special Details. Special Details are required for any tie-in to an existing waterline or as required by the Engineering Manager. Connection details must include all pipe and fitting materials, couplings, fittings and adapters necessary to construct the tie-in.

- F. As-Builts Plans. On completion of the project the Engineering Manager shall be given a complete set of full-size photo reproducible mylar sheets (ammonia mylar sheets are not allowed) that shall show, in complete detail, all elements of the project, as constructed, text must be legible. The words "As-Builts" shall be boldly stamped on each sheet in ½-inch high bold block letters. The As-Built drawings will be reviewed and must be signed off by the Engineering Manager prior to issuing a Notice of Completion. An electronic copy of the mylar sheets shall also be provided on a computer disk or CD. Each sheet of the drawing set shall be scanned and saved as a separate file as a TIFF image. Electronic copy of As-Built drawings must be compatible with AutoCAD version compatible with RMWD.
- G. Advertising. Plans shall be free of advertising, insignia, labels, emblems, seals, or other markings not relevant to the work. When approved and accepted by the Engineering Manager, such plans shall become the property of the RMWD.
- H. Responsibility. Approval of plans by RMWD will not relieve the Applicant, Owner or Engineer of any responsibility because of errors in the plans either of commission or omission. Such errors, when brought to the attention of the private engineer by the Engineering Manager, shall be promptly remedied as herein provided.
- I. Revisions. After mylars have been approved and filed, or after inspection fees have been paid, changes may be made to the plans upon approval of the Engineering Manager. In order to obtain such approval, the Private Engineer shall first submit two (2) sets of duplicate blueines of the original drawings upon one set of which the proposed change is shown. At the discretion of the Engineering Manager, construction of changes shall not be completed until revisions are approved.

1.11 SUBMITTALS

- A. Three (3) sets of the water and sewer facilities design drawings shall be submitted to the Engineering Manager for plan check. The drawings shall be accompanied by a complete description of all materials, structures, and mechanical equipment to be used on the project.
- B. One (1) set of street improvement plans. Approved street plans are required prior to District approval of water and/or sewer improvement plans.
- C. One (1) set of storm drain or drainage improvement plans. Approved storm drain or drainage improvement plans are required prior to District approval of water and/or sewer improvement plans.
- D. One (1) copy of the soils report
- E. One (1) set of grading plans. Approved grading plans are required prior to District approval of water and/or sewer improvement plans.
- F. One (1) set of irrigation plans.
- G. One (1) copy of the tentative tract or parcel map indicating phasing schedule, if applicable.
- H. One (1) copy of the final tract or parcel map.
- I. One (1) copy of Conditions of Approval.

- J. One (1) copy of the area study and design calculations for sizing of the water and sewer improvements.
- K. Letter of Fire Flow Requirements from the appropriate Fire Protection District. The requirements may be included in the Conditions of Approval.
- L. Wet stamped Private Engineers cost estimate for all public water and sewer facilities. This cost estimate shall be based on a copy of the San Diego County Subdivision Cost Guidelines.
- M. Calculations for length of restrained joint including all assumptions used.
- N. Legal description, plat and Grant of Easement form for all easements.
- O. Contractor submittals are required for all installations. Submit materials to the Engineering Manager for approval.

1.12 PROCESSING OF PRIVATE CONTRACTS

- A. Legal Description. A legal description and a plat of the property to be served by the proposed water main or sewer or the property through which the proposed water or sewer line will traverse must be filed with the District in the form of a Preliminary Title Report.
- B. Plan Check Application. The required plan checking fee shall be paid to the District and three (3) sets of blue line prints shall be submitted to the Engineering Manager for checking, signed and stamped by a registered civil engineer. Checking of the plans will commence by the Engineering Manager as soon as fees are paid and as soon as possible following receipt of the items to be submitted per Section 2 General Conditions.
- C. Items to be Submitted. Irrigation plans, street improvement plans, grading plans, and the latest tract maps shall be submitted along with the required prints. In addition, the Applicant shall submit a plan of the subdivision lots and streets prepared on mylar at a scale of 1-inch = 200-feet. Other items are listed under Section 1.11.
- D. Corrections. After the District has checked the proposed plans and if corrections are necessary, the plan will be directed back to the Private Engineer or Applicant. After the required changes and corrections are made, the plan shall be resubmitted to the Engineering Manager including two (2) sets of new blue line prints, the old check print and the original mylars. When all corrections or modifications to the plans are complete and all necessary supplemental data, including records, letters, maps, and payments, are on file in the District office, the plans will be approved. After mylars are signed, provide four (4) sets of approved drawings and the original mylars to the Engineering Manager.
- E. Excess Capacity. Upon the request of the Applicant and upon approval by the Engineering Manager, an agreement for potential reimbursement of the Applicant for excess capacity of facilities may be entered into in instances where the Engineering Manager requires the Applicant to build facilities larger than are necessary to serve his property at one (1) year of service.
- F. Other Permits. The Applicant, or his authorized representative, shall obtain the necessary permits or approvals relative to the construction work and, if required, a State Highways Utility Encroachment Permit and/or a City/County Encroachment Permit. Any approvals or permits from utility companies, i.e. SDG&E, shall also be obtained by the Contractor.

- G. Notification for Inspection Services. The Engineering Manager shall be notified a minimum of five (5) working days prior to the commencement of construction and two (2) copies of water and sewer cut sheets are to be furnished to the Engineering Manager before work is started.
- H. Easements. The Applicant shall convey to the Engineering Manager easements and scaled plats covering property in which water and/or sewer facilities are constructed in all instances when the facilities are not located in dedicated streets. All easement boundaries shall be staked prior to waterline construction. All easements where District Facilities are installed shall be dedicated to RMWD. Access to and across the easement shall be kept clear and free of obstruction.
- I. Final Inspection. When all construction work has been completed and inspected per Article 1.05 of this section, the Applicant shall notify the Engineering Manager that the work is ready for final inspection. The Engineering Manager shall thereupon inspect the finished work and either approve it or reject it pending fulfillment of unsatisfied requirements. If the work is approved on final inspection, the Applicant shall record a Notice of Completion in a form approved by the District. The notice of completion will only be issued after As-Builts and digital files are submitted and approved and all account balances are brought current.
- J. Quit Claim Deed of Facilities to the District. The Applicant shall sign and submit to the Engineering Manager three (3) copies of a Quit Claim Deed of facilities.
- K. Liens. The Applicant shall furnish to the Engineering Manager satisfactory proof (ordinarily in the form of a title company report) that no liens were filed against the project prior to the expiration of the lien report.
- L. Conclusion. Upon satisfaction of all the foregoing requirements, including performance of the terms and conditions of the agreement with the District, the District will accept and will thereafter own, operate, and maintain the facilities. The Contractor is responsible for faulty workmanship or materials for a period of one year after acceptance by the District (See Paragraph 1.06). A final letter will be sent to the Commissioner of Real Estate, upon the Applicant's request.

1.13 COMPLIANCE WITH LAWS AND REGULATIONS

- A. Compliance. The Applicant and the Contractor shall keep themselves informed of all laws, ordinances, and regulations in any manner affecting those employed on the work, or materials used in the work, or in any way affecting the conduct of the work, and of all orders and decrees of agencies having any jurisdiction or authority over the same. They shall at all times observe and comply with, and shall require all their agents, employees, contractors, and subcontractors to observe and comply with all such applicable laws, ordinances, regulations, orders, and decrees in effect or which may become effective before completion of the work.
- B. Taxes, Permits and Licenses. Unless otherwise explicitly provided in these specifications, all permits and licenses necessary from the City, County, State or Federal regulatory agencies for prosecution of the work shall be secured by the Applicant or his Contractor at no expense to the District, and he shall pay all taxes assessed against his equipment or property used in connection with the work. The Contractor shall be responsible for providing California Environmental Quality Act compliance and obtaining all permits necessary to

complete the work. All work in existing streets will additionally require the contractor to obtain an encroachment permit from the jurisdictional agency.

1.14 CONTRACTOR'S RESPONSIBILITY

- A. Excavation Permit. Before any work is commenced, the Contractor shall secure and pay for the excavation permit required by the California Division of Occupational Health and Safety and shall furnish the District with a copy thereof prior to commencing any excavation.
- B. When working in a paved street the contractor shall perform all street work in accordance with San Diego County Standards.
- C. Insurance. The contractor will be required to furnish the Engineering Manager proof of full compliance with all insurance requirements.
- D. Protection of the Work. The Contractor shall take all necessary measures to protect the work and prevent accidents during the construction. He shall provide and maintain sufficient night lights, barricades, guards, temporary sidewalks, temporary bridges, danger signals, watchmen, and necessary appliances and safeguards to properly safeguard life and property. He shall also protect all excavations, equipment, and materials with barricades and warning signs and signals so that the public will not be endangered. The construction price to be paid by the Applicant/Owner shall include all costs for safety and protection of the public and his employees.
- E. Traffic. The Contractor shall so conduct his operations as to offer the least possible obstruction and inconvenience to traffic and the Public, and he shall have under construction no greater amount of work than he can handle properly with due regard for the rights of the public. All traffic shall be permitted to pass through the work with as little delay and inconvenience as possible, unless otherwise authorized by the governing agency. All traffic control shall be as directed by the jurisdictional agency. No road or street closures shall be permitted without San Diego County approval.
- F. Convenience of Abutting Owners. Convenience of abutting owners shall be provided for as far as practicable. Convenient access to mailboxes, driveways, houses and buildings adjoining the work, as well as fire hydrants and valves, shall be maintained and temporary approaches to intersections shall be provided and kept in good condition. When a section of surfacing, pavement, or a structure has been completed, it shall be opened for use by traffic at the request of the District. In order that unnecessary delay to the traveling public may be avoided, the Contractor, when so ordered, shall provide competent flagmen whose sole duty shall consist of directing traffic either through or around the work. The Contractor shall notify all emergency and community services 48 hours in advance of construction or detours on public streets. These shall include but are not limited to: ambulance, fire, sheriff, mail, school districts, bus services, and the newspaper.
- G. Private Contract Surveying.
 1. All surveying work shall be done under the direction and supervision of a Land Surveyor licensed by the State of California. Prior to beginning any phase of the survey work, the Contractor shall submit to the Engineering Manager, the Contractor's proposed plan for establishing lines and grades for control of the Project, including his plans and timetable for submitting data to the Engineering Manager during the course of the work.

2. All survey data shall be recorded in accordance with standard methods approved by the Engineering Manager. All original filed notes, computations, and other records for the purposes of layout shall be recorded in field books, or other methods acceptable to the Engineering Manager. The Contractor, immediately upon completing and reducing notes for a portion of survey, shall furnish four (4) copies to the Engineering Manager for review purposes.
3. With no exceptions and on all projects, "Cut Sheets" shall be forwarded to the Engineering Manager prior to staking and/or excavation. Any changes to the cut sheets shall be recorded as changes and a complete set of "Record Cut Sheets" shall be submitted to the Engineering Manager.
4. The Contractor shall layout the project by establishing all lines and grades at the site and along the pipeline alignments necessary to control the project and shall be responsible for all measurements, that may be required for the execution of the project, to the location and limit marks and tolerances prescribed in these specifications or on the plans.
5. The Contractor shall place and establish such additional stakes and markers as may be necessary for control and guidance of his construction operations and as required by the Engineering Manager. Grade stakes shall include the following: sewer line designation; station; invert elevation; and cut distance. Contractor shall protect in place all grade stakes and hubs during construction. If the grade stakes are removed, damaged, or knocked down during construction the stakes shall be replaced by the Land Surveyor at the Contractor's expense.
6. Prior to establishing any base line and grade stakes, the Contractor shall have all utility lines located and marked in the field and shall have all rights-of-way cleared to grade, and ready for construction activities.
7. The Contractor shall provide surveyed elevations of all constructed manholes at the end of construction and prior to acceptance by the Engineering Manager. Such submittal shall be signed by a California licensed Land Surveyor. Variation from approved design elevations may be cause for rejection and rework.
8. The Contractor shall protect property and monumentation and if such monumentation is destroyed by his operations, the Contractor shall at no cost to the Owner, have the monumentation replaced in accordance with the laws of the State of California, and in particular in accordance with State Assembly Bill 1414 including recordation, as required by law.

1.15 MATERIALS AND WORKMANSHIP

- A. New Materials. Unless otherwise specified, all materials incorporated in the permanent work shall be new. Materials not otherwise designed by detailed specification shall be of the best commercial quality and suitable for the purpose intended.
- B. Workmanship. All workmanship shall be in conformance with the best trade practices. Particular attention shall be given to the appearance of exposed work. Any work or workmanship not conforming to the best practices shall be subject to rejection.

1.16 PROJECT CLEANUP

The Contractor shall at all times maintain an orderly job. Tools, rubbish, and materials shall be picked up and stored in a workmanship manner or disposed of at all times. The Contractor shall remove from the vicinity of the completed work all material, etc., belonging to him or used under his direction during construction. Surfaces shall be returned to a condition acceptable to the District. All excess material shall be disposed of as directed by the District or removed from the job site.

1.17 GUARANTEE

- A. Defective Materials or Workmanship. The Contractor and Applicant shall guarantee all parts of the work against defective materials or workmanship and against settlement of backfill and damage to resurfacing for a period of one (1) year from the date of its acceptance by the District, as indicated by the recording date of the Notice of Completion.
- B. Repair Work. When defective material or workmanship is discovered in the work, requiring repairs to be made under this guarantee, all such repair work shall commence by the Contractor or Applicant at his own expense within ten (10) days after written notice has been given to him by the District and be completed in as short a time as necessary. Should the Contractor or Applicant fail to begin repairs as directed within ten (10) days thereafter or vigorously pursue the work, the District may make the necessary repairs and charge the Contractor or Applicant with the actual cost of all labor and materials required plus overhead. In emergencies demanding immediate attention, the District shall have the right to repair the defect or damage and charge the Contractor or Applicant with the actual cost of all labor and material required plus overhead. Emergencies shall be defined by the Engineering Manager, with no exceptions.
- C. Performance Bond. The Applicant shall furnish to the District, at no expense to the District, a bond for the performance of the foregoing guarantee in an amount of 100% of the construction cost of the total work which cannot be cancelled for a period of one (1) year.
- D. Labor and Materials Bond. The Applicant shall furnish to the District, at no expense to the District, a bond for the labor and materials of the foregoing guarantee in an amount of 100% of the construction cost of the total work which cannot be cancelled for a period of one year.
- E. Warranty Bond. Upon acceptance of the work, the Applicant shall furnish to the District, at no expense to the District, a bond for the warranty of the foregoing guarantee in an amount of 10% of the construction cost of the total work which cannot be cancelled for a period of one year.

1.18 REFERENCE TO PUBLICATIONS

Publications. Within these Standards reference is made to other publications. These other publications are made a part of the Standards whether in whole or in part as specified in each reference.

1.19 FEES

- A. Plan Checking Fees. Fees shall be paid as indicated in the RMWD Ordinances.
- B. Permits and Approvals.
 1. Prior to the construction of a water line and/or a sewer main and related appurtenances, the District shall collect from the Applicant the full cost of field

inspection for the proposed construction. The fee shall be paid as indicated in the RMWD Administrative Code.

2. The construction will not be allowed until the Applicant has obtained a City, or County Road Department Excavation Permit and/or State Highway Utility Encroachment Permit and the required set of prints have been submitted and approved by the District.
3. Recorded letter of written permission from the property owner shall be obtained by the contractor to access or perform work on properties other than the proposed project. All property damage shall be the responsibility of the contractor. Contractor shall video or photograph the property prior to construction and submit this evidence to the District prior to commencement of work.

1.20 EASEMENTS

The District requires separate water and/or sewer easement documents be submitted and recorded for each easement within a project. Easements indicated only on Tract or Parcel maps are not acceptable. The following procedure shall be followed in order to process private easements:

- A. Meet with the District to determine an acceptable location and width for the proposed easement. Minimum easement width is 20-feet for water and sewer only; 30-feet for both. Easements are to be dedicated to RMWD. Utility easements are not allowed.
- B. Prepare and submit two (2) copies along with the originals of the following documents prior to District approval of the easement:
 1. Original Grant of Sewer (Water) Easement form with original signatures from all legal property owners. The document must be notarized by a California licensed notary.
 2. Original Plat of the easement with a wet stamp and original signature from a California licensed Land Surveyor or licensed Civil who obtained a California license prior to January 1982.
 3. Original legal description of the easement with a wet stamp and original signature from a California licensed Land Surveyor or licensed Civil who obtained a California license prior to January 1982.

The District will not approve plans until the above items are submitted, reviewed and found to be recordable.

1.21 GENERAL NOTES AND REQUIREMENTS

- A. The Contractor shall notify the San Diego Gas and Electric Company; and Pacific Bell prior to starting work near company facilities and shall coordinate work with company representatives. For location of electric cable, gas piping and telephone cables and appurtenances, contact Underground Service Alert: 811, 48 hours prior to start of construction.
- B. The Contractor shall notify the Engineering Manager at least five (5) days prior to starting work, so that inspection may be provided. Telephone No. (760) 728-1178.
- C. Separation requirements between water and sewer lines shall conform to California Department of Public Health (CDPH) "Water Works Standards".

- D. All work shall be in accordance with the most recent editions of the California Occupational and Health Administration (Cal-OSHA) - California Code of Regulations (CCR) Title 8, Standard Specifications for Public Works Construction, with supplements (APWA specifications), the San Diego Regional Standard Drawings and RMWD Standards Manual.
- E. Prior to construction of the water and/or sewer lines, the contractor shall expose the existing water and/or sewer lines where connections will occur and verify their elevation and location. Approval by the Engineering Manager a proposed connection to a RMWD facility does not imply approval of the correctness of the elevation and/or location shown on the plans.
- F. Contractor shall not backfill trench until the District has inspected the pipe or structure and authorizes the trench to be backfilled. It shall be the Contractor's responsibility to provide accurate "record" drawings to the District immediately after construction.
- G. Approval by the District implies no permission other than that within the District's jurisdiction. All permits required by law shall be acquired by the applicant or his contractor. Requirements of RMWD shall take precedence over requirements of other agencies only where RMWD requirements are more stringent.
- H. The Contractor shall obtain an excavation permit from the Division of Industrial Safety.
- I. Pipe joints shall not be pulled at any angle greater than the maximum angle recommended by the pipe manufacturer.
- J. The proposed work shall be subordinated to any operations RMWD may conduct, and shall be coordinated with such operations as directed by the Engineering Manager.
- K. A preconstruction meeting shall occur prior to construction. Attendees shall include the Engineering Manager or his designate and the Contractor who will perform the work, and other governmental agencies and/or utility companies as necessary. "Cut-Sheets" shall be provided to the District prior to this meeting for review.
- L. Traffic Control shall be in accordance with the current State of California Manual of Traffic Controls. The contractor is responsible for all traffic control on the jobsite.
- M. The Contractor shall be responsible for implementing, administering and maintaining a confined space entry program and permit.
- N. Pipe shall be handled with straps (no chains) so as to protect pipe joints, lining and coating, and carefully bedded to provide continuous bearing and prevent settlement. Cable may be used only with prior approval from the Engineering Manager. Pipe shall be protected against flotation at all times. Open ends shall be sealed at all times when construction is in process.
- O. Upon completion of construction, the Contractor shall hire a video company approved by the District to videotape the CML&C water mains. The Engineering Manager will review said videotape for potential construction defects prior to acceptance of the project. Payment for all such services shall be borne by the Contractor.

- E. Contractor shall designate a qualified superintendent with full authority to act on behalf of the Contractor. Said superintendent shall be on the job site at all times.
- F. Contractor shall perform all encroachment permit work under San Diego County Department of Public Works, City of Oceanside or the City of Vista jurisdiction, Morro Hills Community Services District, in accordance with all requirements of said removal, temporary pavement placement, permanent pavement placement (including base material) and temporary and permanent traffic striping.
- G. The water line shall be installed by a private contractor with an "A" or "C34" License in accordance with RMWD Standards Manual. The Contractor shall be approved by the Engineering Manager.
- H. Minimum cover over the water main shall be 42-inches for pipes less than 12-inches diameter. and 48-inches for pipes 12-inches diameter, and larger, unless prior approval is obtained from the Engineering Manager.
- I. Wherever a water line encounters a storm drain pipe or other obstruction, and crossing over the obstruction will result in less than 30-inches of cover over the water line, it shall cross under the obstruction (12-inches minimum clearance).
- J. Meter boxes shall be field located to clear driveways and located accurately on the As-Built drawings. The Contractor shall adjust meter boxes to sidewalk grade when sidewalks are poured.
- K. All water mains and fire hydrants are District owned and maintained. The District maintains house water laterals from the mainline up to / including the meters.
- L. Contractor to adjust all valve covers, fire hydrants, meter boxes, etc., to grade as directed by the District.
- M. All new fire hydrants to be Clow 2050, OAE. for static pressure less than 200 psi. All new fire hydrants to be AVK, OAE. for static pressure greater than 200 psi.
- N. Laying direction of water main shall be in a general uphill direction.
- O. The location of air valves and blow-offs to be verified by the Engineering Manager in the field.
- P. All valves shall have access piping that consists of SDR35 or C900 and the 1208N lid covers. (RMWD Standard Drawings W-19 and W-20).
- Q. Water meter service laterals shall be 30-inches below finish ground level. Service stop shall terminate 9-inches below finish ground level with location stamped in curb. All others to terminate above ground.
- R. The Contractor shall install suitable thrust blocks at selected vertical and/or horizontal change of direction in accordance with RMWD Standards, whether or not specifically called for or shown on the Plan.

- S. Contractor to make connections to existing mains only after successful pressure testing and disinfection of new facilities as authorized by the Engineering Manager.
- T. All materials, testing and inspection of pipe shall be in conformity with the requirements of RMWD, and the American Water Works Association (AWWA) Standards. County, and/or the AWWA Specifications will be cause for rejection.
- U. All welded steel pipe used shall be cement mortar lined and coated, ¼-inch thick (minimum) with fully welded joints and hand holes, unless noted otherwise.
- V. All steel bends and fittings shall be cement mortal lined and coated and shall be shop fabricated per AWWA C-208-(latest). Contractor shall submit fabrication drawings (from a District approved fabricator) for all AWWA shop fabricated fittings to the District for approval prior to construction. Service connections made to existing ACP, DIP, or PVC pipelines shall utilize a brass double service strap connection.
- W. For hydro-static testing purposes, all water pipes shall be 50 psi above the class rating of the pipe at the lowest point in the section being tested; and shall be at least equal to the design class of the pipe at the highest point in the line.
- X. The minimum requirements of the pipeline trench shall be per RMWD Standard Drawing W-3.
- Y. Pipelines and appurtenances shall be tested, disinfected, and dechlorinated per RMWD Standards Section 15041, Department of Public Health, and/or any other agency having jurisdiction over the work.
- Z. Contractor shall uncover locations of connections prior to starting installations to ensure conformance with lines and grades shown on these plans. Any deviation from the plans must be approved by the District prior to construction.
- AA. The existence and location of water facilities as shown on the plans were obtained from available records. To the best of our knowledge, the existing water facilities are as shown on the plans. The District shall not be held responsible for any error in the location and elevation of the existing water facilities. The Contractor is required to take precautionary measures to protect any existing facility shown hereon and any other which is not of record or not shown on these plans.
- BB. Location and elevations of improvements to be done shall be confirmed by field measurements prior to construction of new work. The Contractor will make exploratory excavations and locate existing underground facilities sufficiently ahead of construction to permit revisions to plans if revisions are necessary because of actual location of existing facilities.
- CC. Call the District five (5) working days prior to starting construction, and two (2) weeks if shutdown is required. The District shall be notified at least two (2) working days prior to any inspection. To arrange for inspection, call (760) 728-1178.

- DD. Pipe deflections for short radius curves and angle points shall normally be accomplished by means of standard fittings, the locations of which shall be detailed on the plans.
- EE. All water used on a construction project must be paid for and will be metered. This includes water for loading of new waterlines, flushing of lines, pressure testing, etc. Citations will be issued to parties taking water from unmetered facilities. A construction water meter permit may be obtained from the District.
- FF. Sections of the filled water line that are referenced to this note shall be entirely shop fabricated (i.e., no welding will be allowed).
- GG. Proposed water system improvements are located within the _____ pressure zone (HWL = _____ FT. / FL = _____ FT.).
- HH. The Contractor shall install an isolation kit at points of connection of dissimilar material.
- II. Water meter abandonment/removal the service lateral at the mainline must be cut and a cap or plug must be installed into the corporation valve, encase abandoned corporation valve in concrete and remove the lateral from the corporation to the curb stop. Current inspection fees will be required. Shutdown fees may be required.
- JJ. High pressure notes on plans shall include:

This is a high pressure project. All pipe, fittings and appurtenance must meet pressure requirements.

1.23 SEWER NOTES AND REQUIREMENTS

- A. The sewer line shall be installed by a private contractor in accordance with the current RMWD's Domestic Water, Recycled Water and Sanitary Sewer Facilities Construction Standards Manual. The contractor shall be approved by the Engineering Manager.
- B. Type of sewer pipe and appurtenances used shall be in accordance with the Approved Materials List.
- C. Grading over sewer mains shall be done in such a manner as to prevent the ponds of water.
- D. The top of all manholes located in pavement shall be raised to pavement grade after streets are paved. All manholes in unimproved areas shall be 6-inches above the ground surface. Manholes located within DG roads shall have an 8-inch PCC collar and rest 3-inches above the ground surface.
- E. House connections, wyes and laterals shall be installed per RMWD Standard Drawings. Wyes and laterals shall be maintained by the property owner. The property owner is responsible for the lateral up to connection to the main per RMWD Standard Drawings S-8 and S-9.

- F. The minimum class bedding for PVC sewer shall be in accordance with RMWD Standard Drawings.
- G. The Contractor shall successfully perform one (1) air test on all sewer lines, in accordance with the test procedures outlined in Green Book Section 306-1.4.4, Amendment 306-1.4.4.1, and the Low Pressure Air Test for Sanitary Sewers as published by the National Clay Pipe Institute. All necessary test equipment shall be furnished by the Contractor and the test shall be made only after the line has been properly installed including any necessary test fittings, and backfilled. The Contractor shall conduct the air test at no cost to the District.
- H. Sewer laterals crossing existing curb and gutter shall be backfilled with 1-sack cement, sand slurry backfill.
- I. Connections to existing pipelines shall only be made with the Engineering Manager present. Test plugs shall only be removed upon direction of the District .
- J. Should modification and/or reconstruction (including raising manholes to grade) of an existing manhole be required, prior to the removal of the frame of sewer manhole, the channel of the manhole shall be completely covered with planking or other suitable material so as to prevent debris from entering the channel. After the manhole reconstruction has been completed, all debris shall be removed from within the manhole and the cover over the channel shall be removed.
- K. Upon completion of construction, the Contractor shall hire a video company approved by the District to videotape the sewer mains. The Engineering Manager shall review said videotape and written findings for potential construction defects prior to acceptance of the project. Payment for all such services shall be borne by the Contractor. Contractor shall submit to District voice disc, and hard copy, of lateral distances and any problems.
- L. New sewer mains shall remain plugged and/or disconnected until the Engineering Manager authorizes its use.
- M. Prior to acceptance of any sewer line by the District, all lines shall be flushed clear using "Wayne Ball" and mandrel tested.
- N. Rainbow Municipal Water District will only maintain sewer mains located in right-of-way easements dedicated to RMWD, which have permanent all weather vehicle access.
- O. Manhole lining notes on plans shall include:

All new manholes on sewers 18-inches or greater diameter, or where entering pipe slope is 5% or greater, or within 1,000-feet of a receiving force main discharge, existing manholes with new connections and in high groundwater areas shall be provided with integrally locking PVC or polyurethane protective lining system and manhole covers shall include odor control inserts.

1.24 RECYCLED WATER NOTES AND REQUIREMENTS

- A. In general, public recycled water facilities shall be installed in accordance with the requirements for potable water materials and facilities as detailed in the current RMWD's Domestic Water, Recycled Water and Sanitary Sewer Facilities Construction Standards Manual, except as modified or expanded upon herein.
- B. Field Identification – Recycled water piping and appurtenances shall be identified with purple colored coding and identification labels and signs as specified herein.
1. All new buried constant and intermittent pressure mains and transmission and distribution piping in the recycled water system, including service lines, valves and other appurtenances shall either be colored purple and embossed or be integrally stamped/marked **“CAUTION: RECYCLED WATER – DO NOT DRINK,”** as manufactured or be installed with an 8 mils purple colored high-density polyethylene encasement sleeve that is printed with the text “Caution Reclaimed Water - Do Not Drink” that totally encloses the pipe.
 2. Minimum 6 inch wide Recycled Water Identification tape shall be installed 2-feet below finish surface and centered over the pipe. The identification tape shall be continuous in its coverage over the pipe and shall visibly extend into valve, blow-off and meter boxes.
 3. Meters, blow-off piping and blow-off box covers or blow-off manhole covers, valve box lids, air valves and enclosures, piping, valves, backflow devices and all other items either accessible or exposed to view, shall be identified by means of the purple coating or integral purple color. The coating system shall be suitable for the substrate material and the degree of protection required for the various items, in accordance with these specifications.
 4. Valve box lids shall be cast with “RECYCLED WATER” and valve boxes and lids painted purple, color Pantone 522C.
 5. Locator wire shall be installed in accordance the District's Standards and specifications.
- C. Labels and Signage
1. Labels shall be installed on recycled facilities exposed to view including above ground piping and appurtenances. Warning signs and labels shall read **“CAUTION: RECYCLED WATER - DO NOT DRINK”**, and should be in both English and Spanish. The signs should include the international symbol for do not drink.
 2. In a fenced area (e.g. pump station area), at least one sign shall be posted on the fence that can be readily seen by all operations personnel utilizing the facility.

D. Disinfection and Bacteriological Testing in the event the recycled water mains are installed with provisions for future use for transporting recycled water, but will initially transport potable water, disinfection, flushing, and bacteriological testing shall be performed in accordance with the District's Standards and Specifications.

E. Hydrostatic Testing

Potable water shall be used for filling, flushing, and hydrostatic testing. Field hydrostatic testing shall be performed in accordance with the District's Standards and Specifications.

F. Backflow Prevention

During the course of flushing, disinfection, and hydrostatic testing of the recycled water mains, an appropriate reduced pressure backflow prevention device shall be installed on the potable source piping to isolate the potable from the non-potable system.

END OF SECTION 1

DESIGN

REQUIREMENTS

SECTION 2

DESIGN REQUIREMENTS

2.01 GENERAL WATER AND SEWER REQUIREMENTS

All proposed work shown on plans submitted for approval shall be designed according to these standards. In all matters the Engineering Manager's decision shall be final.

These guidelines have been developed to assist consulting engineers and developers of any type of development or improvement which requires connection to Rainbow Municipal Water District's existing water or sewer systems. The guidelines presented herein are acceptable to the District and following them will require the least amount of review time.

Every effort was made to provide criteria for any situation that may come up in the design process, however, the private engineer's ultimate aim should be directed toward providing a water system for both domestic and firefighting purposes and a sewer system to accommodate the design waste flows as indicated in this document. However, all plans showing water or sewer systems shall be subject to review and final approval by the Engineering Manager.

The Engineering Manager, at his discretion, may grant exceptions to these Standards, providing such exceptions will substantially conform to the intent of these Standards. No exceptions will be granted without the express written consent of the Engineering Manager.

2.02 WATER REQUIREMENTS

A. SYSTEM CAPACITY

The capacity of the water distribution system shall deliver the maximum daily demand *simultaneously* with the required fire flow at a minimum residual pressure of 20 psi at all fire hydrants. Demand factors are calculated as follows:

$$\text{Maximum Daily Demand} = 2 \times \text{Annual Average Day}$$

$$\text{Maximum Hour Demand} = 4.5 \times \text{Annual Average Day}$$

The distribution system shall also deliver the peak hour flow without fire flow. The Engineering Manager may require certain mainlines to be oversized to facilitate future growth.

B. POTABLE WATER USAGE

Domestic Water Consumption	Average Daily Demand
Single Family Dwelling Unit	900 gal/unit
Duplex	600 gal/structure
Multi Family Dwelling Unit ¹	300 gal/unit
Commercial	3,000 gal/acre
Commercial/Industrial	100 gal/1,000 sf
Hotel ²	240 gal/room
Schools	60 gal/student
Parks	4,000 gal/acre
Agriculture	1,000 gal/acre
¹ Unit refers to individual apartment, etc.	
² Assumes 80% occupancy.	

The guidelines for water usage are subject to review by the Engineering Manager based on the many variable factors that influence water consumption rates.

C. PIPELINE SIZING

Pipelines shall be sized to provide the required capacity as indicated in Paragraph 2.02A of this section. The design shall accommodate requirements for maximum hour or maximum daily demand plus fire flow, whichever is greater.

Design calculations shall be done by a registered engineer and submitted to the District for approval. The minimum main size shall be 8-inch for all zones, except Commercial and Industrial zones which shall have a minimum 12-inch mainline size. Acceptable main line sizes are 8-inch, 12-inch, 16-inch and 24-inch only. Variations from this standard must be approved by the Engineering Manager, but in no case will variations be allowed that are in conflict with Section 64628 or Title 22 of the California Administrative Code.

Oversizing of a mainline can be required by the Engineering Manager for future development. If oversizing is required by the District, the District’s Board of Directors may authorize payment to compensate the developer for the oversize. Only mainlines greater than 12-inches in diameter may be eligible for reimbursement and only if the oversize is required by the Engineering Manager.

All pipes must be sized in accordance with the current version of the Water Master Plan for RMWD unless approved by the Engineering Manager. All pipes must be sized so that the velocity shall not exceed 5-feet per second during peak hourly flow and 10-feet per second at maximum day plus fire flow.

D. HORIZONTAL ALIGNMENT

When possible, all water mains shall be located in the paved street, 7-feet south or east from the face of the curb unless otherwise required to clear obstructions. Water mains installed in easements shall be centered within the easement when possible. The location for any mainline within easements shall be approved by the Engineering Manager. When a roadway has not been completely developed, the District may elect to locate the main in

the unpaved portion of the right of way in order to align the pipe with the future paved roadway.

On side hill streets, the main shall be located on the cut side of the center line of the street or on the high side of super-elevated curves. Where the water main is to parallel a sewer or storm drain, there shall be a minimum horizontal clearance of 10-feet from the sewer or storm drain or other wet utilities unless otherwise approved by the Engineering Manager. The separation of water and sewer lines must comply with the California Department of Health requirements. No gas or sewage main, electric, telephone, or cable television, or other utility line shall be installed in the same trench with any water mains or water lateral.

Where waterlines may be extended for future growth of the water system, the waterline must extend across the entire frontage of a lot or parcel. At the end of a street which may be extended in the future, the water main or sewer main shall be extended across the end of the last parcel or lot split or to a point beyond the permanent street paving. Water mains must be looped as required by the Engineering Manager and the Water Master Plan.

E. VERTICAL ALIGNMENT

Invert grades of water mains shall provide minimum and maximum cover requirements as specified below and also ensure proper clearance between top of valves and valve box covers. Minimum cover from grade to the top of pipe for all water mains shall be as follows:

<u>Pipe Size</u>	<u>Minimum Cover</u>
Less than 12-inch	3.5-feet
12-inch and greater	4.0-feet

Maximum cover for all mains shall be 8-feet unless approved by the Engineering Manager.

No mains or service laterals shall be surface installed except in temporary situations as necessary to maintain service during construction or maintenance. Each case must be approved by the Engineering Manager prior to construction.

F. PIPE MATERIALS

Water mains shall be CML&C Steel Pipe, Ductile Iron or PVC. Joints shall be welded joint, push-on joint, mechanical joint or flanged joint. In all cases, the Engineering Manager reserves the right to specify the type of pipe, joint, or class of pipe to be used.

The class of water mains shall be determined by the maximum pressure to be expected in the line including pressures resulting from surges. Rainbow Municipal Water District's water system has some very high pressures and District will not allow materials that may compromise the quality of the piping system. The class of pipe and test pressure shall be shown on the plans.

G. VALVES

Valves shall be located at all branches or intersections of mainlines. The valves shall be flanged and be bolted onto a cross or tee. Line valves located away from intersecting lines may be push-on or mechanical joint.

All water system designs shall include valves so that the spacing between valves shall be less than the following:

1. 1,000-feet for transmission mains 16 inches or larger
2. 750-feet in residential areas.
3. 500-feet in all other areas.

Where a new main is connected to an existing main, valves on both the new and the existing mains shall be installed as required above (where the Engineering Manager determines that it is impractical to shut off an active main for connection, a tapping sleeve with tapping valve may be allowed). Valves may be required near the end of a main line that will be extended in the future to minimize the number of times live mains are shut down.

No valve shall be installed where the invert slope of the mainline exceeds 6%. Valves shall be located so that there will be minimum clearance of 6-inches between the top of the valve and the bottom of the valve box cover.

All valves shall be a rated for the working pressure of the mainline. The class of valve shall be shown on the plans. RMWD has many areas where pressures exceed 250 psi and the Engineering Manager must specify the use of appropriately classed valves.

Specific types of valves shall be as follows except when approved by the Engineering Manager:

1. Resilient wedge gate valves will be used for all lines where static pressure is less than 150 psi.
2. High pressure resilient wedge gate valves will be used where static pressure is between 150 psi and 250 psi.
3. Plug valves shall be used where static pressure is 250 psi or above.

H. BLOW OFF ASSEMBLY

1. Blow-off assemblies shall be installed at all system and local low points. Blow-off assemblies shall be as shown on the RMWD Standard Drawing except that the size shall be determined in accordance with accepted practice. Whenever possible, blow-off assemblies shall be installed at the BC or EC on curb returns. Fire hydrants, Wharf heads shall be used whenever indicated by the Engineering Manager.
2. Blowoff assemblies shall be sized and located as shown on the RMWD approved plans. Generally, blow-offs will be located at the end of a pipeline or at a low spot on a given pipeline. Water mains 16-inches and smaller 4-inch blow-offs shall be installed. Water mains larger than 16-inches and 6-inch blow-off assemblies shall be installed.

Water mains 8-inches or smaller a 2-inch blow-off valve may be allowed under special circumstances and only as approved by the Engineering Manager.

I. AIR RELEASE AND VACUUM RELIEF VALVES

Air release and vacuum relief valve assemblies shall be installed at all system and local high points and just downstream of shut-off valves. Whenever possible, air release and vacuum relief valve assemblies shall be installed at the BC or EC on curb returns. Air release and vacuum relief valve assemblies shall be as shown on RMWD Standard Drawing and sized in accordance with the manufacturer's requirements. Calculations for sizing of air release and vacuum relief valves shall be submitted for approval. All Air Vac assemblies shall be capped. (RMWD Standard Drawings W-11 and W-12).

J. FIRE HYDRANTS

Fire hydrants shall be installed in locations and spaced as directed by the Fire Department and conform to the RMWD Standard Details. The fire flow requirements are as required by the Fire Department. Under special conditions, the Engineering Manager may require higher fire flows. Unless otherwise directed by the Engineering Manager or the Fire Department, the location of hydrants shall conform to the following requirements:

1. Hydrants shall be located in front of a boundary line between lots.
2. Hydrants shall be located on the cut side of side hills
3. Whenever possible fire hydrant assemblies shall be installed at the BC or EC on curb returns
4. All fire hydrant shut-off valves will be securely fastened directly to the distribution main by a tapping sleeve and valve or by flanging the valve onto a flanged tee.
5. As-built plans must show actual fire flow and pressure with date and time of test for each hydrant. Pressure data is to include static and residual pressure during the test per AWWA testing procedure.
6. Direction of the 4-inch outlet shall be a 90° angle to the road. Any deviation shall be subject to the approval of the Fire Marshal. (RMWD Standard Drawings W-9 and W-10).

K. DEAD END MAINS

All dead end water mains shall have provisions for flushing. Extending a fire hydrant or blowoff directly off the end of the mainline is acceptable.

L. WATERLINE CROSSINGS

Where proposed water mains cross or are constructed parallel to any proposed sewer, storm drain or recycled water facility the water mains shall have their invert elevation a minimum of 1-foot higher elevation than the top of the other utility. Any deviation to this design parameter must be approved by the Engineering Manager. The requirements of

the California Department of Public Health for water crossings shall be enforced in all situations.

M. CORROSIVE SOILS

A soils report is required with the first plan check for all improvement projects and shall specify potentially corrosive soils based on soil boring samples and laboratory analysis. Based on the soils report, the Engineering Manager may require corrosion protection methods be implemented as part of the project. This implementation may include, but is not limited to, design drawings and Specifications created by a licensed Corrosion Protection Engineer.

In all cases, the details of the materials and methods to be used shall be as approved by the Engineering Manager. If cathodic protection is required, it shall be designed by a licensed Corrosion Protection Engineer and approved by the Engineering Manager.

N. WATER SERVICE CONNECTIONS.

Services and connections on water mains shall be installed for each property in accordance with the Standard Details. Where practical, services shall not be located adjacent to electric, telephone, and sewer lines leading into the property to be served. Only one (1) meter shall be connected to a single service lateral. All services shall be located at right angles to the distribution main except to serve rear lots per RMWD Standard Drawing W-17. The property to be serviced must abut a water main and a reduced pressure regulator must be installed on the water meter if the pressure is greater than 150 psi.

Service stops shall be installed such that: While standing on the District side of the meter box, the locking wing is located on the left side of the service lateral with the lock.

Services shall not be connected to 16-inch or larger mains unless specifically permitted by the Engineering Manager. Service connections of appropriate size shall be provided to connect such lateral with each meter site. Services shall have a minimum cover of 30-inches within the street pavement area. No services shall be high-lined.

The size, location, and type of material of each service shall be indicated on the Construction Plans. Each residential unit requires a minimum 1-inch service line with a 1-inch meter. Design calculations used to size the services shall be submitted to the Engineering Manager for approval.

Services and connections shall be of type K copper with appropriate valves, stops, and fittings, and anodes as shown in the Standard Details. Services shall be connected to the main in accordance with the Standard Details. Meter boxes shall be furnished by and installed by the Contractor as shown on the Standard Details. Meter boxes shall not be installed in driveways or sidewalks.

O. BACKFLOW PREVENTION

All irrigation meters and meters for commercial and industrial users require a reduced pressure principal backflow prevention device. Unless otherwise directed by the

Engineering Manager the location of the approved assemblies shall conform to the following requirements:

1. Backflow preventers shall be located on the customer side of the service meters.
2. Backflow preventers shall be located no more than 8-feet maximum from the water meter and encased with slurry or a brass nipple, and be accessible for inspection.
3. No unprotected branch connections shall be allowed between the meter and the backflow device. (RMWD Standard Drawings W-1 and W-2).
4. Backflow devices will be the same size as the meter when upsizing.
5. The degree of hazard and property size will determined the type of backflow preventer. A Reduce Pressure device would be required for high hazard regardless of property size.

P. HOT TAPS

Hot taps to an existing water line are allowed for water services, fire hydrants, air release and vacuum relief assemblies, and blow off assemblies. All hot taps shall be done only with the approval of the Engineering Manager. All hot taps shall be made with the Engineering Manager present.

All Hot Taps done on Asbestos Concrete Pipe shall utilize a ROMAC JCM 432 SST tapping sleeve or approved equal. The ¾-inch test plug shall be removed and a pressurized water hose shall be attached and turned on while drilling is being conducted in order to flush out excess debris. The test plug shall be replaced after drilling and tightened in accordance with the manufacturer's recommendations.

Q. TIE-INS

Prior to construction, the Contractor shall pothole the existing pipe at the location of the proposed connection. To facilitate the proposed connection and allow for slight adjustments in alignment, the Contractor shall leave a minimum 10-foot gap between the new pipe installation and the proposed connection point at the existing water main or as directed by the Engineering Manager. The new pipeline shall have successfully passed pressure testing in accordance with Section 15044 and disinfection and bacteriological testing in accordance with Section 15041 prior to proceeding with the connection to the existing pipeline.

All tapping valves, saddles, and fittings must be disinfected prior to use. The Engineering Manager may postpone or reschedule any shutdown operation if, for any reason, the Engineering Manager believes that the Contractor is improperly prepared with competent personnel, equipment, or materials to proceed with the connection.

R. SYSTEM LOOPING

System looping wherever possible and practical shall be provided. All new pipelines of at least 8-inch in size in the water system shall be evaluated, and if possible and practical,

the new line will be required to be looped with adjacent infrastructure. Therefore, it is the responsibility of the developer to consult with the Engineering Manager for an evaluation of each pipeline to determine the need for system looping and other system reliability issues. The developer is responsible for constructing the looped pipeline, as a condition of the District's acceptance of the facilities for water service by the District.

2.03 SEWER REQUIREMENTS

A. GRAVITY PIPELINES

No public collection sewer shall be less than 8-inches in diameter. Oversizing of a mainline or forcemain may be required by the Engineering Manager for future development. If oversizing is required by the District, the District's Board of Directors may authorize payment to compensate the developer for the oversize. Only mainlines over 12-inches in diameter and forcemains greater than 8-inches may be eligible for reimbursement and only if the oversize is required by the Engineering Manager. The following criteria shall be used in determining the size of pipes:

1. Flow estimates shall be determined as the product of the number of equivalent dwelling units (EDUs) and a unit flow factor. Flow factors for average and peak flows are presented in the following paragraphs.
2. Average Flow - A flow factor of 250 gpd/EDU shall be used to calculate average sewage flows. Table 1-2-1 presents EDU Factors adopted by RMWD Ordinance that shall be used to determine the number of EDU's for a given land use.

EDU FACTORS

	LAND USE FACTORS	EDU(s)
1	Average Single-Family Residence (2.58 Bedrooms on Individual Parcel)	1.00
2	Apartment House or Condominium Complex, Per Unit	1.00
3	Mobile Home Parks – Each Mobile Home Space, Each Office, Service Building or Other Accessory Building	0.80
4	Residential Second Units (Single Bedroom and Kitchenette)	0.40
5	Motel or Hotel	
	* Each Living Unit With a Kitchen	0.80
	* Each Living Unit Without a Kitchen	0.40
6	A Separate Business, Retail Shop, Office or Packing House Equipped with Restroom Facilities or Not So Equipped but Located in a Building or Complex with Common Restroom Facilities	
	* Up to 1,000 Square Feet of Floor Space	1.20
	* For Each Additional 1,000 Square Feet of Gross Floor Space or Part Thereof	0.80
7	Automobile Service Station	
	* Providing RV Holding Tank Disposal Station	2.00
	* Four or Under Gas Pumps	0.80
	* Over Four Gas Pumps	1.00

8	Church, Fraternal Lodge or Similar Auditorium; For Each Unit of Seating Capacity for 200 Persons	1.00
9	Bakery	1.00
10	Theatre: For Each Unit of Seating Capacity for 200 Persons	1.40
11	Hospital, Per Bed	0.40
12	Convalescent or Boarding Home, Per Bed	0.40
13	Labor Camp, Per Bed	0.10
14	Schools (Public or Private)	
	* Elementary Schools, Per Each 60 Students or Part Thereof, Plus Staff	1.20
	* Junior High Schools, Per Each 40 Students or Part Thereof, Plus Staff	1.20
	* High Schools, Per Each 30 Students or Part Thereof, Plus Staff	1.20
<i>(The number of students shall be the rated capacity of planned schools as determined by State of California Department of Education or shall be the average daily attendance of students plus the staff at the school during the preceding fiscal year determined in accordance with the Education Code of the State of California)</i>		
15	Mortuary	1.20
16	Car Wash	1.20
17	Grocery Store	1.20
18	Self-Service Laundry, Per Each Washing Machine	0.40
19	Restaurants	
	* Base (Using Non-Disposable Tableware)	2.70
	Add Per Each 7 Seats or Part Thereof	1.20
	* Base (Using Disposable Tableware)	1.20
	Add Per Each 21 Seats or Part Thereof	1.20
20	Swimming Pool with Restrooms	1.20
21	Spas with Restrooms	1.20
22	Country Clubs with Common Restroom Facilities – Each Additional Shower Unit, Wash Closet or Fixture	1.20

3. All sewer gravity lines 15-feet or deeper shall be C-900.
4. Design Peak Flow shall be 3x Average Flow. Sewers greater than 12-inches in diameter shall be designed with a d/D of 2/3. Sewers 12-inches in diameter and less shall be designed for a d/D of 1/2. Deviation per the discretion of the Engineering Manager.
5. A value of 0.010 shall be used as a coefficient of roughness equivalent to Manning's "n" or as approved by the Engineering Manager.
6. All sewers shall be designed and constructed with hydraulic slopes sufficient to give mean velocities at design day quantities of flow of not less than 2-feet per second. Maximum velocity shall not exceed 10-feet per second.
7. Following are minimum slopes that should be provided. These are guidelines that shall be verified by the design engineer with calculations showing a cleansing velocity of 2-feet per second, provided to the Engineering Manager.

<u>Sewer Size, Inches</u>	<u>Minimum Percent Grade</u>
8	0.4%
10	0.32%

12	0.24%
15	0.15%
18	0.12%

8. All sewer main pipe inverts shall be shown on profile on the improvement plans and shall include stations, slope and distance.
9. When cleansing velocity does not meet 2-feet per second a minimum of 2% slope is required. Depth of sewer line may be adjusted to meet requirement of the Engineering Manager.

B. SEWER FORCE MAINS

1. Force mains may not be constructed in the same trench as sewers. Minimum separations from waterlines shall be those specified for sewers. Insofar as practicable, force mains shall be laid at continuously ascending grades without intermediate high points or low points.
2. Minimum cover for force mains shall be 4 feet from finish grade to top of pipe, plus additional vertical clearance to locate sewage-type (long-body) combination air release and air and vacuum release valves and appurtenances below ground. Top of pipe profile shall be shown on the profile.
3. Size of force mains must be considered in conjunction with characteristics of the pumping equipment to be provided. In general, the design rates of flow shall be not less than 3-feet per second nor higher than 8 feet per second. Every attempt should be made to limit the maximum retention time in force mains to six (6) hours.
4. Unless otherwise approved or specified, force mains shall be minimum Class 200, PVC C-900 or C-905. Other materials shall only be used if approved by the Engineering Manager.
5. Low points in force mains shall be fitted with approved blow-offs (drains). High points shall have approved appurtenances for air release and air and vacuum release with carbon filter.
6. Thrust restraint calculation shall be submitted to the Engineering Manager for review and approval. Restraint may be provided either by restrained joint pipe or by thrust blocks.
7. Show all minimum clearances of other underground utilities in both plan and profile per State Department of Public Health Services "Criteria For The Separation Of Water Mains And Sanitary Sewers."
8. The minimum force main size is 4-inches.

C. LIFT STATION DESIGN

Public and private wastewater lift stations shall be avoided whenever possible. Specific written agreement from the Engineering Manager for the use of a lift station is required prior to approval of grading or improvement plans. If a lift station is approved, the design

engineer shall submit a lift station basis of design report to the Engineering Manager for review and approval. After approval of the basis of design report, subsequent plan and specification packages shall be submitted to the Engineering Manager for review and approval.

Lift station plans shall include pump curves, specifications, details, pump head, pump horsepower, pump capacity, electrical layout, control system layout-out, and schematics.

Sewer lift stations should be designed based on the projected peak wet weather influent flow.

Each lift station shall be provided with two (2) independent sources of power. This could be accomplished by providing an on-site generator with an on-site fuel source in addition to the electrical supply. The generator shall be located in a building or under cover and shall meet all regulatory requirements.

Every sewer lift station shall be designed in accordance with the following criteria:

1. Pumps
 - a. The minimum pump cycle time shall be in accordance with the pump and motor manufacturers' requirements. Note that larger motors require longer times between starts. Also, see other wet well sizing requirements related to minimum pump cycle time.
 - b. The minimum number of pumps per station shall be one (1) duty pump and one (1) standby pump of the same size.
 - c. The minimum non-clog sewage pump size shall be 4-inches with the capability to pass a 3-inch sphere. Where smaller pumps (capacity) are required, grinder type pumps shall be used.
 - d. Pump/system curve data shall include the following: system curve, design operating point, required net positive suction head (NPSH), hydraulic efficiency, Hp requirements, RPM, and other operating conditions required for each pump.
 - e. The most efficient pump performance shall be at the design Total Dynamic Head (TDH). Avoid pumps with "flat" pump curves where a small change in TDH will result in a large change in pump flow.
 - f. A factory certified pump test curve for the actual pump units to be installed at the station shall be required. Smith and Loveless, Gorman Rupp, Myers Lift Station, Xylem lift stations.
 - g. The specified operating point shall be near the maximum efficiency point on the pump curve and within the manufacturer's recommended limits for radial thrust and vibration. Select a pump curve where the operating point will near the center of the pump recommended operating range. Pump equipment shall be dynamically balanced to prevent vibration. No surge cavitation or vibration shall be allowed within the limits of the stable operating range indicated on the pump curve.

- h. If pumps have a water lubricated packing system, it shall be constant pressure type, and shall exceed the pressure of the pump. Water shall be supplied to the packing water system through an air gap tank and repressurization system installed in a location that is unconfined and above grade.
- i. Edges on pump bases shall be chamfered.
- j. For suction lift type pumps, TDH calculation must include the static suction lift elevation.
- k. Self priming pumps may be allowed for above ground stations with a maximum suction lift of 10 to 20-feet.
- l. Submersible pumps/motors, with stainless steel rail system, may be considered for direct installation in a wet well at the discretion and approval of the Engineering Manager. Including stainless steel guides and chains.

2. Piping and Appurtenances

- a. Pump isolation valves (suction and discharge) shall be plug valves with suitable operators per manufacturer's recommendations.
- b. Check valves shall be between pump and discharge plug valve, with external spring-loaded arm.
- c. Discharge line and manifold shall be supported and braced. Install sleeve couplings and/or flange coupling adaptors restrained by tie rods on the discharge piping for ease of removal of piping. These fittings will also prevent uneven tightening of flange faces.
- d. Sleeves shall be used for wall penetrations for pump suction lines and manifold discharge line.
- e. In manifolds, "Wyes" are required and shall be the same size as the manifold. Wyes shall be installed for horizontal side entry. Vertical entry shall not be allowed.
- f. Potable water services (for wash-down) shall not be smaller than 1-inch, and shall have an approved backflow prevention device. Wash down hose bibbs shall not be located in confined or below grade locations.
- g. On suction and discharge piping connected to each pump and on the discharge manifold horizontal and vertical runs, install a flexible coupling adaptor with tie rod thrust restraint to absorb vibrations and prevent stress in the pipe, and to allow minor adjustments in piping installations during construction between fixed well flanges. Piping supports under the suction and discharge lines shall be provided.
- h. Pipe joints must be restrained. The following types of joints are acceptable: flanged, dresser type coupling restrained by tie rods, mechanical joint with set bolt retainer gland.

3. Controls

- a. Each pump shall have a hour-meter, capable of reading 1/10th hour.

- b. Pumps shall operate in a duty/standby mode, with alternators to switch pump starts after each pumping cycle.
- c. All pump stations shall be equipped with District approved instrumentation and telemetry, which shall be compatible with the District's Supervisory Control And Data Acquisition (SCADA) System.
- d. All electrical wiring, fixtures and equipment shall conform to all safety codes.
- e. Pump control shall be via a ultrasonic level sensing and pump control system with float compressor back-up bubbler for emergency pump start and stop.

4. Alarms

- a. Emergency storage shall have an alarm.
- b. Wet well shall have a high level and low level alarms independent from the pump controls.
- c. Instrumentation and alarms shall be telemetered to District offices.
- d. Power outage alarm.

5. Ventilation

Ventilation requirements shall conform to current CAL-OSHA (confined space regulations) and NFPA 820.

6. Wet well

- a. Every lift station shall be provided with emergency storage separate from the wet wells. The minimum storage volume shall be equal to six (6) hours of wet weather flow, unless otherwise approved by Engineering Manager. The volume of emergency storage may be adjusted based on site specific conditions and proximity of sensitive receiving areas.
- b. The distance between the wet well floor and the turned down bell mouth suction inlet of diameter "D" shall be a maximum of D/2 and a minimum of D/3.
- c. Wet well level shall readout in "inches of water."
- d. Wet well walls and ceiling shall be PVC lined with polyurethane protective lining system, or approved equal substitute.
- e. Wet well floor shall be sloped toward the suction piping at 1/8 inch per foot.
- f. Inlet into the wet well shall be above the high water operating level in order to allow for the free flow of the gases into the wet well.
- g. Lift stations receiving flow from trunk sewers (18-inches or larger) shall have barscreens.
- h. Wet wells shall be designed to allow for the maintenance of wet well.

- i. The wet well shall be as small as possible to prevent septic action from taking place during periods of very low flow. However, the wet well must be large enough to provide at least 5 minutes pump running time at low flow to prevent overheating of the electric motor and controls. Designer shall provide written minimum running time confirmation and recommendation from the specified pump manufacturer for the specific application. Provide at least one (1) 48-inch diameter access manhole cover over wet well. (RMWD Standard Drawing S-7). Do not provide steps or ladder for access into the wet well.
- j. Wet well volume to be calculated as follow:
 - $Q_{\text{peak}} = (Q_{\text{avg}} \times \text{peak factor})$
 - $Q_{\text{design}} = Q_{\text{peak}}$
 - $Q_{\text{low}} = \text{average flow/peak factor}$
 - Min Wet well operating volume = $(Q_{\text{design}} - Q_{\text{low}}) \times 5 \text{ Minutes}$
 - Depth of wet well = wet well volume/wet well area = (high level - low level)
 - Wet well operating volume = volume between pump start and pump stop levels
- k. The exterior surface of wet wells shall be adequately water proofed to prevent intrusion of ground water.
- l. Provide facilities for odor control. The odor control facilities shall be approved by the Engineering Manager.
- m. Every lift station will be designed with 100% redundant wet well capacity in the form of a second wet well. The two wet wells must be hydraulically connected and able to function independently, with a minimum of 1 pump installed in each wet well.
- n. Minimum operating level between low and high alarms is 60-inches.

7. Other Items

- a. Prior to finalizing design, the Applicant's Engineer shall provide one (1) Operations and Maintenance manual to the Engineering Manager for review and approval. Three (3) copies of Operations and Maintenance manuals shall be provided with the final design.
- b. If other design problems occur which are not covered herein, such as siphons, industrial waste treatment facilities, etc., consult the Engineering Manager for general requirements.
- c. All sewer lift stations are required to contain a flow meter.

D. MANHOLES

Manholes shall be installed on sewers at all changes in slope, size of pipe, or alignment, at ends of all mains, and at all intersections of main line sewers. The maximum spacing allowable between manholes is 300-feet. Clean outs are not allowed in lieu of a manhole. Drop manholes are not allowed.

A minimum drop 0.10-foot and a maximum of 0.60-foot shall be used on a straight-through line. For a 90 degree bend through the structure, a minimum of 0.20-foot and a maximum of 1.00-foot shall be used. Minimum does not apply to sewers greater than 18-inches.

Where a proposed sewer connects to an existing manhole, the elevation of the inlets and outlets shall be shown in profile as determined by actual survey. If an existing sewer is straddled by a new manhole, the elevations of the proposed manhole shall be determined by actual survey. The applicant's private engineer shall submit the field notes.

All standard manholes shall be 48-inches minimum diameter with a minimum 36-inches entrance, with no steps. Five-foot diameter manholes shall be used when pipe diameter exceeds 15-inches or when depth exceeds 12-feet.

E. HORIZONTAL ALIGNMENT

In general, sewers should be located in public streets parallel to and along the street centerline. The standard minimum distance between the sewer and other utilities is 5-feet outside of pipe to outside of pipe, except for water lines, which shall be 10-feet outside of pipe to outside of pipe.

Scaled detail plans shall be provided for all manholes with multiple angled inlets and outlet. Plans shall show adequate clearance provided between manhole base penetrations to assure clearance and water tightness.

In all streets, the pipe is to be along the street centerline where possible. Pipe shall not be located in median strips or parking lanes. On curved streets, pipe shall parallel as nearly as possible the street centerline.

F. CURVED SEWER

Curved sewers shall be designed using the following requirements:

1. No vertical curves will be permitted.
2. Horizontal curves shall match the centerline radius of the road in which the sewer main is to be installed. Curves in sewer pipe shall be as recommended by the pipe manufacturer with a minimum radius of 200-feet.
3. Joint deflections shall not exceed 1 degree or the manufacturer's recommendation, whichever is less.
4. Manholes are required at the beginning of curve (B.C.), or end of curve (E.C.).
5. Manhole spacing in curved runs shall not exceed 300-feet.
6. Minimum slopes shall be 50% greater than those given in paragraph 2.03A.
7. No reverse curves allowed between manholes.

G. SEWER DEPTH

The minimum depth to the invert of sewers is 7-feet with a maximum depth of 20-feet. Shallow sewers are subject to approval and may require additional protection such as special pipe, casing and/or a concrete cap. The Engineering Manager may require greater depths where it is required to extend sewers to serve other areas.

The separation of water and sewer lines must comply with the California Department of Public Health requirements.

H. SERVICE LATERALS

Each property occupied by a single-family dwelling shall have a 4-inch sewer service lateral installed at a minimum 2% grade from the main line sewer to the property line, maintained at a minimum of 5 ½-feet depth below the surface at the property line. Alternately, 6-inch service laterals may be laid on a 1% grade, maintained at a minimum of 5 ½-feet depth below the surface at the property line. For multiple-family dwellings, commercial lots, schools, etc., special consideration shall be given when determining the correct size. Lateral sizing for all special considerations shall be approved by the Engineering Manager.

A service lateral shall be installed for each property along a main line extension. A cleanout one foot inside of the property must be installed as shown on the Standard Details. Sewer lateral connections to the main can not be made within 5-feet of any other sewer connection, including laterals serving the other side of the street. Deep cut risers or chimneys shall not be used.

All service laterals shall be constructed perpendicular to the sewer main unless special considerations are approved by the Engineering Manager.

I. TV INSPECTION

All sewer lines shall be final inspected by TV camera. Video in DVD format shall be recorded in the presence of the Engineering Manager and presented to the Engineering Manager. The video shall show stationing and locations of all manholes and laterals. The Contractor shall bear all costs for the video inspection process. The Contractor shall use Wincan Program and provide two (2) hard copies and two (2) DVDs.

Any areas showing evidence of reverse slope as indicated by ponding water or dips in vertical pipe alignment, as well as any other defects shall be repaired to the satisfaction of the Engineering Manager at the Contractor's expense.

J. PLAN AND PROFILE

Show all underground Public utilities in both plan and profile, and provide minimum clearance per California Department of Public Health, Water Works Standards, latest revision.

K. SEWER NOTES

RMWD Sewer Notes shall be included in all sewer improvement plans. The notes are included in the RMWD Standard Drawings and are subject to revision by the Engineering Manager.

L. VERTICAL CLEARANCE

The minimum vertical distance between sewers and other utilities shall be 1-foot. Special design is required for sewer laterals or gravity mains over water lines. Force mains are not permitted over water lines.

M. CUT-OFF WALLS

In steep unpaved areas, pipe (and trench) shall be protected by cut-off walls per Standard Drawing S-10. Pipe anchors are required on all slopes 15% or greater.

N. CONNECTION OF COLLECTION LINES WITH DIFFERENT DIAMETERS

The crown elevations of connecting pipes shall be matched at manhole junctions.

O. MANHOLE LINING

Manholes with the following conditions shall be provided with polyurethane protective lining system and manhole odor control inserts:

1. All new manholes on sewers 18-inches or greater diameter.
2. All new manholes where entering pipe slope is 5% or greater.
3. All existing manholes with new connections.
4. All manholes within 1,000-feet of receiving a force main discharge.
5. All areas where ground water is present.

P. MANHOLE COVERS

All manhole covers shall be locking covers.

END OF SECTION 2

**TECHNICAL
SPECIFICATIONS**

SECTION 02223

TRENCHING, BACKFILLING, AND COMPACTING

PART 1 GENERAL

1.01 DESCRIPTION

This section includes materials, installation, and testing of trench excavation, backfilling, and compacting.

1.02 REFERENCE STANDARDS

The publications listed below form part of this specification to the extent referenced and are referred in the text by the basic designation only. Reference shall be made to the latest edition of said standards unless otherwise called for.

ASTM D1556	Standard Test Method for Density and Unit Weight of Soil in Place by the Sand-Cone Method
ASTM D2922	Standard Test Methods for Density of Soil and Soil-Aggregate in Place by Nuclear Methods (Shallow Depth)
ASTM D3017	Standard Test Method for Water Content of Soil and Rock in Place by Nuclear Methods (Shallow Depth)
ASTM D1557	Test Method for Laboratory Compaction Characteristics of Soil Using Modified Effort (56,000 ft-lbf/ft ³ (2,700 kN-m/m ³))
ASTM D4253	Standard Test Methods for Maximum Index Density and Unit Weight of Soils Using a Vibratory Table
ASTM D4254	Standard Test Methods for Minimum Index Density and Unit Weight of Soils and Calculation of Relative Density
ASTM D75	Standard Practice for Sampling Aggregates
ASTM C90	Standard Specification for Load bearing Concrete Masonry Units
ASTM A82	Standard Specification for Steel Wire, Plain, for Concrete Reinforcement

1.03 RELATED WORK SPECIFIED ELSEWHERE

RMWD Standards Manual

1.04 EARTHWORK AND REPAIRS IN CITY, COUNTY, AND STATE RIGHTS OF WAY

Conform to the requirements and provisions of the permits issued by those agencies in addition to the requirements of these Standard Specifications. If a permit is not required, earthwork and repairs shall conform to the standards of the agency in whose right of way the work is done in addition to the requirements of these Standard Specifications.

1.05 SAFETY PRECAUTIONS

Observe safety precautions in all phases of the work. Included shall be trench shoring, bracing, lighting, and barricades as dictated by reason and by the Safety Orders of the Division of Industrial Safety, State of California (CAL OSHA). Acquire an exemption letter or trenching permit from the California Division of Industrial Safety (CAL OSHA) and comply with Labor Code Section 6705,

Excavation Plans For Worker Protection. Submit a copy of the exemption letter or trenching permit with excavation drawings to the District prior to excavation work.

1.06 OBSTRUCTIONS

The Contractor's attention is directed to the possible existence of pipe and other underground improvements which may or may not be shown on the Drawings. Preserve and protect any such improvements whether shown on the Drawings or not. Expose such improvements in advance of the pipeline construction to allow for changes in the alignment as necessary. Where it is necessary to remove and replace or to relocate such improvements in order to prosecute the work, they shall be removed, maintained, and, permanently replaced by the Contractor at his expense. Relocation of said improvements shall not be performed without written permission of the owner of the utility. Existing underground utilities shall be protected in place.

1.07 SUBMITTALS

- A. Submit shop drawings in accordance with Section 1- General Conditions.
- B. Submit a report from a testing laboratory verifying that imported material is asbestos-free and conforms to the specified gradations or characteristics.
- C. Cal OSHA trenching permit or exemption letter.

1.08 TESTING FOR COMPACTION

- A. The District or the agency having jurisdiction over the area of the work will require the Contractor to provide a licensed soils engineer to test for compaction as described below.
- B. Determine the density of soil in place by the sand cone method, ASTM D1556 or by nuclear methods, ASTM D2922 and D3017.
- C. Determine laboratory moisture-density relations of soils by ASTM D1557.
- D. Determine the relative density of cohesion-less soils by ASTM D4253 and D4254.
- E. Sample backfill materials by ASTM D75.
- F. "Relative compaction" is the ratio, expressed as a percentage, of the in place dry density to the laboratory maximum dry density.
- G. Make excavation for compaction tests at the locations and to the depths designated by the soils engineer. Backfill and re-compact the excavations at completion of testing. When tests indicate that the compaction is less than the specified relative compaction, rework and retest those areas until the specified relative compaction has been obtained.

1.09 PIPE BEDDING

The pipe bedding shall be defined as a layer of material immediately below the bottom of the pipe and extending over the full trench width in which the pipe is bedded. Thickness of pipe bedding shall be a minimum of 6-inches compacted to 90% relative compaction.

1.10 PIPE ZONE

The pipe zone shall include the full width of trench from the bottom of the pipe to a horizontal level 12-inches above the top of the pipe. Where multiple pipes are placed in the same trench, the pipe zone shall extend from the bottom of the lowest pipe to a horizontal level above the top of the highest or topmost pipe. Thickness of pipe zone above the highest top of pipe shall be a minimum of 12-inches. No jetting within pipe zone.

1.11 TRENCH ZONE

The trench zone includes the portion of the trench from the top of the pipe zone to the bottom of the pavement zone or to the existing surface in unpaved areas. No jetting within trench zone.

1.12 UPPER ZONE

The upper zone includes the asphalt concrete and aggregate base pavement section placed over the trench backfill.

1.13 WATER FOR CONSTRUCTION

Water supplied by the District, for whatever needs and uses, shall be paid for in accordance with the rates and rules of the District. The only exception is by written agreement with the District.

PART 2 MATERIALS**2.01 NATIVE EARTH BACKFILL - TRENCH ZONE**

Native earth backfill used above the pipe zone shall be excavated fine grained materials or loose soil free of asbestos, organic matter, roots, debris, rocks larger than 4-inches in diameter, clods, clay balls, broken pavement, and other deleterious materials. Backfill material shall be so graded that at least 40% of the material passes a No. 4 sieve. The coarser materials shall be well distributed throughout the finer material. Backfill materials that are obtained from trench excavated materials to the extent such material is available, shall be screened at the discretion of the Engineering Manager during the trenching operation.

If screened during trenching, the material shall be maintained free of unscreened material during the handling and backfilling process. Hand selecting of rocks from earth as it is placed into the trench will not be permitted in lieu of the specified screening. Under no circumstances will native earth backfill be allowed or used in the pipe base area, pipe zone area, or directly under paved roads.

2.02 IMPORTED MATERIAL FOR BACKFILL - TRENCH ZONE

Imported material shall conform to that specified for native earth backfill or imported sand.

2.03 IMPORTED SAND - PIPE BEDDING AND PIPE ZONE

Imported sand used in the pipe base and pipe zone shall consist of natural or manufactured granular material, or a combination thereof, free of deleterious amounts of organic material, mica, loam, clay, and other substances. Under no circumstances will decomposed granite or native earth backfill be allowed or used in the pipe base or pipe zone areas. The material must have been tested to a minimum Sand Equivalent of 30 within two (2) weeks of its use. Imported sand shall have the following gradation or similar:

<u>Sieve Size</u>	Percent Passing	<u>By Weight</u>
		3/8-inch
No.4	75 - 100	
No.30	12 - 50	
No.100	5 - 20	
No.200	0 - 15	

2.04 ROCK REFILL FOR FOUNDATION STABILIZATION

Rock refill shall be crushed or natural rock having the following gradation:

<u>Sieve Size</u>	Percent Passing	<u>By Weight</u>
		3 inches
1-1/2 inches	70 - 100	
3/4-inch	60 - 100	
No.4	25 - 55	
No.30	10 - 30	
No.200	0 - 15	

2.05 GRANULAR MATERIAL FOR STRUCTURAL BACKFILL

A. Granular material for structural backfill shall be free of asbestos, organic materials, clay balls, and shall have the following gradation:

<u>Sieve Size</u>	Percent Passing	<u>By Weight</u>
		3/4-inch
1/2-inch	95 - 100	
3/8-inch	50 - 100	
No.4	20 - 65	
No.8	10 - 40	
No.40	0 - 20	
No.200	0 - 5	

B. Whenever the phrase "structural backfill material" is used in these Standard Specifications, it shall mean granular material for structural backfill as described above.

C. Excavated material may be used for structural backfill provided it conforms to the Standard Specifications for structural backfill material.

2.06 CONCRETE FOR BELOW GROUND INSTALLATIONS

A. Concrete for anchors, collars, encasements, supports, and thrust blocks shall be Class A for reinforced items and Class C for un-reinforced items per Specification Section 03300, except use rapid set concrete mix where indicated.

B. Provide anchor blocks at valves in pipe having rubber gasket bell and spigot or unrestrained mechanical joints.

C. Provide support blocks at all valves.

- D. Provide thrust or anchor blocks at all vertical or horizontal bends unless other restraint means are approved by the Engineering Manager.

2.07 TRENCH CUT-OFF WALLS

- A. Provide ASTM C 90, Grade N-I, hollow load-bearing concrete masonry units, medium weight, moisture controlled, average compressive strength over gross area of 1,000 psi. Nominal face dimensions: 8-inches by 8-inches by 16-inches.
- B. Provide ladder steel conforming to ASTM A82.
- C. Mortar and grout shall be a mixture of cement, sand, and water. Mortar shall consist of not more than one part cement to two and one-half parts sand by damp loose volume. The quantity of mixing water shall be no more than necessary for handling and placing.

2.08 WATER FOR COMPACTION

Water used in compaction shall have a maximum chloride concentration of 500 mg/l, a maximum sulfate concentration of 500 mg/l, and shall have a pH of 7.0 to 9.0. Water shall be free of acid, alkali, or organic materials injurious to the pipe or coatings. Salt water will not be allowed.

PART 3 EXECUTION

3.01 COMPACTION REQUIREMENTS

Unless otherwise shown on the Drawings, otherwise described in the Specifications, or required by the agency having jurisdiction over the area of the work, relative compaction in pipe trenches shall be a minimum as follows:

Pipe Bedding	90% relative compaction
Pipe Zone	90% relative compaction
Trench Zone	90% relative compaction
Upper Zone	95% relative compaction

3.02 SHEETING, SHORING, AND BRACING OF TRENCHES

Trenches shall have sheeting, shoring, and bracing conforming California Occupational and Health Administration (Cal-OSHA) - California Code of Regulations (CCR) Title 8, and the District's requirements.

3.03 SIDEWALK, PAVEMENT, AND CURB REMOVAL

Cut and remove bituminous and concrete pavements regardless of the thickness, and curbs and sidewalks, prior to excavation of trenches with a pavement saw, hydrohammer, or pneumatic pavement cutter. Width of the pavement cut shall be at least equal to the required width of the trench at ground surface. Haul pavement and concrete materials from the site. Do not use for trench backfill.

3.04 BLASTING

Blasting operations will not be allowed unless approved by the Engineering Manager.

3.05 DEWATERING

- A. Provide and maintain means and devices to remove and dispose of all water entering the trench excavation during the time the trench is being prepared for the pipelaying, during the laying of the pipe, until cement mortar of exterior joints has set hard, when concrete is being deposited and during the hydration process, and until the backfill at the pipe zone and trench zone has been completed. These provisions shall apply during the noon hour as well as overnight. Dispose of the water in a manner to prevent damage to adjacent property and in accordance with regulatory agency requirements. Do not drain trench water through the pipeline under construction.
- B. The contractor is responsible for meeting all Federal, State, County, and local laws, rules and regulations regarding the treatment and disposal of water from dewatering operations at the construction site.

3.06 MATERIAL REPLACEMENT

Remove and replace any trenching and backfilling material which does not meet the Specifications, at the Contractor's expense.

3.07 TRENCH WIDTHS

Pipe trench widths in the pipe zone will be limited as follows:

<u>Pipe Diameter</u>	<u>Minimum Trench Width</u>	<u>Maximum Trench Width</u>
4" through 12"	O.D. + 12"	O.D. + 16"
14" through 48"	O.D. + 16"	O.D. + 24"

Trench width at the top of the trench will not be limited except where width of excavation would undercut adjacent structures and footings. In such case, width of trench shall be such that there is at least 2 feet between the top edge of the trench and the structure or footing. Where shoring or encasement is required, trench widths shall be increased accordingly.

3.08 TRENCH EXCAVATION

- A. Perform all excavation regardless of the type, nature, or condition of the material encountered to accomplish the construction. Do not operate excavation equipment within 5 feet of existing structures or newly completed construction. Excavate with hand tools in these areas.
- B. Excavate the trench to the lines and grades shown on the Drawings with allowance for pipe thickness, sheeting and shoring if used, and for pipe base. If the trench is excavated below the required subgrade, refill any part of the trench excavated below the subgrade at no additional cost to the District with imported sand. Place the refilling material over the full width of trench in compacted layers not exceeding 6-inches deep to the established grade with allowance for the pipe base.
- C. Trench depth shall accommodate the pipe and the pipe base at the elevations shown in the profile on the Drawings. No pipe shall be installed without a designed profile unless approved by the Engineering Manager.
- D. Construct trenches in rock by removing rock to a minimum of 6-inches below bottom of pipe and backfilling with imported sand.

3.09 LOCATION OF EXCAVATED MATERIAL

During trench excavation, place the excavated material only within the working area or within the areas shown on the Drawings. Do not obstruct any roadways or streets. Conform to federal, state, and local codes governing the safe loading of trenches with excavated material.

3.10 LENGTH OF OPEN TRENCH

- A. The total length of open trench shall not exceed 600 feet including excavation, pipeline installation and backfill in any one location.
- B. Where pipelines are located beneath or adjacent to existing paved roads, backfill all trenches at the end of each workday and place temporary or first layer of paving. Clean all new and adjacent existing paved surfaces of residual excavated and backfill materials. Perform dust control operations in these areas with a vacuum type mobile street sweeper. No open trenches will be allowed in these areas.
- C. Provide ingress and egress to buildings and property at all times. Provide steel covering for vehicular access in accordance with the County of San Diego Public Works requirements.

3.11 FOUNDATION STABILIZATION

After the required excavation has been completed, the Engineering Manager will inspect the exposed subgrade to determine the need for any additional excavation. It is the intent that additional excavation be conducted in all areas within the influence of the pipeline where unacceptable materials such as soft, spongy or deleterious materials exist at the exposed grade. Over excavation shall include the removal of all such unacceptable material that exists directly beneath the pipeline to a minimum width equal to the maximum trench width and to a depth determined by the Engineering Manager. Backfill the trench to the established subgrade of the pipe base with rock refill material for foundation stabilization. Place the foundation stabilization material over the full width of the trench and compact in layers not exceeding 6-inches deep to the required grade. Place imported sand on the compacted foundation stabilization and apply water to wash the sand into the voids of the rock refill material. Continue this procedure until the voids of the rock refill have been filled with imported sand. Do not apply water in such quantities that it will damage the integrity of the pipeline or other improvements.

3.12 CONCRETE FOR BELOW GROUND INSTALLATIONS

Encase pipe with concrete to the line and dimensions indicated or place concrete between the undisturbed ground and the pipe or fittings to be restrained or supported. Quantity or bearing area of the concrete against undisturbed ground shall be as shown on the Standard Drawings, Drawings, or as directed by the Engineering Manager. Provide temporary support on the pipe, fittings, or valves until the concrete has obtained a 3-day cure. Place concrete such that the pipe joints, fittings, or valves are accessible for repairs. Spade or rod the concrete during placement to eliminate honeycombing. Backfilling of the trench adjacent to the concrete will not be allowed until the concrete has cured for at least 3 days. Allow concrete to cure for at least 7 days prior to subjecting the concrete to pipeline pressure. Where rapid set concrete mix has been used, the 3-day and 7-day cure time is not required. Backfill the rapid set concrete mix as soon as the concrete is hard (approximately one to two hours) and place pipeline into service.

3.13 TRENCH CUT -OFF WALLS

Install trench cut-off walls at the locations shown on the Drawings, and at 20 feet on center on slopes 30% and steeper and with the District's consultation slopes steeper than 50%. Hand cut trench walls to form a neat slot into which the concrete blocks can be laid as tight as possible to the downhill side.

Place concrete blocks in horizontal layers and reinforce with ladder steel as the wall is laid. Lay blocks full-bedded in mortar to prevent leakage of grout. All head joints shall be solidly filled with mortar. Cut blocks to fit around the pipe and mortar in place. Provide weep holes in the wall to relieve hydrostatic pressure. Provide one 1/2-inch diameter weep hole for each 1.5 square foot of wall in the trench pipe zone. Grout solid all cells of the wall. Place backfill in layers being evenly brought up on each side of the cut-off wall. Compact by hand tamping. Give special attention to placing backfill in slot in trench walls.

3.14 TRENCH BACKFILLING

- A. Place the specified thickness of pipe bedding material over the full width of trench and compact to the specified relative compaction. Grade the top of the pipe base ahead of the pipelaying to provide firm, continuous, uniform support along the full length of the trench for the pipe, fittings, and valves.
- B. Excavate bell holes at each joint to permit proper assembly and inspection of the entire joint. Fill and compact the area excavated for the joints with the pipe base material.
- C. After the pipeline has been bedded and the cement mortar used in the exterior joints has set hard, place pipe zone material simultaneously on both sides of the pipe, fittings, and valves, keeping the level of backfill the same on each side. Carefully place the material around the pipe so that the pipe barrel is completely supported and that no voids or un-compacted areas are left beneath the pipe. Use particular care in placing material on the underside of the pipe to prevent lateral movement during subsequent backfilling. Do not drop sharp, heavy pieces of material directly onto the pipe or the tamped material around the pipe.
- D. Compact material in the pipe zone by hand tamping only. Care shall be exercised in backfilling to avoid damage to pipe coatings and polyethylene encasement.
- E. Push the native earth backfill or imported material for backfill carefully onto the imported sand previously placed in the pipe zone. Do not permit free fall of the material until at least 2 feet of cover is provided over the top of the pipe. Compact backfill material in the trench zone to the specified relative compaction by mechanical compaction or hand tamping.
- F. Place and compact pipe zone material in layers not exceeding 12-inches of compacted thickness. Place and compact native earth or imported material for backfill in the middle zone in layers not exceeding 6-inches of compacted thickness.

3.15 MECHANICAL COMPACTION OR HAND TAMPING

Place imported sand and backfill materials, per Part 2, in uniform layers of the indicated thickness. Compact each layer to the required minimum relative compaction at the optimum moisture content. Do not use heavy duty compaction equipment with an overall weight in excess of 125 pounds until backfill has been completed to a depth of 2 feet over the top of pipe. Do not use high impact hammer type equipment except where the pipe manufacturer warrants in writing that such use will not damage the pipe.

3.16 DISPOSAL OF EXCESS EXCAVATED MATERIAL

Dispose of excess excavated material offsite. Contractor shall make his own arrangements for the disposal of the excess material and bear all costs incidental to such disposal.

3.17 TRENCHING RESURFACING

- A. Thickness of asphalt concrete resurfacing shall be 1-inch greater than the depth of the existing asphalt or a minimum of 3-inches which ever is greater.
- B. Base material shall be replaced to the depth of the existing base or a minimum of 6-inches which ever is greater.
- C. Trench resurfacing shall be done in accordance with RMWD Standard Drawings W-21 and S-15.

3.18 FINAL CLEAN-UP

- A. After backfilling, grade the right-of-way to the contours of the original ground and match the adjacent undisturbed ground. Make surfaces free of all cleared vegetation, rubbish and other construction wastes. Dispose of all excavated or surface rocks and lumps which cannot be readily covered by spreading. On slopes 15% and steeper or where rainfall would create an erosion problem as determined by the Engineering Manager, provide cut off walls per RMWD Standard Drawing.
- B. Replace street improvements in kind, such as curbs and gutters, monuments, barricades, traffic islands, signalization, fences, signs, mail boxes, etcetera that are cut, removed, damaged, or otherwise disturbed by the construction.

3.19 SLOPE PROTECTION

- A. Install slope protection as required by the agency of jurisdiction. Prepare and seed all open ground within the easement or working area disturbed by the construction, not otherwise protected from erosion, or as determined by the Engineering Manager. After final clean-up, cultivate areas to be seeded to break up any compaction resulting from grading operations.
- B. Cover areas to be seeded with a mulch of rice, wheat, oats, or barley straw spread uniformly at the rate of 2 tons per acre for new straw. If stable bedding straw is used, spread uniformly at the rate of 3 tons per acre. Roll straw with stud roller to produce a uniform ground surface, incorporating the straw into the soil so as not to support combustion or to be blown from the area by winds. Seed the mulched areas with a mixture of 32 pounds of barley and 32 pounds of western rye grass seed per acre. Seed shall be 95% pure and have a minimum of 85% germination.
- C. Unimproved areas disturbed during construction of the pipeline or appurtenances may be hydro seeded at the Engineering Manager's discretion. An example of a seed mixture list for coastal sage scrub re-vegetation is as follows:

BOTANICAL NAME	COMMON NAME	lbs/acre
Eriogonum Fasciculatum	Flat-Top Buckwheat	2.0
Artemisia Californica	California Sagebrush	8.0
Lotus Scoparius	Deerweed	5.0
Salvia Apiana	White Sage	1.0
Eriophyllum Confertiflorum	Golden Yarrow	2.0
Yucca Whipplei	Our Lord's Candle	0.5
Vulpia Muralis 'Zorro'	Zorro Fescue	8.0
Plantago (Insularis) Ovata	Plantain	3.0
Eschscholzia Californica	California Poppy	3.0
Lupinus Hirsutissimus	Stinging Lupine	3.0
Phacelia Parryi	Bluebells	1.0

D. The hydro seed mix shall be a bonded matrix consisting of wood fiber, fertilize and high quality live seed in the following proportions:

SEED	SEE ABOVE
Fiber Mulch	2,000 lbs/acre
Slow Release Fertilizer	150 lbs/acre
Soil Binder(Mix soil Binder at the rate of 1-lb per 25 gals)	100 lbs/acre

END OF SECTION 02223

SECTION 03250
CONCRETE ANCHORS

PART 1 - GENERAL

1.01 SUMMARY

This section includes the requirements for the use and installation of concrete anchors.

1.02 REFERENCES

- A. The publications and standards referenced herein form a part of this Specification.
- B. Where a date is given for reference standards, that edition shall be used. Where no date is given for reference standards, the latest edition shall be used.

1.03 SUBMITTALS

- A. Submittals shall be made in accordance with Section 1 - General Conditions and the following special provisions provided herein.
- B. Product Data: The Contractor shall submit manufacturer's standard catalog data sheets.
- C. Material Safety Data Sheets: The Contractor shall submit Material Safety Data Sheets (MSDS) for each proposed product.
- D. Test Reports and Certifications: The Contractor shall submit a manufacturer's certification verifying conformance to these Specifications and that all products in contact with potable water are NSF approved.
- E. Manufacturer's Instructions: Manufacturer's printed instructions for shipping, storing, mixing and application and the applicable ICC report shall be submitted prior to delivery of the product.
- F. Installation Instructions: Manufacturer's printed instructions for all phases of installation including hole size, preparation, placement, and procedures. Specific instruction for safe handling and installation of all concrete anchors to personnel handling and installing concrete anchors.

1.04 QUALITY ASSURANCE

- A. Manufacturer's Service for Adhesive Anchors:
 - 1. Jobsite training of Contractor's personnel shall be conducted for safe and proper installation, handling, and storage of adhesive system.
 - 2. Training shall be scheduled with Contractor, and the Engineering Manager shall be notified of time and place for sessions.

1.05 DELIVERY, STORAGE AND HANDLING

- A. Materials shall be delivered in sealed containers with labels legible and intact. Each container shall be clearly marked with the following information:
 - 1. Name of manufacturer
 - 2. Manufacturer's product identification
 - 3. Manufacturer's instructions for mixing, installation, and application
 - 4. Warning for handling and toxicity
 - 5. Manufacturer's batch numbers
- B. Materials shall be stored at temperatures between 40°F and 100°F unless specifically stipulated otherwise by the manufacturer.
- C. Materials shall be handled safely and in a manner that will avoid breaking container seals.
- D. The Contractor shall store adhesive components as recommended by the manufacturer and approved by Engineering Manager, and shall store and handle adhesive components in accordance with the requirements of the International Fire Code (IFC), local fire marshal, and all health, safety, and environmental regulations.

PART 2 PRODUCTS

2.01 GENERAL

- A. Stainless steel anchors shall be used in all applications shown on the Drawings and in all cases where concrete anchors will be intermittently or continuously in contact with water or in a moist environment whether or not shown on the Drawings.
- B. Stainless steel studs, bolts, nuts, and washers shall be stamped indicating the type of stainless steel.
- C. Concrete anchors shall be stainless steel, unless noted otherwise on the Drawings. Galvanized concrete anchors shall be used where stainless steel anchors are not specified on the Drawings or required based on exposure requirements noted above.

2.02 CONCRETE ADHESIVE ANCHORS

- A. Concrete adhesive anchors shall be Type 316 stainless steel studs, bolts, nuts, and washers. After anchor stud installation and prior to assembly, all threaded portions of stainless steel bolts, studs, and cap screws shall be coated with an NSF-certified thread lubricant. Lubricant shall be as specified in Specification Section 05500, Miscellaneous Metalwork.
- B. Adhesive for anchorage and doweling in hardened concrete shall be 2-component,

insensitive to moisture, and be designed for installation in adverse environments.

- C. Adhesive anchors shall be preproportioned adhesive system or an adhesive capsule system.
- D. Stainless steel fasteners shall conform to the requirements of ASTM A193, Grade B8MA or B8MNA Type 316 or 316N.
- E. Studs shall be Type 316 stainless steel threaded rod free of grease, oil, or other deleterious material with 45° chisel point.
- F. The cure temperature, pot life, and workability of adhesive shall be compatible for intended use and anticipated environmental conditions.
- G. Acceptable Products:
 - 1. Hilti, Inc., HIT HY-150 Adhesive Anchor System (ICC ER-5193),
 - 2. ITW Ramset/Redhead Epcon System, Ceramic 6 Epoxy Anchors (ICC ER-4285),
 - 3. Or approved equal.

2.03 CONCRETE EXPANSION ANCHORS

- A. Concrete expansion anchors shall be used where specifically stated on the Drawings.
- B. Expansion anchors are used for the installation of comparatively light metal accessories that are not required to be installed before the concrete is placed. Expansion anchors will not be permitted in applications that will be subjected to vibrations or impact loads.
- C. Expansion anchor body, nut, washer, and expansion sleeve shall be Type 304 or Type 316 stainless steel. All threaded portions of stainless steel anchors shall be coated with an NSF-certified thread lubricant. Lubricant shall be as specified in Specification Section 05500, Miscellaneous Metalwork.
- D. Acceptable Products:
 - 1. Hilti, Inc., Kwik Bolt TZ Anchors in Concrete (ICC ESR-1917),
 - 2. Hilti, Inc., Kwik Bolt 3 Concrete Anchor
 - 3. ITW Red Head, Trubolt Wedge Anchors in Concrete (ICC ESR-2251),
 - 4. ITW Ramset/Redhead, Dynabolt Sleeve Anchor
 - 5. Simpson Strong-Tie Company, Inc., Strong-Bolt Wedge Anchor (ICC ESR1771)
 - 6. Simpson Strong-Tie company Inc., Anchor Systems, Sleeve-All Sleeve Anchors
 - 7. Or approved equal.

2.04 CONCRETE SCREW ANCHORS

- A. Concrete screw anchors shall be used where specified on the Drawings.
- B. Screw anchor shall be Type 410 stainless steel.

C. Acceptable Products:

1. Hilti, Inc., Kwik Con II Concrete Screw Anchor (ICBO ER-5259),
2. Or approved equal.

PART 3 EXECUTION

3.01 GENERAL

- A. **Dispensing, Metering, or Mixing Adhesive Components:** The Contractor shall use portable, automatic metering and mixing device or machine capable of maintaining prescribed mix ratio within deviation of 5% or less, by volume. Dispensing equipment shall be as recommended by the manufacturer and approved by Engineering Manager.
- B. The Contractor shall install anchors in accordance with the manufacturer's printed recommendations and the applicable ICC report.
- C. The Contractor shall dispense components through a specially designed static mixing nozzle that thoroughly mixes components and places mixed components at base of predrilled hole.
- D. Mixing nozzles shall have non-removable internal static mixer required to ensure proper blending of components.

3.02 PREPARATION OF CONCRETE SURFACES

- A. Concrete surfaces shall be prepared in accordance with the requirements of the applicable ICC report and the manufacturer's written recommendations.
- B. Holes for all studs shall be accurately located and drilled by using templates and drilling jigs.
- C. **Drilling Equipment:**
 1. Drilling hammers for holes shall be electric or pneumatic rotary type with medium or light impact.
 2. The Contractor shall use drill bit diameter meeting ICC report requirements.
 3. Hollow drills shall be provided with flushing air systems.
 4. Where edge distances are less than 2 inches, the Contractor shall use lighter impact equipment to prevent micro cracking and concrete spalling during drilling process.
 5. **Obstructions in Drill Path:**
 - a. When existing reinforcing steel is encountered during drilling and when approved by the Engineering Manager, the Contractor shall enlarge the hole by 1/8-inch, core through the existing reinforcing steel at the larger

diameter, and resume drilling at original hole diameter.

- b. Misdrilled holes shall be filled with adhesive, as specified in this Section, so as not to entrap or create air pockets.
6. Holes shall be made free of dust and loose materials by the use of moisture free and clean compressed air or other acceptable and approved means.
 7. Anchor embedment depth and spacing shall be as shown on the Drawings.

3.03 INSTALLATION

- A. Concrete anchors shall be installed in accordance with the manufacturer's printed recommendations and the requirements of the applicable ICC Report. Manufacturer's recommended drills and equipment shall be used. Hole diameter is critical to installation; only drills recommended by the anchor manufacturer shall be used.
- B. Concrete anchors shall not be installed until concrete has attained the minimum design compression strength.
- C. Anchor shall be dry and grease-free.
- D. Turn and agitate anchor immediately following placement to ensure the absence of voids and to ensure that adhesive makes contact with all surfaces.
- E. An anchor shall not be installed closer than 6 times its diameter to either an edge of concrete or 12 times its diameter to another anchor, unless specifically shown on the Drawings.
- F. Adhesive anchoring system shall not be used when temperature of concrete is outside the ranges recommended by the manufacturer.
- G. Specific manufacturer safe handling practices shall be followed when handling and/or installing all concrete anchors.
- H. Concrete shall be dry at the time of adhesive anchor placement.
- I. Concrete adhesive anchors installation torque shall be in accordance with the provisions stated on the Drawings. In no case shall the torque exceed the manufacturer's installation recommendations.
- J. Concrete expansion anchors installation torque shall be in accordance with the manufacturer's installation recommendations.
- K. Concrete screw anchors shall be installed in accordance with the manufacturer's installation recommendations.

3.04 CURING

Adhesive materials shall be protected from temperature extremes during curing. The temperature of the base materials shall not exceed the range permitted.

3.05 FIELD QUALITY CONTROL

- A. The Engineering Manager will inspect concrete surfaces prior to application.
- B. The Contractor shall engage the services of a testing agency to provide special inspection services where required by applicable ICC product evaluation reports. Special inspection personnel shall be certified for the specific application.
- C. Moisture content for concrete shall be evaluated by determining if moisture will collect at bond lines between old concrete and adhesive before adhesive has cured. This shall be accomplished by taping a 4-foot by 4-foot polyethylene sheet to concrete surface in accordance with the requirements of ASTM D4263. If moisture collects on underside of polyethylene sheet before adhesive curing time has elapsed, then concrete shall be allowed to dry and the test shall be repeated until results show no moisture.
- D. Concrete adhesive materials will be sampled in the field and tested for conformance with the Specifications. At least one sample will be taken from each shipment or production lot.

3.06 CLEANUP

- A. Concrete surfaces beyond the limits of the adhesive shall be protected against spillage.
- B. Adhesive applied or spilled beyond desired areas shall be immediately removed. Cleanup shall be performed with material designated by the adhesive manufacturer.

END OF SECTION 03250

SECTION 03300

CAST-IN-PLACE CONCRETE

PART 1 GENERAL

1.01 DESCRIPTION

This section describes materials and methods for formwork, reinforcement, mixing, placement, curing and repairs of concrete, and the use of cementations materials and other related products. This section includes concrete, mortar, grout, reinforcement, thrust and anchor blocks, valve support blocks and manhole bases.

1.02 REFERENCE STANDARDS

The publications listed below form part of this specification to the extent referenced and are referred to in the text by the basic designation only. Reference shall be made to the latest edition of said standards unless otherwise called for.

ASTM A185	Specification for Steel Welded Wire Fabric, Plain, for Concrete Reinforcement
ASTM A615 / A615M	Specification for Deformed and Plain Billet-Steel Bars for Concrete Reinforcement
ASTM C150	Specification for Portland Cement
ASTM C494	Specification for Chemical Admixtures for Concrete
ASTM C881	Specification for Epoxy-Resin-Base Bonding Systems for Concrete
CRSI	Recommended Practice for Placing Reinforcing Bars
SSPWC	Standard Specifications for Public Works Construction "Greenbook" (Current Version)

1.03 RELATED WORK SPECIFIED ELSEWHERE

RMWD	Standards Manual
Section 02223	Trenching, Backfilling and Compacting
Section 03461	Precast Concrete Manholes

1.04 APPLICATIONS

The following materials, referenced in other sections, shall be provided and installed in accordance with this specification for the applications noted below:

- A. Concrete for thrust and anchor blocks for horizontal and vertical bends, ductile-iron or steel fittings, fire hydrant bury ells, and support blocks for valves 4-inch and larger, all in accordance with the Standard Drawings.
- B. Concrete for collars, cradles, curbs, encasements, gutters, manhole bases, protection posts, sidewalks, splash pads, and other miscellaneous cast-in-place items.

- C. Mortar for filling and finishing the joints between manhole and vault sections and setting manhole grade rings and cover frames. Mortar may also be used for repairs of minor surface defects of no more than 1/4-inch in depth or 1/2-inch in width on non-structural, cast-in-place items such as splash pads or concrete rings around manholes. (Note that large voids, structural concrete and pipe penetrations into vaults shall be repaired with non-shrink grout; repairs to precast manholes and vaults and cast-in-place manhole bases shall be repaired with an epoxy bonding agent and repair mortar, as outlined below.)
- D. Epoxy bonding agent for bonding repair mortar to concrete on repairs to damaged surfaces of precast or cast-in-place concrete manholes and vaults.
- E. Repair mortar for repair to damaged surfaces of precast or cast-in-place concrete manholes and vaults. An epoxy bonding agent shall be used in conjunction with repair mortar.
- F. Non-shrink grout for general purpose repair of large construction voids, pipe penetrations into vaults and grouting of base plates for equipment or structural members.
- G. Epoxy adhesives for grouting of anchor bolts.
- H. Protective epoxy coating for application to reinforcing steel within existing concrete structures exposed during construction.
- I. Damp-proofing for application to the exterior surfaces of concrete manholes and vaults located at or below the water table or where showing evidence of moisture or seepage, and as directed by the Engineering Manager.
- J. New construction and repairs use Con Shield MS-10,000 with Con mic Shield.

1.05 DELIVERY, STORAGE AND HANDLING

Deliver reinforcing steel to the site bundled and tagged with identification. Store on skids to keep bars clean and free of mud and debris. If contaminated, all bars shall be cleaned by wire brushing, sand blasting, or other means prior to being set in forms.

PART 2 MATERIALS

2.01 CONCRETE

- A. All Portland cement concrete shall conform to the provisions of Sections 201, 202 and 303 of the Standard Specifications for Public Work Construction (Greenbook).
- B. Class 560-C-3250 concrete, as described in the Greenbook, Section 201, shall be used for all applications unless otherwise directed by the Engineering Manager. The maximum water/cement ratio shall be 0.53 by weight, and the maximum slump shall be 4-inch.
- C. In certain circumstances, rapid-setting concrete may be required. Accelerating admixtures shall conform to ASTM C494 and may be used in the concrete mix as permitted by the Engineering Manager. Calcium chloride shall not be used in concrete.

- D. Where concrete is needed to resist microbial induced corrosion of sewer structures an antimicrobial agent, Con^{MIC} Shield®, or approved equal, shall be used to render the concrete uninhabitable for bacterial growth. The liquid antibacterial additive shall be an EPA registered material and the registration number shall be submitted for approval prior to use in the project. The amount to be used shall be as recommended by the manufacturer of the antibacterial additive. This amount shall be included in the total water content of the concrete mix design. The additive shall be added into the concrete mix water to insure even distribution of the additive throughout the concrete mixture. A letter of certification must be submitted stating that the correct amount and correct mixing procedure was followed of all antimicrobial concrete.

2.02 REINFORCING STEEL

- A. Reinforcing steel shall conform to ASTM A615, Grade 60.
- B. Fabricate reinforcing steel in accordance with the current edition of the Manual of Standard Practice, published by the Concrete Reinforcing Steel Institute.

2.03 WELDED WIRE FABRIC

Welded wire fabric shall conform to ASTM A185.

2.04 TIE WIRE

Tie wire shall be 16-gage minimum, black, soft annealed.

2.05 BAR SUPPORTS

Bar supports in beams and slabs exposed to view after removal of forms shall be galvanized or plastic coated. Use concrete supports for reinforcing in concrete placed on grade.

2.06 FORMS

- A. Forms shall be accurately constructed of clean lumber. The surface of forms against which concrete is placed shall be smooth and free from irregularities, dents, sags or holes.
- B. Metal form systems may be used upon approval from the Engineering Manager. Include manufacturer's data for materials and installation with the request to use a metal form system.

2.07 MORTAR

Cement mortar shall consist of a mixture of Portland cement, sand and water. One (1) part cement and two (2) parts sand shall first be combined, and then thoroughly mixed with the required amount of water.

2.08 EPOXY BONDING AGENT

The epoxy bonding agent shall be an epoxy-resin-based product intended for bonding new mortar to hardened concrete and shall conform to ASTM C881. The bonding agent shall be selected from the Approved Materials List.

2.09 REPAIR MORTAR

Repair mortar shall be a two-component, cement-based product specifically designed for structurally repairing damaged concrete surfaces. The repair mortar shall exhibit the properties of high compressive and bond strengths and low shrinkage. A medium-slump repair mortar shall be used on horizontal surfaces, and a non-sag, low-slump repair mortar shall be used on vertical or overhead surfaces. Repair mortar shall be selected from the Approved Materials List.

2.10 NON-SHRINK GROUT

Non-shrink grout shall be a non-metallic cement-based product intended for filling general construction voids or grouting of base plates for equipment or structural members. The non-shrink grout shall exhibit the properties of high compressive and bond strengths and zero shrinkage, and shall be capable of mixing to a variable viscosity ranging from a dry pack to a fluid consistency as required for the application. The non-shrink grout shall be selected from the Approved Materials List.

2.11 EPOXY ADHESIVE

Epoxy adhesive shall be a high-modulus epoxy-resin-based product intended for structural grouting of anchor bolts and dowels to concrete. The epoxy adhesives shall conform to ASTM C881. A pourable, medium-viscosity epoxy shall be used on horizontal surfaces, and a heavy-bodied, non-sag epoxy gel shall be used on vertical surfaces. The epoxy adhesives shall be selected from the Approved Materials List.

2.12 PROTECTIVE EPOXY COATING

The protective epoxy coating shall be an epoxy-resin-based product exhibiting high bond strength to steel and concrete surfaces, and shall conform to ASTM C881. The protective epoxy coating shall be selected from the Approved Materials List.

2.13 DAMP-PROOFING FOR CONCRETE STRUCTURES

Damp-proofing material shall consist of two (2) coats of a single-component self-priming, heavy-duty cold-applied coal tar selected from the Approved Materials List.

PART 3 EXECUTION

3.01 FORMWORK

- A. The Contractor shall notify the Engineering Manager a minimum of one (1) working day in advance of intended placement of concrete to enable the Engineering Manager to check the form lines, grades, and other required items before placement of concrete.
- B. The form surfaces shall be cleaned and coated with VOL compliant form release oil prior to installation. The form surfaces shall leave uniform form marks conforming to the general lines of the structure.
- C. The forms shall be braced to provide sufficient strength and rigidity to hold the concrete and to withstand the necessary fluid pressure and consolidation pressures without deflection from the prescribed lines.

- D. Unless otherwise indicated on the plans, all exposed sharp concrete edges shall be 1/4-inch chamfered.

3.02 REINFORCEMENT

- A. Place reinforcing steel in accordance with the current edition of Recommended Practice for Placing Reinforcing Bars, published by the Concrete Reinforcing Steel Institute.
- B. All reinforcing steel shall be of the required sizes and shapes and placed where shown on the drawings or as directed by the Engineering Manager.
- C. Do not straighten or re-bend reinforcing steel in a manner that will damage the material. Do not use bars with bends not shown on the drawings. All steel shall be cold bent – do not use heat.
- D. All bars shall be free from rust, scale, oil, or any other coating that would reduce or destroy the bond between concrete and steel.
- E. Position reinforcing steel in accordance with the Approved Plans and secure by using annealed wire ties or clips at intersections and support by concrete or metal supports, spacers, or metal hangers. Do not place metal clips or supports in contact with the forms. Bend tie wires away from the forms in order to provide the concrete coverage equal to that required of the bars. If required by the Engineering Manager, the Contractor shall install bars additional to those shown on the drawings for the purpose of securing reinforcement in position.
- F. Place reinforcement a minimum of 2-inch clear of any metal pipe, fittings, or exposed surfaces.
- G. The reinforcement shall be so secured in position that it will not be displaced during the placement of concrete.
- H. All reinforcing steel, wire mesh, and tie wire shall be completely encased in concrete.
- I. Reinforcing steel shall not be welded unless specifically required by the Approved Plans or otherwise directed by the Engineering Manager.
- J. Secure reinforcing dowels in place prior to placing concrete. Do not press dowels into the concrete after the concrete has been placed.
- K. Minimum lap for all reinforcement shall be 40 bar diameters unless otherwise specified on the Approved Plans.
- L. Place additional reinforcement around pipe penetrations or openings 6-inch diameter or larger. Replace cut bars with a minimum of 1/2 of the number of cut bars at each side of the opening, each face, each way, same size. Lap with the uncut bars a minimum of 40 bar diameters past the opening dimension. Place one (1) same size diagonal bar at the four (4) diagonals of the opening at 45° to the cut bars, each face. Extend each diagonal bar a minimum of 40 bar diameters past the opening dimension.
- M. Wire mesh reinforcement is to be rolled flat before being placed in the form. Support and tie wire mesh to prevent movement during concrete placement.

- N. Extend welded wire fabric to within 2-inch of the edges of slabs. Lap splices at least 1-1/2 courses of the fabric and a minimum of 6-inch. Tie laps and splices securely at ends and at least every 24-inch with 16-gage black annealed steel wire. Pull the fabric into position as the concrete is placed by means of hooks, and work concrete under the steel to ensure that it is at the proper distance above the bottom of the slab.

3.03 EMBEDDED ITEMS

All embedded items, including bolts, dowels and anchors, shall be held correctly in place in the forms before concrete is placed.

3.04 MORTAR MIXING

The quantity of water to be used in the preparation of mortar shall be only that required to produce a mixture sufficiently workable for the purpose intended. Mortar shall be used as soon as possible after mixing and shall show no visible sign of setting prior to use. Re-mixing of mortar by the addition of water after signs of setting are evident shall not be permitted.

3.05 MIXING AND PLACING CONCRETE

- A. All concrete shall be placed in forms before taking its initial set.
- B. No concrete shall be placed in water except with permission of the Engineering Manager.
- C. As the concrete is placed in forms, or in rough excavations (i.e., thrust or anchor blocks), it shall be thoroughly settled and compacted throughout the entire layer by internal vibration and tamping bars.
- D. All existing concrete surfaces upon which or against which new concrete is to be placed shall be roughened, thoroughly cleaned, wetted, and grouted before the new concrete is deposited.

3.06 CONCRETE FINISHING

- A. Immediately upon the removal of forms, voids shall be neatly filled with cement mortar, non-shrink grout, or epoxy bonding agent and repair mortar as required for the application and as directed by the Engineering Manager.
- B. The surfaces of concrete exposed to view shall be smooth and free from projections or depressions.
- C. Exposed surfaces of concrete not placed against forms, such as horizontal or sloping surfaces, shall be Screeded to a uniform surface, steel-troweled to density the surface, and finished to a light broom finish.

3.07 PROTECTION AND CURING OF CONCRETE

The Contractor shall protect all concrete against damage. Exposed surfaces of new concrete shall be protected from the direct rays of the sun by covering them with plastic film wrap and by keeping them damp for at least 7 days after the concrete has been placed, or by using an approved curing

process. Exposed surfaces shall be protected from frost by covering with tarps for at least 5 days after placing.

3.08 REPAIRS TO DAMAGED CONCRETE SURFACES

Minor surface damage to hardened cast-in-place or precast concrete may be repaired, at the discretion of the Engineering Manager, using the specified materials in accordance with the manufacturer's recommendations and the following procedures:

- A. Cast-in-place or precast concrete for manholes and vaults: Remove loose or deteriorated concrete to expose a fractured aggregate surface with an edge cut to a ninety degree angle to the existing surface. Clean all debris from the area, apply a 20 mil coat of epoxy bonding agent to the prepared surface, and place repair mortar while the epoxy is still wet and tacky. On horizontal surfaces, for repair depths greater than 2-inch, add aggregate to the repair mortar as recommended by the manufacturer. On vertical or overhead surfaces, for repair depths greater than 2-inch, apply the repair mortar in successive lifts, scarifying the lifts, allowing them to harden, and applying a scrub coat of the material prior to proceeding with the next lift. Cure the material as for concrete in accordance with this specification.
- B. General Purpose: Remove loose and deteriorated concrete by mechanical means, sandblasting or high-pressure water blasting. Clean all debris from the area and apply non-shrink grout in a 1/4-inch minimum thickness, at the desired consistency, ranging from a dry pack, to a fluid-poured into a formed area, according to the application. Cure the material as for concrete in accordance with this specification.

3.09 EPOXY ADHESIVES FOR ANCHOR BOLT INSTALLATION

Anchor bolts grouted in place with an epoxy adhesive shall be installed using the specified materials in accordance with the manufacturer's recommendations and the following general procedures: Drill the hole with a rotary percussion drill to produce a rough, unpolished hole surface. The hole shall be sized to the manufacturer's recommendations and shall be approximately 1/4-inch wider than the diameter of the bolt, with a depth equal to 10 to 15 times the bolt diameter. Remove debris and dust with a stiff bristle brush and clean using compressed air. Utilizing a medium-viscosity epoxy for horizontal surfaces, and a gel-type non-sag epoxy for vertical surfaces, apply the material to fill the hole to approximately half its depth. Insert the bolt, forcing it down until the required embedment depth and projection length are attained and then twist the bolt to establish a bond. Secure the bolt firmly in place in the permanent position until the epoxy sets.

3.10 PROTECTIVE EPOXY COATING

Following core drilling at existing concrete structures, clean the exposed concrete surface and ends of reinforcing steel and apply two (2) coats of protective epoxy coating for a total dry film thickness of 10-15 mils. Allow the material to cure between coats and prior to continuing the installation through the penetration.

3.11 DAMP-PROOFING THE EXTERIOR OF CONCRETE STRUCTURES

Following completion of the exterior surfaces of manholes and vaults, including necessary repairs and piping penetrations into the structure, apply the specified material to prepared concrete surfaces in accordance with the manufacturer's recommendations. The surfaces to be coated shall be fully cured and free of laitance and contamination. The material shall be applied to all exterior surfaces below a point 12-inch above the water table or indications of seepage or moisture as

directed by the Engineering Manager. Apply two 15 mil coats, curing between coats, prior to backfill and/or immersion in accordance with the manufacturer's recommendations.

3.12 THRUST AND ANCHOR BLOCKS

Concrete thrust and anchor blocks shall be placed against wetted, undisturbed soil in accordance with the Standard Drawing. The concrete shall be placed so that fittings and valves will be accessible for repairs or replacement. Prior to filling the pipeline with water, the concrete for thrust and anchor blocks shall cure for the following number of days:

Thrust Blocks	3 days minimum
Anchor Blocks	7 days minimum

A. Pipe Thrust:

The following table lists the minimum bearing area (in square feet) for the noted fitting for each pipe size. The area shown is for each 100psi of test pressure, assuming a soil bearing pressure of 2,000psi. (For instance, if the test pressure is required to be 250psi, multiply the value in the table by 2.5.)

Pipe Size	Tees and Dead Ends	90° Bend	45° Bend	22½° Bend	11¼° Bend
6-inch	3.7	5.3	2.9	1.5	0.7
8-inch	6.4	9.1	4.9	2.5	1.3
10-inch	9.7	13.7	7.4	3.8	1.9
12-inch	13.7	19.4	10.5	5.3	2.7
14-inch	18.4	26.0	14.1	7.2	3.6
16-inch	23.8	33.6	18.2	9.3	4.7
18-inch	24.9	42.2	22.9	11.7	5.9
20-inch	36.6	51.8	28.0	14.3	7.2
24-inch	52.3	73.9	40.0	20.4	10.2
30-inch	80.4	113.7	61.6	31.4	15.8

B. Thrust Block Placement and Sizing:

Thrust blocks shall be located at all unrestrained pipe fittings and bear against firm, undisturbed soil. The thrust blocks shall be centered on the fitting so that the bearing area is exactly opposite the resultant direction of the thrust, refer to the Standard Drawings. Care shall be taken to prevent the placed thrust block concrete from eliminating maintenance access to the valve operators. All thrust block excavation, location, shape, and size shall be verified by the Engineering Manager prior to pouring concrete. The size shall be as indicated in Paragraph A above.

C. Anchor Block Placement and Sizing:

For all vertical bends in pipelines (downward bends) that do not have restrained joints, the fittings shall be retained in place by means of an anchor block. The block shall be sized to withstand the thrust exerted for the particular deflection angle at the required test pressure plus 10%. (Do not rely on the restraining benefit from the soil). The Engineering Manager shall verify the size chosen and the reinforcing steel required.

3.13 VALVE SUPPORT BLOCKS

Valve support blocks shall be installed as described below and in accordance with the Standard Drawings:

- A. Support blocks below valves shall be cut into the side of the trench a minimum of 12-inch.
- B. Support blocks shall extend up to the height of adjoining pipe and shall have a minimum depth below the valve of 12-inch.
- C. Support blocks shall be installed so that the valves will be accessible for repairs.

END OF SECTION 03300

SECTION 03461

PRECAST CONCRETE MANHOLES

PART 1 GENERAL

1.01 DESCRIPTION

This section includes materials, testing, and installation of precast concrete manholes for sewers and appurtenances.

1.02 REFERENCE STANDARDS

The publications listed below form part of this specification to the extent referenced and are referred to in the text by the basic designation only. Reference shall be made to the latest edition of said standards unless otherwise called for:

ASTM A48	Gray Iron Castings
ASTM C478	Precast Reinforced Concrete Manhole Sections
ASTM C478M	Precast Reinforced Concrete Manhole Sections [Metric]
ASTM C923	Resilient Connectors Between Reinforced Concrete Manhole Structures, Pipes and Laterals

1.03 RELATED WORK SPECIFIED ELSEWHERE

RMWD	Standard Drawings
Section 02223	Trenching, Backfilling and Compacting
Section 03300	Cast-in-Place Concrete

1.04 ACCESS MANHOLES FOR SEWER MAINS

48-inch diameter or 60-inch diameter shall be used for all sewer applications. Refer to Design Manual, Paragraph 2.03, Subparagraph D, Manholes.

1.05 DROP MANHOLES

The Engineering Manager must approve all drop manholes.

1.06 CORROSION PROTECTION

A corrosion protection lining and/or coating as described in this specification shall be applied to the interior of manholes for all:

1. New manholes on sewer mains 15-inches or larger.
2. Drop manholes regardless of sewer pipe size.
3. New manholes where entering pipe slope is 5-percent or greater.
4. Existing manholes receiving a new connection.
5. Manholes within 1,000 feet of receiving a force main discharge.

1.07 DAMP-PROOFING

A damp-proofing material shall be applied to the exterior portions of manholes in accordance with Specification Section 03300 and as directed by the Engineering Manager when located at or below the water table or when moisture or seepage is indicated.

1.08 JOINT SEALING

Joint sealant shall be used to form a continuous watertight seal on the concrete base and between successive precast concrete manhole or vault sections.

1.09 VACUUM TESTING OF MANHOLES

Vacuum testing of manholes is intended for testing precast concrete manhole sections to demonstrate the integrity of the installed materials and construction procedures.

PART 2 MATERIALS**2.01 PRECAST CONCRETE MANHOLES**

- A. Precast components and other appurtenant materials shall be selected from the Approved Materials List.
- B. Precast concrete manhole components shall be in accordance with ASTM C478 and the Standard Drawings.
- C. Manhole components shall be designed for H-20 highway wheel loading and specific site conditions.
- D. Manhole bases shall be cast-in-place with a formed recess shaped to match the first precast shaft section. The manhole base shall extend 12-inches below the bottom of the lowest pipe and 6-inches above the top of the largest pipe. Manhole bases for mains 18-inch or larger shall incorporate a 4-inch wide grating-support ledge, cast integrally with the drain channels, at the top of the base.
- E. Manhole shafts shall be fabricated only from precast shaft sections, eccentric cone sections and grade rings.
- F. Pipe penetrations for sewer applications shall incorporate a watertight flexible pipe connector or ring-type seal according to the method of manhole construction as shown in the Standard Drawings. Precast manholes shall utilize either an integrally cast embedded pipe connector, or a boot-type connector installed in a circular block out opening in accordance with ASTM C923. Connections to existing manholes shall utilize a boot type connector per ASTM C923 installed in a cored opening. Cast-in-place bases shall incorporate a ring-type seal on the pipe to be embedded in the concrete.
- G. Manholes on sewer mains 15-inch or larger, and all drop manholes regardless of the size of the sewer main, shall be PVC lined and polyurethane coated. Precast shaft sections, cone sections and grade rings on PVC-lined manholes shall have an integrally

locking PVC or polyurethane protective liner of 0.065-inch minimum thickness. A 100% solids elastomeric polyurethane coating shall be applied to exposed concrete at the interior of precast and cast-in-place bases.

2.02 CRUSHED ROCK BASE AND BACKFILL MATERIALS

Crushed rock base and backfill materials shall be in accordance with Specification Section 02223.

2.03 MANHOLE FRAMES AND COVERS

- A. Manhole frames shall be 36-inch in diameter with two concentric covers, made of cast-iron in accordance with ASTM A48, Class 30, the Standard Drawings and the Approved Materials List. Locking frames and covers, in accordance with the Standard Drawings are required in remote areas and as determined by the Engineering Manager.
- B. Frames and covers shall be designed for H-20 highway wheel loading.
- C. Covers shall have the words 'Rainbow MWD' and 'SEWER' cast into the cover as appropriate to the application. No other lettering will be permitted on the top portion of the cover.
- D. Castings shall be smooth, clean, and free from blisters, blowholes, and shrinkage. Mating surfaces of the frame and cover shall be machined to prevent movement of the lid. Frames and covers shall be match marked in sets before shipping to the site.
- E. All castings shall be dipped twice in a preparation of asphalt or coal tar and oil applied at a temperature of not less than 290° F nor more than 310° F and in such a manner as to form a firm and tenacious coating.

2.04 CONCRETE

Concrete used for manholes and appurtenances shall be in accordance with Specification Section 03300.

2.05 JOINT SEALING COMPOUND

Joint sealing compound shall be a mastic-type material in a flexible rope or rolled form with removable wrapper sized to fit into the key of manhole or vault sections. Joint sealing compound shall be selected from the Approved Materials List.

2.06 REPAIR MORTAR AND EPOXY BONDING AGENT

Repair mortar and an epoxy bonding agent shall be used to repair minor surface damage to precast sections or cast-in-place manhole bases at the discretion of the Engineering Manager. Repair products shall be in accordance with Specification Section 03300.

2.07 MORTAR

Mortar for use on joints between precast sections and for setting manhole cover frames shall be in accordance with Specification Section 03300.

2.08 DAMP-PROOFING

Damp-proofing material shall be in accordance with Specification Section 03300.

2.09 PVC LINER

Where required by the Engineering Manager, precast shaft sections, cone sections and grade rings on PVC-lined manholes shall have an integrally cast PVC T-shaped liner of 0.065-inch minimum thickness. A 100% solids elastomeric polyurethane coating shall be applied to exposed concrete at the interior of precast and cast-in-place bases.

PART 3 EXECUTION

3.01 WORK WITHIN EXISTING MANHOLES

Contractor shall comply with all Federal and State regulations for confined space entry. Work inside confined spaces, as defined by the applicable regulations, shall not be undertaken until all the tests and safety provisions of the Code of Federal Regulations 1910.146, and the General Industry Safety Orders of the California Code of Regulations, Title 8, Section 5159, for confined space entry have been performed and the area is verified as safe to enter. District policy prohibits entry into any confined space with Immediately Dangerous to Life and Health (IDLH) conditions except by trained emergency rescue personnel.

3.02 EARTHWORK

Manhole excavation, foundation stabilization (if necessary), placement of base material, backfill and compaction shall be performed in accordance with Specification Section 02223.

3.03 MANHOLE BASE

- A. The invert of the cast-in-place base shall be hand-worked to provide channels conforming in size to the inside diameter of the piping as indicated on the Approved Plans. The channels shall vary uniformly in size and shape from inlet to outlet. The concrete base shall be shaped with a wood float and shall receive a hard steel trowel finish before the concrete sets. A template shall be used to accurately form the level surface that will receive the first precast section.
- B. During construction of cast-in-place bases, all sewer mains and stub piping shall be in place, including ring-type seals, before concrete placement. Pipe grade and alignment shall be verified immediately upon placement of concrete to assure that the pipelines are in proper position prior to the concrete taking an initial set. The invert elevation and flow line of piping shall be as shown on the Approved Plans and Standard Drawings. The manhole base shall extend 12-inches below the bottom of the lowest pipe and 6-inch above the top of the largest pipe.

- C. Cast-in-place bases shall set a minimum of 24 hours before the manhole construction is continued. In certain critical situations, the setting time may be reduced upon approval of the Engineering Manager.

3.04 INSTALLING MANHOLE SECTIONS

- A. The concrete manhole base and successive precast sections will receive a mastic joint sealing compound prior to setting the precast sections in place as shown on the Standard Drawings. Following the vacuum testing as described in this section, the joints will be mortared and tooled to a smooth finish, free of voids. Note that sewer manholes are to be vacuum tested following assembly of the concrete sections, but prior to mortaring the joints, or backfilling.
- B. Manhole components incorporating a PVC liner and polyurethane coating shall be installed and tested in accordance with these specifications, the manufacturer's recommendations, and the Standard Drawings. Upon assembly of the precast sections and vacuum testing as described in this section, the mortaring and finishing of joints shall be performed. The PVC liner seams at the joints shall then be welded. The PVC liner shall be secured by insertion between the uppermost grade ring and the manhole cover frame. Note that PVC lined sewer manholes are to be vacuum tested following assembly of the concrete sections, but prior to mortaring the joints, welding the seams of the PVC liner, or backfilling. The polyurethane coating of all exposed concrete on the manhole base shall follow completion of the entire installation and all construction activity within the manhole.
- C. Assemble the precast sections to the elevation required by the location of the manhole as follows:
 1. Paved Areas: Top of cover shall be flush with the finished paving surface.
 2. Traveled Way: Top of cover shall be flush with the existing surface where it is in a traveled way.
 3. Shoulder Areas: Top of cover shall be 1-inch above the existing surface where outside the limits of a traveled way. Vaults shall not be placed in roadside ditches without the prior approval of the District.
 4. Unimproved easements: Top of cover shall be 6-inches above the ground surface. Guard Posts around the vault may be required in this area as directed by the District.
- D. Secure the manhole frame to the grade ring with mortar.
- E. After the frame is securely set the cover shall be installed. All necessary cleaning of foreign materials from the frames and covers shall be accomplished to ensure a satisfactory fit.
- F. Where manholes are to be given a protective coating, they shall be free of seepage and surface moisture.

- G. Piping installation adjacent to the manhole and connection to the base or shaft sections shall be performed as shown on the Standard Drawings and Approved Plans. Piping installation into flexible pipe connectors shall be in accordance with the manufacturer's recommendations for assembly, lubricants and limits of deflection.
- H. In order to prevent accidental use of the new sewer before completion and acceptance, the new inlet to existing tie-in manhole(s) and the outlet of the first new upstream manhole(s) shall be sealed with expandable plugs. The Engineering Manager shall approve the specific location of these plugs. Plugs shall be removed at the time of final inspection or as directed by the Engineering Manager. Removal of all construction debris and water shall be completed prior to removal of plugs.
- I. Brick or mortar bulkheads shall be installed by the Contractor at the manhole end of all unused stub channels over 36-inch beyond manhole base. The bulkheads are intended to prevent ponding of sewage and debris in the unused channels until such time as the manhole stub is connected and normal sewage flow can occur.
- J. New connections to existing manholes, where stubs have not been provided, shall be made by core drilling through the walls or base as directed by the Engineering Manager. Flexible seals selected from the Approved Materials List and installed in accordance with the Standard Drawings shall be used for the pipe penetration. Apply a protective epoxy coating to the cored concrete and the ends of any reinforcing steel exposed in accordance with Specification Section 03300.
- K. A concrete collar shall be cast around manhole frames in accordance with the Standard Drawings.
- L. Replacement of asphalt or concrete pavement shall be in accordance with the requirements of the agency having jurisdiction.

3.05 DAMP-PROOFING

At the discretion of the Engineering Manager, damp-proofing material shall be applied to the exterior surfaces of manholes in accordance with the manufacturer's recommendations and Specification Section 03300. The material shall be applied to all exterior surfaces below a point 12-inch above the water table or indications of seepage or moisture as directed by the Engineering Manager.

3.06 VACUUM TESTING OF MANHOLES

- A. Vacuum testing of manholes is required and shall be performed as directed in the presence of the District Inspector.
- B. Vacuum testing equipment shall be as manufactured by P.A. Glazier, Inc. or equal.
- C. Manholes shall be tested after assembly and prior to mortaring the joints or backfilling. In the case of manholes incorporating a PVC liner and polyurethane coating, the testing is to take place prior to mortaring the joints, welding the liner seams between sections, applying the coating, or backfilling.
- D. All lift holes shall be plugged with an approved grout prior to testing.

- E. All pipes entering the manhole shall be plugged, and bracing installed, to prevent the plug from being drawn into the manhole.
- F. The test head shall be placed inside the top of the cone section and the seal inflated in accordance with the manufacturer's recommendations.
- G. A vacuum of 10-inches of mercury shall be drawn. The time shall be measured for the vacuum to drop to 9-inches of mercury. The manhole shall pass the test if the time taken for the drop is greater than 60 seconds.
- H. If the manhole fails the test, necessary repairs shall be made and the test repeated until acceptable results are obtained. The leak(s) shall be located and repaired according to their nature with material-in-kind.

3.07 PULL TESTING OF PVC-LINED MANHOLES

PVC-lined manholes shall have field-welded joints pull tested. Field welds shall withstand a pull test of at least 100 lbs per liner inch, applied perpendicularly to the concrete surface for a period of one minute, without evidence of cracks or separations. This test shall be conducted at a temperature of 70° F to 80° F inclusive.

3.08 HOLIDAY TESTING OF PVC-LINED MANHOLES

PVC-Lined and Polyurethane-coated surfaces shall be holiday tested with an electrical holiday detector as manufactured by Tinker and Razor (Model #AP-W with power pack) with the instrument set at 20,000 volts and used as directed by the Engineering Manager. All imperfections identified on the PVC lining and polyurethane coating shall be repaired with materials-in-kind and the test shall be repeated until no holidays are evident.

END OF SECTION 03461

SECTION 05500**MISCELLANEOUS METALS****PART 1 GENERAL****1.01 DESCRIPTION**

This section includes furnishing and installing miscellaneous metal work as shown on the Standard Drawings and specified in this Section.

1.02 REFERENCE STANDARD

The publications listed below form part of this specification to the extent referenced and are referred in the text by the basic designation only. Reference shall be made to the latest edition of said standards unless otherwise called for.

AWS D1.1 / D10.4	Welding Procedure Specifications / Recommended Practices for Welding
ASTM A36 / A108	Specification for ESE(T) Structural Steel, Steel Bar, Carbon & Alloy Cold-Finished
ASTM A283	Specification for Carbon Steel Subjected to Sulphidation Process
ASTM A380	Standard Practice for Cleaning, Descaling & Passivation of Stainless Steel
ASTM A276	Specification for Stainless Steel Bars & Shapes
ASTM A479	Specification for Stainless Steel Bars & Shapes for use in Boilers/Other Press. Vessels
ASTM A312	Specification for Seamless, Welded & Heavily Cold Worked Austenitic Stainless Steel Pipes
ASTM A554	Specification for Welded Stainless Steel Mechanical Tubing
ASTM A564	Specification for Hot-Rolled & Cold Finished Age-Hardening Stainless Steel Bars/Shapes
ASTM E2016	Specification for Industrial Woven Wire Cloth
ASTM B209	Specification for Aluminum & Aluminum-Alloy Sheet & Plate
ANSI B1.1	Unified Screw and Pipe Threads
ASTM A307	Specification for Carbon Steel Bolts, Studs, & Threaded Rod Tensile Strength
ASTM A563	Specification for Carbon & Alloy Steel Nuts
ASTM F436	Specification for Hardened Steel Washers
ASTM A193 / A194	Specification for Alloy-Steel and Stainless Steel Bolting for High Temps/Pressure
ASTM F593 / F594	Specification for Stainless Steel Bolts, Hex Cap Screws & Studs
AWS A5.1/A5.17	Specification for Carbon Steel Electrodes & Fluxes for Submerged Arc Welding
AWS A5.4/ A5.9/ A5.10	Specification for Stainless Steel Electrodes for Shielded Metal Arc Welding
ASTM A143	Standard Practice for Safeguarding Against Embrittlement of Hot-Dip Galvanized Structural Steel
ASTM A384	Standard Practice for Safeguarding Against Warpage & Distortion During Hot-Dip Galv. of Steel Assem.
AWS D10.12	Mild Steel Pipe
AWS B2.1	SWPS-N for Gas Tungsten Arc Welding Austenitic Stainless Steel
ASTM A123 / A153	Specification for Zinc Coatings on Iron & Steel Products

1.03 SUBMITTALS

- A. Submittals shall be made in accordance with Specification Section 01300, Submittals, and the following special provisions provided herein.
- B. Shop Drawings. Before beginning fabrication of miscellaneous metal articles, the Contractor shall submit complete shop and erection drawings showing details of methods, materials, and finishes proposed for use. Shop drawings shall give complete information necessary for the fabrication of the component parts of the articles, including the location, type, and size bolts and welds. They shall clearly distinguish between shop and field bolts and welds.
- C. Test Reports and Certification documents shall be submitted as follows:
 - 1. Welding Procedure Specifications (WPS), per AWS D1.1, for welding procedures proposed for use in making production welds.
 - 2. Welding Procedure Qualification Record (PQR) to support welding procedures proposed for production welds not otherwise prequalified.
 - 3. Welding Performance Qualification for welders and welding operators to be employed on the Work.
 - 4. Certified mill test reports for chemistry and mechanical properties.
 - 5. Manufacturer's certification verifying conformance to these Specifications and that all products in contact with potable water are NSF-approved.

1.04 DELIVERY, STORAGE, AND HANDLING

- A. The Contractor shall take reasonable care in the proper handling and storage of articles or materials during erection operations to avoid accumulation of dirt and foreign matter. The Contractor shall remove from the articles or materials, dust, dirt, or other foreign matter that accumulates during construction. Coated surfaces shall be protected from abrasion or other damage during handling, storing, and erecting.
- B. Materials taken from stock by the Contractor shall be of a quality at least equal to that required by the ASTM specifications applicable to the classification covering the intended use and shall be supported by test reports prepared at the mill where the material was manufactured or at a testing laboratory approved by the Engineering Manager.

PART 2 MATERIALS

2.01 STEEL

- A. Carbon Steel
 - 1. Structural shapes shall be in accordance with ASTM A36.
 - 2. Bars and shapes shall be in accordance with ASTM A36 or ASTM A108 Grade 1018.

3. Plate 2 inches and less in thickness shall be in accordance with ASTM A36 or ASTM A283 Grade C or Grade D.

B. Stainless Steel

1. All welded stainless steel materials shall be pickled and passivated after fabrication in accordance with the requirements of ASTM A380. The Contractor shall use Avesta, or equal, pickling and passivating solution, for fieldwork.
2. Unless otherwise shown on the Drawings, materials in contact with water, intermittently or continuously, or in a wet or moist environment shall be stainless steel, Type 316 or 316L, where welding is required.
3. Stainless steel bars and shapes shall be in accordance with ASTM A276 Type 316 or Type 316L where welding is required, unless otherwise specified or shown on the Drawings.
4. Stainless steel plate, sheet, and strip, Type 316 or Type 316L where welding is required, unless otherwise specified or shown on the Drawings.
5. Rolled stainless steel shapes shall be in accordance with the requirements of ASTM A479, Type 316, or 316L where welding is required, heat treatment waived, unless otherwise specified or shown.
6. Stainless steel pipe shall be in accordance with ASTM A312 Type 316L.
7. Stainless steel tubing shall be in accordance with ASTM A554 Type MT316L.
8. Where shown on the Drawings, age-hardened stainless steel shall be in accordance with ASTM A564 Type 630, cold finished. Heat-treatment or age hardening shall be conducted at 900°F.
9. Stainless steel wire cloth shall conform to the requirements of ASTM E2016, Type 316.

C. Aluminum plate and sheet shall be in accordance with ASTM B209, Alloy No. 5052 H32.

D. Fasteners

1. Threads for bolts and nuts shall be in accordance with ANSI B 1.1.
 - a. Threads for bolts 1-inch and less in diameter shall be coarse-thread series and threads for bolts 1 1/8-inch and greater in diameter shall be the 8-pitch thread series.
 - b. The fit shall be Class 2 free fit; except that Class 3 medium fit shall be provided in holes tapped for studs.
2. Unless otherwise shown on the Drawings, bolts shall have heavy hexagon heads and heavy hexagon nuts.
3. The lengths of studs and bolts, excluding anchor bolts, shall provide a projection

of not less than 1/4-inch nor more than 1/2-inch through the nut when it is drawn tight; however, in exposed locations the projection shall be not more than 1/4-inch.

4. Carbon Steel Nuts and Bolts

- a. Carbon steel bolts, anchor bolts, and U-bolts, not in contact with water shall be in accordance with ASTM A307, Grade A.
- b. Carbon steel nuts not in contact with water shall be in accordance with ASTM A563.
- c. Steel washers shall be in accordance with ASTM F436.
- d. Carbon steel bolts greater than 1-inch in diameter shall be the 8-pitch thread series and shall be ferritic steel in accordance with ASTM A193, Grade B7. Accompanying nuts shall be in accordance with ASTM A194, Grade 2H.

5. Stainless Steel Fasteners

- a. Except as otherwise specified or shown on the Drawings, stainless steel fasteners shall be used where the material will be immersed in water, intermittently or continuously, or in moist-environment installations.
- b. Type 316 or 316N stainless steel fasteners shall be in accordance with ASTM A193 Grade B8MA or Grade B8MNA for bolting and stud material, and ASTM A194 Grade 8MA or Grade 8MNA for nuts. Fasteners for age-hardened stainless steel shall be manufactured in accordance with ASTM F593 and F594 Type 630.
- c. Stainless steel washers shall conform to ASTM F436 except that they shall be punched from steel conforming to ASTM 167 Type 316 or machined from bar stock conforming to ASTM A276 Type 316.
- d. Stainless steel studs, bolts, nuts, and washers shall be stamped indicating the type of stainless steel.

E. Welding Rods

1. Welding rods for welding carbon steel shall be E70XX low-hydrogen, in accordance with AWS A5.1 or A5.17 for welding carbon steel.
2. Electrodes for welding stainless steel shall be Type E316L in accordance with AWS A5.4 or AWS A5.9
3. Electrodes for welding stainless steel to carbon steel shall be Classification Number E309L or E312 in accordance with AWS A5.4 or A5.9.
4. Electrodes for welding aluminum shall be filler alloy 5356 in accordance with AWS A5.10.

F. Concrete anchors shall be in accordance with Specification Section 03250, Concrete Anchors.

G. Anti-Galling Compound

1. The anti-galling compound to be used on threads of stainless steel fastener assemblies shall be a compound certified by ANSI/NSF or EPA, for use in potable water systems.
2. Acceptable Products:
 - a. Ramco TRX-Synlube, Ramco Anti-Seize
 - b. Husk-It, Husky Lube-O-Seal
 - c. TRIPAC 2000
 - d. OAE

2.02 FABRICATION OF MISCELLANEOUS METALWORK

- A. The Contractor shall take the necessary precautions as described in ASTM A143 and ASTM A384 during fabrication of articles to be galvanized, to properly fabricate and prepare the material to prevent embrittlement, warpage, and distortion.
1. Violation of the provisions of this paragraph will be sufficient cause for rejection of the Work.
 2. Steel tubing with cover plates welded at both ends or other enclosed assemblies shall have vent and drain holes drilled at locations on the assembly approved by the Engineering Manager. The holes shall be drilled during fabrication and before galvanizing.
- B. All edges, corners, and welds shall be struck and deburred.

2.03 FABRICATION - WELDING OF CARBON STEEL

- A. Except for the modifications set forth in this Section, the welding of structures or articles fabricated from carbon steel shall be in accordance with the AISC Manual of Steel Construction and AWS D1.1 as referenced therein.
- B. Electroslag and electrogas welding procedures will not be permitted.
- C. Allowable unit stresses for base metals and for effective areas of weld metal for application to structures shall be as shown in the AISC Manual of Steel Construction.
- D. Joints to be welded by automatic machines shall be abrasive-blasted to white metal in accordance with SSPC-SP5.
- E. Electrodes for shielded metal arc welding (SMAW) shall not be larger than 1/4-inch for shop welding and not larger than 3/16-inch for field welding.
- F. The depth of each pass shall not exceed 1/8-inch for manual welding, and the weld puddle width shall not exceed three times the electrode diameter or 3/8-inch, whichever is less.

- G. Welding of pipe or tubing shall be in accordance with the recommendations of AWS D10.12.
- H. Runoff tabs shall be removed by hand flame-cutting or other means as close to the edge or the finished member as practical, followed by grinding to a smooth surface contiguous with the adjacent metal.

2.04 FABRICATION - WELDING OF STAINLESS STEEL

Welding of structures or articles fabricated from stainless steel shall be in accordance with the following:

- A. Welding on austenitic stainless steel shall be performed by the shielded metal arc process using direct current.
- B. Electrodes for welding austenitic stainless steels shall be in accordance with AWS A5.4 Classification Number E316L. Electrodes for welding stainless steel to carbon steel shall be Classification Number E309L or E312 electrodes.
- C. Weld procedures shall be qualified in accordance with AWS B2.1.
- D. Welding of stainless pipe or tubing shall be in accordance with the recommended practices of AWS D10.4.
- E. Stainless steel to carbon steel welds performed in the field will not require stress-relieving heat treatment provided the interpass temperature does not exceed 350°F.
- F. Stress-relieving of austenitic stainless steel where deemed necessary by Engineering Manager, shall be performed at 750°F for 4 hours, plus an additional 30 minutes for each additional inch over 1/2-inch weld section thickness, or a full solution anneal at 1900°F shall be performed with rapid quench.
- G. Stainless steel welds shall be deburred and ground smooth using grinding wheels of aluminum oxide. Carborundum or other carbon bearing wheels are not acceptable for use on stainless steel surfaces. Wire brushing of stainless steel surfaces shall be performed only with stainless steel brushes. Grind wheels and brushes used to clean stainless steel shall not have been used on carbon steel surfaces.
- H. After shop fabrication stainless steel shall be cleaned, descaled, and passivated in accordance with ASTM A380.

2.05 SHOP FINISHES

- A. Galvanizing
 - 1. Galvanizing shall have an average weight per square foot of 2.0 ounces and not less than 1.8 ounces per square foot.
 - 2. Except where otherwise specified, galvanizing shall be performed after fabrication, including cutting, punching, welding, and drilling, has been completed.

3. Prior to galvanizing, items shall be cleaned by abrasive blasting to white metal in accordance with SSPC-SP5.
 - a. Weld flux residue, weld splatter, and minor weld defects not removed by the abrasive blasting shall be removed by mechanical means.
 - b. After abrasive blasting and mechanical cleaning, items shall be fluxed and immediately hot dipped.
4. Galvanizing shall be done in the largest possible subassemblies consistent with the appearance of the completed item and with the prevention of warpage of the product.
5. Galvanizing shall be repaired in accordance with one of the methods specified in Part 3 of this Section.
6. Where galvanized light-gauge sheet goods are specified, upset edges of factory die-punched holes need not have the bare edges re-galvanized and the galvanized coating adjacent to such die-punched edges need not be repaired.

B. Aluminum

1. Aluminum shall be coated in accordance with Specification Section 09900, Painting and Coating Systems.
2. Where specified, aluminum materials shall receive a hard anodized finish after all fabrication work (holes, bends, etc.) has been completed.

PART 3 EXECUTION

3.01 INSTALLATION

- A. Installation and anchorage details for miscellaneous metal items shall be as shown on the Drawings. Details not shown shall be developed by the Contractor and indicated on the submittal shop drawings.
- B. Anti-galling compound shall be used each time stainless steel fasteners are assembled or reassembled and shall be applied in the fastener threads in accordance with the manufacturer's printed recommendations.

3.02 REPAIR OF GALVANIZED SURFACES

Areas of galvanizing damaged during fabrication, shipping, erection, or any other time prior to acceptance of the Work shall be prepared and recoated by one of the following methods:

- A. Parts damaged in the shop shall be removed from the site, stripped of existing coating, cleaned, and re-galvanized in accordance with ASTM A123 or A153 as applicable.
- B. Field or shop repair areas shall be cleaned and recoated with a 2.0 mil coating of zinc alloy using meltable zinc-based alloy bars (hot bar process).

1. The damaged area shall be thoroughly cleaned using a wire brush, a light grinding action or mild abrasive blasting. The cleaning shall extend beyond the damaged area to lap the undamaged galvanized coating at least 1/2-inch.
 2. Weld flux residue, and weld splatter of a size or type that cannot be removed by blast cleaning shall be removed by chipping, scaling or other mechanical means.
 3. The cleaned area shall be preheated to at least 600°F but not more than 750°F. The surrounding galvanized area shall not be burned. The area to be repaired shall be wire brushed during this preheat.
 4. The cleaned preheated area shall be rubbed with the repair alloy stick to deposit an evenly distributed layer of the zinc alloy.
 5. The repaired area shall be wiped with a damp cloth to remove flux residue.
 6. Dry –film thickness shall be verified using a magnetic or electromagnetic-type gauge.
- C. Shop or field-damaged areas shall be cleaned and recoated with a 4.0 mil minimum coating of zinc, using sprayed zinc (metalizing process).
1. Zinc wire used in repair shall contain not less than 99.98% zinc.
 2. The surface to be repaired shall be blast cleaned to white metal in accordance with SSPC-SP5. The area to be blast cleaned shall extend at least 1/2-inch onto the surrounding sound coating area.
 3. Weld flux residue and weld splatter of a size or type that cannot be removed by blast cleaning shall be removed by chipping, scaling, or other mechanical means.
 4. Sprayed coating shall be applied within 2 hours after surface preparation has been completed and before any visible deterioration (flash-rust) has occurred.
 5. The coating shall be applied to the clean and dry surface by metal spraying pistols fed with zinc wire or zinc powder.
 6. The surface of the sprayed zinc shall be of uniform texture, free of lumps, coarse areas, and loosely adhered particles.
 7. Dry film thickness shall be verified using a magnetic or electromagnetic-type, gauge.
- D. In the field, for areas where the hot bar or metalizing process methods cannot be used, and with the permission of the Engineering Manager, the damaged areas shall be repaired with multiple coats of an approved coating such as Rustoleum Zinc Rich Cold Galvanizing Aerosol; CRC Zinc-It; Spray-on #740 zinc-rich; Sherwin Williams #140 Zinc-Rich; OAE.
1. The damaged area shall be cleaned and recoated with an organic zinc-rich paint to a minimum dry film thickness (DFT) of 6.0-mils applied in two coats.
 2. The surface to be repaired shall be blast cleaned to white metal in accordance with SSPC-SP5. The area to be blast cleaned shall extend at least 1/2-inch onto the

surrounding sound coating area.

3. Weld flux residue and weld splatter of a size or type that cannot be removed by blast cleaning shall be removed by chipping, scaling or other mechanical means.
4. In areas where abrasive blasting cannot be used or cannot effectively clean the required area, power disk sanding or other cleaning methods shall be used, subject to the approval of the Engineering Manager.
5. Apply paint containing zinc dust to the prepared area as recommended by the paint manufacturer.
6. Dry film thickness shall be verified using a magnetic or electromagnetic-type gauge.

END OF SECTION 05500

SECTION 09900**PAINTING AND COATING****PART 1 GENERAL****1.01 DESCRIPTION**

This section described the requirements for the preparation of surfaces and subsequent application of protective coatings. The Contractor shall furnish all labor, materials and equipment required for satisfactory completion of all items contained herein. The Contractor shall furnish all necessary safety equipment and protective clothing, as well as be responsible for proper instruction and supervision of their use.

1.02 SUBMITTALS

Contractor shall furnish submittals in accordance with the requirements of Section 1 – General Conditions. The following submittals are required:

- A. Submit a chart of the manufacturer's available colors for color selection well in advance of painting operation.
- B. Submit manufacturer's data sheets showing the following information:
 - 1. Recommended surface preparation.
 - 2. Minimum and maximum recommended dry-film thicknesses per coat for prime, intermediate, and finish coats.
 - 3. Percent solids by volume.
 - 4. Recommended thinners.
 - 5. Statement verifying that the selected prime coat is recommended by the manufacturer for use with the selected intermediate and finish coats.
 - 6. Application instructions including recommended application, equipment, humidity, and temperature limitations.
 - 7. Curing requirements and instructions.
- C. Submit certification that all coatings conform to applicable local Air Quality Management District rules and regulations for products and application.

PART 2 MATERIALS**2.01 GENERAL**

- A. All materials shall be those of current manufacture and shall meet all applicable regulations for the application and intended service. All coats of any particular coating system shall be of the same manufacturer and shall be approved by the manufacturer for the intended

service. In the event that a product specified herein is no longer manufactured or does not meet current regulations, the Contractor shall provide a substitute, currently manufactured product of at least equal performance which meets all applicable regulations, subject to the Engineering Manager's approval, at no additional cost.

- B. All materials shall be delivered to the Project Site in their original, unopened containers bearing the manufacturer's name, brand, and batch number. Standard products of manufacturers other than those specified will be accepted when it is proved to the satisfaction of the Engineering Manager they are equal in composition, durability, usefulness and convenience for the purpose intended.

Ameron Corrosion Control Division, Brea, CA
ICI Devoe Coatings, Strongsville, OH
Tnemec Company, Inc., Kansas City, MO, 64141

- C. All surfaces to be coated or painted shall be in the proper condition to receive the material specified before any coating or painting is done. No more sandblasting or surface preparation than can be coated or painted in a normal working day will be permitted. All sharp edges, burrs, and weld spatter shall be removed. All concrete and masonry surfaces shall cure 30 days prior to coating or painting.
- D. Surface preparation, prime coatings, and finish coats for the various systems are specified herein. Unless otherwise noted, all intermediate and finish coats shall be of contrasting colors. It is the intent that the coating alternates specified herein serve as a general guide for the type of coating desired.

2.02 VALVES

- A. Exterior Coating: Coat ferrous valves located above ground, in vaults or in structures the same as the adjacent piping. If the adjacent piping is not coated, then coat valves per this Specification section unless otherwise noted. Apply the specified prime coat at the place of manufacture. Apply intermediate and finish coats in the field. Finish coat shall match the color of the adjacent piping. Coat handwheels and floor stands the same as the valves. Coat the exterior of buried metal valves at the place of manufacture per this specification.
- B. Exterior Coating (Above ground):
Shop prime coat: Tnemec Series 1 Omnithane applied at 2.5 to 3.5 mils DFT.
Touch-up (Field): Tnemec Series 1 Omnithane applied at 2.5 to 3.5 mils DFT.
Intermediate Coat: Tnemec Series V69 Epoxoline II applied at 3.0 to 5.0 mils DFT.
Finish Coat: Tnemec Series 1075 Endura-Shield II @ 2.0 to 3.0 mils DFT.
- C. Exterior Coating (Buried):
Shop prime coat: Tnemec Series 1 Omnithane applied at 2.5 to 3.5 mils DFT.
Shop Intermediate Coat: Tnemec Series V69 Epoxoline II applied at 4.0 to 6.0 mils DFT.
Shop Finish Coat: Tnemec Series V69 Epoxoline II applied at 4.0 to 6.0 mils DFT.
- D. Interior Lining: Valves 4-inches and larger shall be coated on their interior metal surfaces excluding seating areas and bronze and stainless-steel pieces. Sandblast surfaces in accordance with SSPC-SP-10 (near white blast cleaning). Remove all protuberances which may produce pinholes in the lining. Round all sharp edges to be coated. Remove any contaminants which may prevent bonding of the lining. Coat the interior ferrous surfaces using one of the following methods:

1. Apply powdered thermosetting epoxy per the manufacturer's application recommendations to a thickness of 10 to 12 mils.
2. Apply two (2) coats of polyamide epoxy to a dry-film thickness of 10 to 12 mils total. Follow the manufacturer's application recommendations including minimum and maximum drying time between the required coats.
3. All epoxy lining shall be applied at the factory by the manufacturer of the valve, and shall meet current Volatile Organic Compound (VOC) content regulations. Epoxy lining for potable water valves shall also be listed by National Sanitation Foundation (NSF) for contact with potable water.
4. Test the valve interior linings at the factory with a low-voltage holiday detector. The lining shall be holiday free.

2.03 METAL, INTERIOR AND EXTERIOR, NORMAL EXPOSURE

- A. General: The Contractor shall paint all exposed steelwork, non-galvanized handrails, exposed pipework, fittings, all mechanical equipment, pumps, motors, doors, door frames and window sash with this coating system. All metalwork previously given a shop prime coat approved by the Engineering Manager shall be touched up as required in the field with an approved coating.
- B. Surface Preparation: All exterior metal surfaces which are to be painted shall be commercial blast cleaned per Specification SP-6 (commercial blast cleaning) except as otherwise specified, in locations where sandblasting would damage previously coated surfaces and installed equipment, and in locations where dry sandblasting is prohibited. The above locations in which SP-6 commercial sandblasting is not possible shall be given a SP-3 power tool cleaning. This sandblasting shall be done not more than 8 hours ahead of the painting, subject to humidity and weather conditions between the time of sandblasting and painting operations. If any rusting or discoloration of sandblasted surfaces occurs before painting, such rusting or discoloration shall be removed by additional sandblasting. Sandblasted surfaces shall not be left overnight before painting.
- C. Coating:
 1. Prime coat or spot prime coat: Tnemec Series 18 Enviro-Prime applied at 2.0 to 3.5 mils DFT.
 2. Intermediate Coat: Tnemec Series 1028 Tufcryl Gloss Acrylic applied at 2.0 to 2.5 mils DFT.
 3. Finish Coat: Tnemec Series 1028 Tufcryl Gloss Acrylic applied at 2.0 to 2.5 mils DFT.
 4. Total dry-film thickness of the complete system shall be 6.0 to 8.5 mils DFT.

2.04 METAL, SUBMERGED OR INTERMITTENTLY SUBMERGED

- A. General: All submerged metalwork, gates, equipment, valves, exposed pipework and all other metalwork within areas which will be submerged, except as noted hereinafter, shall be painted with this coating system.
- B. Surface Preparation: All metal surfaces shall be field sandblasted according to SSPC-SP-10 (near white blast cleaning).
- C. Coating:
1. Coating (Potable water):
 Prime coat: Tnemec Series V140 or V140F Pota-Pox Plus applied at 4.0 to 6.0 mils DFT.
 Intermediate coat: Tnemec Series V140 or V140F Pota-Pox Plus applied at 4 to 6 mils DFT.
 Finish coat: Tnemec Series V140 or V140F Pota-Pox Plus applied at 4 to 6 mils DFT.
 Total dry-film thickness of the complete system shall be 12.0 to 18.0 mils.
 2. Coating (Non-potable):
 Primer: Tnemec Series V69 Epoxoline II applied at 4 to 6 mils DFT.
 Intermediate coat: Tnemec Series V69 Epoxoline II applied at 4 to 6 mils DFT.
 Finish coat: Tnemec Series V69 Epoxoline II applied at 4 to 6 mils DFT.
 Total dry-film thickness of the complete system shall be a 12.0 to 18.0 mils DFT.

NOTE: Tnemec Series V140 or V140F can also be used for Non-Potable system.

2.05 METAL, SEVERE EXPOSURE TO MOISTURE OR CHEMICAL FUMES

- A. Surface Preparation: All metal surfaces shall be field sandblasted according to SSPC-SP-10 (near white blast cleaning).
- B. Coating:
1. Exterior Coating:
 Shop prime coat: Tnemec Series 90-97 Tneme-Zinc applied at 2.5 to 3.5 mils DFT.
 Touch-up (Field): Tnemec Series 90-97 Tneme-Zinc applied at 2.5 to 3.5 mils DFT.
 Intermediate Coat: Tnemec Series V69 Epoxoline II applied at 3.0 to 5.0 mils DFT.
 Finish Coat: Tnemec Series 1075 Endura-Shield II @ 2.0 to 3.0 mils DFT.
 2. Interior Coating:
 Shop prime coat: Tnemec Series 90-97 Tneme-Zinc applied at 2.5 to 3.5 mils DFT.
 Touch-up (Field): Tnemec Series 90-97 Tneme-Zinc applied at 2.5 to 3.5 mils DFT.
 Intermediate Coat: Tnemec Series V69 Epoxoline II applied at 4.0 to 6.0 mils DFT.
 3. Finish Coat: Tnemec Series V69 Epoxoline II applied at 4.0 to 6.0 mils DFT.

2.06 METAL, HIGH-TEMPERATURE EXPOSURE

- A. General: Engine mufflers, exhaust systems and other metal surfaces subjected to high temperatures shall be coated with this system.
- B. Surface Preparation: Surface shall be field sandblasted in accordance with SSPC-SP-10 (near white blast cleaning).
- C. Coating (Tnemec Alternate): One coat of Tnemec Series 90-96 Tneme-Zinc to a total dry-film thickness of 2.5 to 3.5 mils.
- D. Coating (ICI Devoe Coatings Alternate): One coat of Catha-Coat 304V Zinc to a dry-film thickness of 2 to 4 mils.

2.07 METAL, GALVANIZED, ALUMINUM, COPPER, OR BRASS

- A. Surface Preparation: Surfaces shall be solvent cleaned in accordance with SSPC-SP-1 (solvent cleaning) and SSPC-SP- (Brush off Blast cleaning). Next, apply recommended coating or paint for the particular surface to be coated.
- B. Coating Interior Exposed:
Prime coat: Primer: Tnemec Series V69 Epoxoline II applied at 2 to 3 mils DFT.
Finish coat: Tnemec Series V69 Epoxoline II applied at 2 to 3 mils DFT.
Total try-film thickness of the complete system shall be 4.0 to 6.0 mils.
- C. Coating Exterior Exposed:
Prime coat: Primer: Tnemec Series V69 Epoxoline II applied at 2 to 3 mils DFT.
Finish coat: Tnemec Series 1075 Endura-Shield II applied at 2 to 3 mils DFT.
Total try-film thickness of the complete system shall be 4.0 to 6.0 mils.
- D. Coating (Sinclair Alternate) 7113 Wash Primer applied at ½ mil dry-film thickness.

2.08 METAL, BURIED

- A. General: The Contractor shall coat all buried metal which includes valves, bolts, nuts, structural steel and fittings. It does not include steel storage reservoirs.
- B. All buried flanges, fittings, and nuts and bolts shall be wrapped per AWWA C-217 and wrapped with polyethylene encasement per AWWA C – 105. Nuts and Bolts shall be individually wax taped per RMWD Standard Drawing CP-9 notes. Buried Valves shall be wrapped with polyethylene encasement per AWWA C-105.
- C. Surface Preparation: Sandblast to SSPC-SP-6 (commercial blast cleaning)
- D. Coating (Tnemec Alternate): Prime Coat: Tnemec Series 46H-413 Hi-Build Tneme-Tar applied at 8.0 to 10.0 mils DFT. Finish Coat: Tnemec Series 46H-413 Hi-Build Tneme-Tar applied at 8.0 to 10.0 mils DFT. Total dry-film thickness shall be 16.0 to 20 mils.

2.09 MASONRY, EXTERIOR, NORMAL EXPOSURE

- A. General: All exterior masonry surfaces subject to normal exposure shall be painted with this system.

- B. **Surface Preparation:** Surfaces shall be free of dirt, dust, grease, or other deleterious matter before coating. All cracks and voids shall be filled with a suitable caulking material compatible with the specified coating.
- C. **Coating (Tnemec Alternate):** Prime Coat: Tnemec Series 180 W.B. Tneme-Crete, 4.0 to 6.0 mils DFT. Finish Coat: Tnemec Series 180 W.B. Tneme-Crete, 4.0 to 6.0 mils DFT. Total dry-film thickness shall be 8 to 12 mils.
- D. **Coating (ICI Devoe Coatings Alternate):** Two (2) coats of Devflex 4020 Acrylic, 2.5 to 3.5 mils dry-film thickness, each. Total dry-film thickness shall be 6 mils minimum.

2.10 MASONRY, INTERIOR

- A. **Surface Preparation:** For concrete surfaces, surfaces to be coated must be sandblasted according to SSPC-SP-7 (brush-off blast cleaning) with 60-80 mesh sand and air pressure 50-60 psi to remove all cement glaze and residue of form release agents and provide a uniform surface profile of approximately 1 mil. Fill voids, holes, and pits with Tnemec Series 104 H.S. Epoxy sprayed and backrolled to create a void-free surface or (Devoe Coating) Tru-Glaze 4015 Epoxy applied as required. Vacuum clean or air blast surface prior to coating. Surfaces shall cure a minimum of 28 days prior to coating.
- B. **Interior Coating (Tnemec Alternate):** CMU Coating System: Block Filler / Prime Coat: Tnemec Series 130 Envirofill applied at 60 to 115 sq ft/gal to create a void-free surface. Intermediate coat: Tnemec Series V69 Epoxoline II applied at 4 to 6 mils DFT. Finish coat: Tnemec Series V69 Epoxoline II applied at 4 to 6 mils DFT. Total dry-film thickness of the complete system shall be a minimum of 8-12 mils not including block filler.
- C. **Concrete System:** Filler Coat: Tnemec Series 218 Mortar-Clad as required to fill bugholes and cracks in concrete. Intermediate coat: Tnemec Series V69 Epoxoline II applied at 4 to 6 mils DFT. Finish coat: Tnemec Series V69 Epoxoline II applied at 4 to 6 mils DFT. Total dry-film thickness of the complete system shall be a minimum of 8-12 mils not including filler.

2.11 MASONRY, SEVERE EXPOSURE

- A. **General:** This system is for interior and exterior masonry surfaces subject to severe exposure or chemical attack.
- B. **Surface Preparation:** Surfaces to be coated must be sandblasted according to SSPC-SP-7 (brush-off blast cleaning) with 60-80 mesh sand and air pressure of 50-60 psi to remove all cement glaze and residue of form release agents and provide a uniform surface profile of approximately 1 mil. Fill voids, holes, and pits with Tnemec Series 104 H.S. Epoxy sprayed applied as required. Vacuum clean or air blast surface prior to coating. Surfaces shall cure a minimum of 28 days prior to coating.
- C. **Coating (Tnemec Alternate):** CMU Coating System: Block Filler / Prime Coat: Tnemec Series 130 Envirofill applied at 60 to 115 sq ft/gal to create a void-free surface. Intermediate coat: Tnemec Series 104 H.S. Epoxy applied at 6 to 8 mils DFT. Finish coat: Tnemec Series 104 H.S. Epoxy applied at 6 to 8 mils DFT. Total dry-film thickness of the complete system shall be a minimum of 12-16 mils not including block filler.

- D. Concrete System: Filler Coat: Tnemec Series 218 Mortar-Clad as required to fill bug holes and cracks in concrete. Intermediate coat: Tnemec Series 104 H.S. Epoxy applied at 6 to 8 mils DFT. Finish coat: Tnemec Series 104 H.S. Epoxy applied at 6 to 8 mils DFT. Total dry-film thickness of the complete system shall be a minimum of 12-16 mils not including filler.

2.12 CONCRETE FLOORS

- A. General: Includes specified concrete floors subject to moisture and pedestrian traffic.
- B. Surface Preparation: Surfaces to be coated must be sandblasted in accordance with SSPC-SP-7 (brush-off blast cleaning) with 60-80 mesh sand and air pressure of 50-60 psi to remove all cement glaze and residue or other agents and provide a uniform surface profile of approximately 1 mil.
- C. Coating (Tnemec Alternate): Floor Coating: Prime Coat: Series 201 Epoxoprime applied at 4.0 to 6.0 mils DFT. Intermediate Coat: Tnemec Series 280 Tneme-Glaze at 6 to 8 mils DFT. Finish Coat: Tnemec Series 280 Tneme-Glaze at 6 to 8 mils DFT. Total dry-film thickness shall be 16.0 to 22 mils.

2.13 WOODWORK - INTERIOR AND EXTERIOR

- A. General: The Contractor shall paint all interior and exterior wood including, but not limited to, doors, frames, panels, sash and trim.
- B. Surface Preparation: Surfaces shall be clean, dry, and free of all contaminants. All surfaces shall be sanded smooth. Knots, pitch pockets, and other bleed points shall be sealed with a shellac-based sealer after areas are scraped clean and sanded. Holes and imperfections shall be spot-primed, filled with plastic wood filler, and sanded smooth. All surfaces shall be dusted clean prior to coating. Moisture content shall be tested using an electronic moisture meter and shall not exceed 15%.
- C. Coating (Tnemec Alternate): Interior & Exterior Coating: Prime coat: Tnemec Series 151-1051 Elastic-grip FC applied at 1 mil DFT. Intermediate Coat: Tnemec Series 1029 Tufcryn Semi-Gloss applied at 1.5 to 2.0 mils DFT. Finish Coat: Tnemec Series 1029 Tufcryn Semi-Gloss applied at 1.5 to 2.0 mils DFT. Total dry-film thickness of the complete system shall be 4.0 to 5.0 mils DFT.

2.14 PLASTER, DRYWALLS - INTERIOR

- A. Surface Preparation: Surfaces shall be free of dirt, dust, grease, or other deleterious matter before coating. All cracks and voids shall be filled with a suitable spackling material compatible with the specified coating.
- B. Coating (Tnemec Alternate): Coating: Prime coat: Tnemec Series 51-792 Sealer applied at 1 to 2 mils dry-film thickness. Finish coats(2): Tnemec Series 6 Tneme-Cryl applied at 2 to 3 mils dry-film thickness, each. Total dry-film thickness shall be 5.0 to 8 mils.

PART 3 EXECUTION**3.01 GENERAL**

- A. The Contractor shall arrange with the Engineering Manager so that all surface preparation may be inspected and approved prior to the application of any coatings.
- B. The Contractor is hereby notified that the Engineering Manager will inspect the Work prior to the expiration of the warranty period and all defects in workmanship and material shall be repaired by the Contractor, at his own expense.

3.02 WORKMANSHIP

- A. It is the intent of the Specifications that finishes shall be provided which meet standards for best grades of painting. Drop cloths shall be placed where required to protect floors, surfaces and equipment from spatter and dropping, not to receive paint or coatings.
- B. The Contractor shall take all necessary precautions to protect all adjacent Work and all surrounding property and improvements from any damage whatsoever as a result of the painting and coating operation.
- C. Only good, clean brushes and equipment shall be used and all brushes, buckets, and spraying equipment shall be cleaned immediately at the end of each painting period.
- D. Each coat of paint shall be of the consistency as supplied by the manufacturer, or thinned, if necessary, and applied in accordance with manufacturer's instructions. Each coat shall be well brushed, rolled or sprayed to obtain a uniform and evenly applied finish. Work shall be free from "runs", "bridges", "shiners", or other imperfections due to faulty intervals. Particular care shall be taken to obtain a uniform unbroken coating over all bolts, threads, nuts, welds, edges and corners. Paint shall not be applied in extreme heat, in dust or smoke laden air, or in damp or humid weather, unless written permission of the Engineering Manager is obtained.
- E. If paint is applied by spray, the air pressure used shall be within the ranges recommended by both the paint and spray equipment manufacturers. Spray painting shall be conducted under controlled conditions and the Contractor shall be fully responsible for any damage occurring from spray painting.
- F. Care shall be exercised not to damage adjacent Work during sandblasting operations. Stainless steel need not be sandblasted. Blasted surfaces shall not be left overnight before coating. All dust shall be removed from the surface following sandblasting.

3.03 APPLICATION PROCEDURES

- A. Surfaces to be Coated: All surfaces of materials furnished and constructed are to be painted or coated per the Specifications except as indicated below.
- B. Surfaces Not To Be Coated: The following surfaces shall not be coated unless otherwise noted on the Plans and shall be fully protected when adjacent areas are painted:

Aluminum grating	Grease fittings	Nameplates on machinery
Aluminum surfaces	Hardware	Pipe interior*
Bearings	Lighting fixtures	Shafts
Brass and copper tubing, submerged*	Machined surfaces	Stainless steel
Buried pipe	Metal letters	Switch plates
Couplings	Mortar-coated pipe & fittings	

* unless specifically required on the Plans or elsewhere in the Specifications

C. **Protection of Surfaces Not To Be Coated:** Surfaces not intended to be painted shall be removed, masked, or otherwise protected. Drop cloths shall be provided to prevent paint materials from falling on or marring adjacent surfaces. Working parts of mechanical and electrical equipment shall be protected from damage during surface preparation and painting process. Openings in motors shall be safely masked to prevent paint and other materials from entering the motors. All masking materials shall be completely removed and surfaces cleaned at completion of painting operations.

D. **Weather Conditions:**

1. Paint shall not be applied in the rain, wind, snow, mist, and fog or when steel or metal surface temperatures are less than 5°F above the dew point.
2. Paint shall not be applied when the relative humidity is above 80%, the air temperature is above 90°F, or the temperature of metal to be painted is above 125°F.
3. Alkyd, chlorinated rubber, inorganic zinc, silicone aluminum, or silicone acrylic paints shall not be applied if air or surface temperature is below 50°F or expected to be below 50°F within 24 hours.
4. Epoxy, coal tar epoxy, acrylic latex, and polyurethane paints shall not be applied on an exterior or interior surface if air or surface temperature is below 50°F or expected to drop below 50°F within 24 hours.

3.04 SURFACE PREPARATION

A. **General:** Sandblast or prepare only as much surface area as can be coated in one day. All sharp edges, burrs, and weld spatter shall be removed. Epoxy-coated pipe that has been factory coated shall not be sandblasted.

B. **SSPC Specifications:**

1. Wherever the words "solvent cleaning", "hand tool cleaning", "wire brushing", or "blast cleaning" or similar words are used in the Specifications or in paint manufacturer's specifications, they shall be understood to refer to the applicable SSPC (Steel Structures Paint Council, Surfaces Preparation Specifications, ANSI A159.1) Specifications listed below:

SP-1 Solvent Cleaning	SP-6 Commercial Blast Cleaning
SP-2 Hand Tool Cleaning	SP-7 Brush-Off Blast Cleaning
SP-3 Power Tool Cleaning	SP-8 Pickling
SP-5 White Metal Blast Cleaning	SP-10 Near White Blast Cleaning

2. Oil and grease shall be removed from aluminum and copper surfaces in accordance with SSPC SP-1 using clean cloths and cleaning solvents.

3. Weld spatter and weld slag shall be removed from metal surfaces. Rough welds, beads, peaked corners, and sharp edges including erection lugs shall be ground smoothly in accordance with SSPC SP-2 and SSPC SP-3.
4. Welds shall be neutralized with a chemical solvent that is compatible with the specified coating materials using clean cloths and chemical solvent.

C. Abrasive Blast Cleaning:

1. Dry abrasive blast cleaning shall be used for metal surfaces. Do not recycle or reuse contaminated blast particles.
2. Dry clean surfaces to be coated by dusting, sweeping, and vacuuming to remove residue from blasting. Apply the specified primer or touch-up coating within the period of an 8-hour working day. Do not apply coating over damp or moist surfaces. Reclean prior to application of primer or touch-up coating any blast cleaned surface not coated within said 8-hour period.
3. Prevent damage to adjacent coatings during blast cleaning. Schedule blast cleaning and coating such that dust, dirt, blast particles, old coatings, rust, mill scale, etc., will not damage or fall upon wet or newly coated surfaces.

3.05 PROCEDURES FOR THE APPLICATION OF COATINGS

- A. The recommendations of the coating manufacturer shall be followed, including the selection of spray equipment, brushes, rollers, cleaners, thinners, mixing, drying time, temperature and humidity of application, and safety precautions.
- B. Coating materials shall be kept at a uniform consistency during application. Each coating shall be applied evenly, free of brush marks, sags, runs, and other evidence of poor workmanship. A different shade or tint shall be used on succeeding coating applications to indicate coverage where possible. Finished surfaces shall be free from defects or blemishes.
- C. Only thinners recommended by the coating manufacturer shall be used. If thinning is allowed, do not exceed the maximum allowable amount of thinner per gallon of coating material.
- D. Apply a brush coat of primer on welds, sharp edges, nuts, bolts, and irregular surfaces prior to the application of the primer and finish coat. The brush coat shall be done prior to and in conjunction with the spray coat application. Apply the spray coat over the brush coat.
- E. Apply primer immediately after blast cleaning and before any surface rusting occurs, or any dust, dirt, or any foreign matter has accumulated. Reclean surfaces by blast cleaning that have surface colored or become moist prior to coating application.
 1. **Paint Mixing:** Multiple-component coatings shall be prepared using all the contents of each component container as packaged by the paint manufacturer. Partial batches shall not be used. Multiple-component coatings that have been mixed beyond their pot life shall not be used. Small quantity kits for touch-up painting and for painting

other small areas shall be provided. Only the components specified and furnished by the paint manufacturer shall be mixed. For reasons of color or otherwise, additional components shall not be intermixed, even within the same generic type of coating.

2. **Field Touch Up of Shop-Applied Prime Coats: Organic Zinc Primer:** Surfaces that are shop primed with zinc rich primers shall receive a field touch up of organic zinc primer to cover all scratches or abraded areas. Organic zinc coating system shall have a minimum volume solids of 62% and a minimum zinc dust content of 83% by weight in the dried film. Coating shall be of urethane type and shall be manufactured by the prime coat and finish coat manufacturer.
3. **Other Primers:** Surfaces that are shop primed with other than organic zinc primer shall receive a field touch up of the same primer used in the original prime coat.

3.06 DRY-FILM THICKNESS TESTING AND REPAIR

- A. **Special Instructions to the Contractor:** The Contractor shall furnish to the District at no charge for use during execution of the Work, necessary dry-film thickness gauge and electrical flaw detection equipment. The Contractor shall perform the holiday (pinholes) inspection in the presence of the Engineering Manager, and the Contractor shall monitor wet film measurements throughout the application of each coat of coating.
- B. **Coating Thickness Testing:** Coating thickness specified for steel surfaces shall be measured with a magnetic-type dry-film thickness gauge. Dry-film thickness gauge shall be provided as manufactured by Mikrotest or Elcometer. Each coat shall be checked for the correct dry-film thickness. Measurement shall not be made until a minimum of eight hours after application of the coating. Non-magnetic surfaces shall be checked for coating thickness by micrometer measurement of cut and removed coupons. Contractor shall repair coating at all locations where coupons are removed.
- C. **Holiday Testing:** The finish coat (except zinc primer and galvanizing) shall be tested by the Contractor for holidays and discontinuities with an electrical holiday detector of the low-voltage, wet-sponge type. All testing shall be done in the presence of the Engineering Manager and conducted per manufacturer's written recommendations. All Holiday testing shall be in conformance with NACE RP 0188-88 / RP 0490.
- D. **Repair:** If the item has an improper finish, color, insufficient film thickness, or holidays, the surface shall be cleaned and top-coated with the specified paint material to obtain the specified color and coverage. Visible areas of chipped, peeled, or abraded paint shall be hand or power-sanded, feathering the edges. The areas shall then be primed and finish coated in accordance with the Specifications. Work shall be free of runs, bridges, shiners, laps, or other imperfections.

3.07 CLEANUP

Upon completion of all painting and coating Work, the Contractor shall remove all surplus materials and rubbish. The Contractor shall repair all damage and shall leave the premises in a clean and orderly condition.

END OF SECTION 09900

SECTION 09954**POLYETHYLENE SHEET OR TUBE ENCASUREMENT****PART 1 GENERAL****1.01 DESCRIPTION**

This section includes materials, application, and inspection of polyethylene sheet or tube encasement for buried steel and iron pipe, fittings, couplings, valves, and appurtenances.

1.02 RELATED WORK SPECIFIED ELSEWEHRE

RMWD Standard Drawings

1.03 SUBMITTALS

- A. Contractor shall furnish submittals in accordance with the requirements of Section 1 – General Conditions.
- B. Submit manufacturer's catalog literature and product data sheets describing the physical, chemical and electrical properties of the encasement material.

PART 2 MATERIALS**2.01 POLYETHYLENE MATERIAL**

The encasement shall consist of a polyethylene sheet or tube of at least 8 mils thickness conforming to AWWA C105.

2.02 PLASTIC ADHESIVE TAPE

Use 2-inch wide plastic adhesive tape such as Calpico Vinyl Tape, Polyken 900, Scotchwrap 50, or approved equal.

PART 3 EXECUTION**3.01 APPLYING TUBE ENCASUREMENT TO BURIED PIPE AND FITTINGS**

- A. Cut polyethylene tube 2 feet longer than the length of pipe to receive the encasement. Prior to placing the length of pipe into the trench, raise the pipe section and slip the polyethylene tube over the spigot end of the pipe. Bunch up the tube in accordion fashion between the spigot end and the supporting sling.
- B. Lower the pipe section into the trench and seat the spigot end into the bell of the previously installed pipe. Provide a shallow hole at the bell to facilitate the joint overlap.

- C. Remove the sling from the pipe. Raise the pipe from the bell end about 3 or 4-inches and slip the bunched up polyethylene tube along the full length of pipe. Leave 1-foot of bunched up polyethylene tube at each end of the pipe for joint overlap.
- D. To make the joint overlap, pull the polyethylene tube from the bell end over the pipe joint to the spigot end. Fold the tube around the pipe and secure with three circumferential wraps of 2-inch wide plastic adhesive tape or a plastic tie strap. Then pull the bunched up polyethylene tube on the spigot end over the wrapped pipe joint to the bell end. Fold tube and secure with tape as previously described or a plastic tie strap.
- E. Pull the loose polyethylene tube on the pipe snugly around the pipe barrel. Fold the excess material over at the top of pipe and secure the fold with 6-inch long strips of 2-inch wide plastic adhesive tape at 3 feet on center.
- F. Polyethylene sheet will not be allowed as a substitute for tube when required for installation on buried pipe.

3.02 APPLYING SHEET ENCASEMENT TO BURIED VALVES

Wrap valves by pulling the bunched up polyethylene tube (where installed) from the adjacent pipe over the bells or flanges of the valve. Secure the tube to the valve body with 2-inch wide plastic adhesive strips wrapped around the valve body. Then wrap the valve with a flat sheet of polyethylene. Place the sheet under the valve and fold in half. Extend the sheet to the valve stem and secure the sheet in place with 2-inch wide plastic adhesive tape. Apply the second layer and secure with tape. Secure the sheets with tape around the valve stem below the operating nut and around the barrel of the connecting pipe to prevent the entrance of soil. Pour concrete anchor and support blocks after the wrap has been properly placed.

3.03 APPLYING SHEET ENCASEMENT TO BURIED FITTINGS, COUPLINGS, AND APPURTENANCES

- A. Wrap buried ferrous metal pipe fittings, couplings, adapters, and appurtenances with polyethylene sheet. Overlap the adjoining pipe or fitting a minimum of one-foot and secure in place with 2-inch wide plastic adhesive tape. Apply a second layer and secure with tape around the barrel of the connecting pipe to prevent the entrance of soil. Pour concrete anchor and thrust blocks after the wrap has been properly placed.
- B. Wrap base elbows and risers of hydrants and backflow prevention assemblies with 2 layers of polyethylene sheet and secure in place with 2-inch wide plastic adhesive tape. Extend the wrap to the finish ground level of the assembly. Secure the sheets with tape around the ends to prevent the entrance of soil. Pour concrete anchor and support blocks after the wrap has been properly placed.

3.04 REPAIR OF POLYETHYLENE MATERIAL

Repair polyethylene material that is damaged during construction. Use polyethylene sheet, place over damaged or torn area, and secure in place with 2-inch wide plastic adhesive tape.

END OF SECTION 09954

SECTION 09961

FUSION-BONDED EPOXY LINING AND COATING

PART 1 GENERAL

1.01 DESCRIPTION

This section includes materials, application, and testing of one part, fusion-bonded, heat cured, thermosetting, 100% solids epoxy lining and coating on steel, cast iron, and ductile iron equipment, such as valves, flexible pipe couplings, fittings, structural steel, and steel pipe. Do not apply fusion-bonded epoxy to aluminum, brass, bronze, copper, plastic, rubber, or stainless steel surfaces.

1.02 RELATED WORK SPECIFIED ELSEWEHRE

RMWD Standard Drawings

1.03 SUBMITTALS

Contractor shall furnish submittals in accordance with the requirements of Section 1 – General Conditions. The following submittals are required:

- A. Submit a chart of the manufacturer's available colors for color selection well in advance of painting operation.
- B. Submit manufacturer's catalog literature and product data sheets, describing the physical and chemical properties of the epoxy coating. Describe application and curing procedure.
- C. Submit coating application test records for measuring coating thickness and holiday detection for each item or pipe section and fitting. Describe repair procedures used.

PART 2 MATERIALS

2.01 PIPING AND EQUIPMENT SURFACES

The Contractor shall require the suppliers to provide bare pipe and equipment that is free of salts, oil, and grease to the coating applicator.

2.02 SHOP APPLIED EPOXY LINING AND COATING

Lining and coating shall be a 100% solids, thermosetting, fusion-bonded, dry powder epoxy resin. Provide: Scotchkote 134 or 206N, Lilly Powder Coatings "Pipeclad 1500 Red," H.B. Fuller 1F-3003, or approved equal. Epoxy lining and coating shall meet or exceed the following requirements:

Hardness (Minimum)	Barcol 17 (ASTM D 2583) Rockwell 50 ("M" Scale)
Abrasion Resistance (Minimum)	1,000 cycles: 0.05 gram removed 5,000 cycles: 0.115 gram removed ASTM D 1044, Tabor CS 17 wheel, 1,000 gram weight

Adhesion (Minimum)	3,000 psi (Elcometer)
Tensile Strength	7,300 psi (ASTM D 2370)
Penetration	0 mil (ASTM G 17)
Adhesion Overlap Shear, 1/8-inch steel panel, 0.010 glue line	4,300 psi (ASTM D 1002)
Impact (Minimum Value)	100 inch-pounds (Gardner 5/8-inch diameter tup)

2.03 FIELD APPLIED EPOXY COATING FOR PATCHING

Use a two-component, 80% solids, liquid resin, such as Scotchkote 306 or approved equal.

PART 3 EXECUTION

3.01 GENERAL - SHOP APPLICATION OF FUSION-BONDED EPOXY

- A. Grind surface irregularities, welds, and weld spatter smooth before applying the epoxy. The allowable grind area shall not exceed 0.25 square foot per location, and the maximum total grind area shall not exceed 1 square foot per item or piece of equipment. Do not use any item, pipe, or piece of equipment in which these requirements cannot be met.
- B. Remove surface imperfections, such as slivers, scales, burrs, weld spatter, and gouges. Grind outside sharp corners, such as the outside edges of flanges, to a minimum radius of 1/4-inch.
- C. Uniformly preheat the pipe, item, or piece of equipment prior to blast cleaning to remove moisture from the surface. The preheat shall be sufficient to ensure that the surface temperature is at least 5°F above the dew point temperature during blast cleaning and inspection.
- D. Sandblast surfaces per SSPC SP-5. Protect beveled pipe ends from the abrasive blast cleaning.
- E. Apply a phosphoric acid wash to the pipe, item, or piece of equipment after sandblasting. The average temperature, measured in three different locations, shall be 80°F to 130°F during the acid wash procedure. The acid wash shall be 5% by weight phosphoric acid solution. The duration in which the acid is in contact with the surface shall be determined by using the average temperature as tabulated below:

Pipe Temperature (°F)	Contact Time (seconds)
80	52
85	45
90	36
95	33
100	28
105	24
110	21
130	10

After the acid wash has been completed, remove the acid with demineralized water having a maximum conductivity of 5 micromhos/cm at a minimum nozzle pressure of 2,500 psi.

- F. Apply lining and coating by the electrostatic spray or fluidized bed process. Minimum thickness of lining or coating shall be 12 mils. Heat and cure per the epoxy manufacturer's recommendations. The heat source shall not leave a residue or contaminant on the metal surface. Do not allow oxidation of surfaces to occur prior to coating. Do not permit surfaces to flash rust before coating.

3.02 SHOP APPLICATION OF FUSION-BONDED EPOXY TO PIPE

- A. In addition to the above requirements, apply lining and coating per AWWA C213 except as modified herein.
- B. Grind 0.020-inch (minimum) off the weld caps on the pipe weld seams before beginning the surface preparation and heating of the pipe.

3.03 QUALITY OF LINING AND COATING APPLICATIONS

The cured lining or coating shall be smooth and glossy, with no graininess or roughness. The lining or coating shall have no blisters, cracks, bubbles, underfilm voids, mechanical damage, discontinuities, or holidays.

3.04 GENERAL - SHOP TESTING OF LINING AND COATING

- A. Test linings and coatings with a low-voltage wet sponge holiday detector in accordance with AWWA C213. If the number of holidays or pinholes for flat or smooth surfaces such as pipe is fewer than one per 10 square feet of coating surface, repair and retest. If the number of holidays or pinholes for valves, couplings, and fittings, 12 inches and smaller, is 5 or less per item, repair and retest. Repair the holidays and pinholes by applying the coating manufacturer's recommended patching compound to each holiday or pinhole and retest. If the number of holidays or pinholes exceeds these allowable quantities, remove the entire lining or coating and recoat the pipe or item and retest.
- B. Measure the coating thickness at three locations on each item or piece of equipment or pipe section using a coating thickness gauge calibrated at least once per eight-hour shift.

Record each measured thickness value. Where individual measured thickness values are less than the specified minimum thickness, measure the coating thickness at three additional points around the defective area. The average of these measurements shall exceed the specified minimum thickness value, and no individual thickness value shall be more than 2 mils below or 3 mils above the specified minimum value. If a section of the pipe, item, or piece of equipment does not meet these criteria, remove the entire lining or coating and recoat the entire item or piece of equipment.

- C. The District's Representative will conduct in the field an independent inspection of the lining and coating for compliance with the above criteria. Coated items failing his inspection will be cause for rejection.

3.05 SHOP TESTING OF LINING AND COATING OF PIPE

In addition to the above requirements, check for coating defects on the weld seam centerlines. There shall be no porous blisters, craters, or pimples lying along the peak of the weld crown.

3.06 FIELD REPAIRS

Patch scratches and damaged areas incurred while installing fusion bonded epoxy coated items with a two-component, 80% solids (minimum), liquid epoxy resin. Wire brush or sandblast the damaged areas per SSPC SP-10. Lightly abrade or sandblast the lining or coating on the sides of the damaged area before applying the liquid epoxy coating. Apply a two-part epoxy coating to damaged linings and coatings to areas smaller than 20 square inches. Patched areas shall overlap the parent or base coating a minimum of 1/2-inch. If a damaged area exceeds 20 square inches, remove the entire lining and coating and recoat the entire item or piece of equipment and retest. Apply the liquid epoxy coating to a minimum dry-film thickness of 12 mils.

END OF SECTION 09961

SECTION 13110**CORROSION CONTROL FOR BURIED PIPING****PART 1 GENERAL****1.01 SCOPE**

This specification section addresses the materials, installation and testing for basic corrosion control and monitoring facilities required on most buried metallic piping. The corrosion control facilities include in this specification section are: corrosion test stations, joint bonding, insulating flange kits, casing test stations, wire and cable, exothermic welds, and simple sacrificial anode installations. Large piping projects or projects requiring large sacrificial anode or impressed current cathodic protection systems will require more detailed drawings and specifications.

1.02 REFERENCE STANDARDS

The publications listed below form a part of this specification to the extent referenced. The publications are referred to in the text by the basic designations only.

ANSI B16.21.92	Nonmetallic Flat Gaskets for Pipe Flanges
ASTM C94-81	Ready -Mix Concrete
ASTM D1248-89	Polyethylene Plastics Molding and Extrusion Materials
ASTM D2220-80	Polyvinylchloride Insulation for Wire and Cable, 75° Operation
AWWA C217-90	Cold-Applied Petrolatum Tape and Petroleum Wax Tape Coatings for the Exterior of Special Sections, Connections, and Fittings for Buried Steel Water Pipelines
NACE SP0169-07	Standard Practice, Control of External Corrosion on Underground or Submerged Metallic Piping Systems
NACE SP0286-07	Standard Practice; Electrical Isolation of Cathodically Protected Pipelines
NEMA LI-1-1983	Industrial Laminate Thermosetting Products
MIL-C-18480B	Coating Compound, Bituminous, Solvent, Coal Tar Base
UL 83-98	Thermoplastic-Insulated Wires
UL 486-00	Wire Connectors and Soldering Lugs for Use with Copper Conductors

1.03 RELATED WORK SPECIFIED ELSEWHERE

RMWD	Standard Drawings CP-1 through CP-17
RMWD	Standard Specifications and Drawings
Project Specific	Cathodic Protection Specifications and Drawings
Section 02223	Trenching, Backfilling, and Compacting
Section 03300	Cast-in-Place Concrete
Section 15056	Ductile Iron Pipe and Fittings
Section 15076	CML&C Steel Pipe

1.04 SUBMITTALS

- A. Submit shop drawings in accordance with RMWD Standard Specifications.
- B. Submit five (5) copies of manufacturer's catalog data and descriptive literature for all material items listed below and included in the project. Show dimensions and materials of construction by specification reference and grade where applicable.

1.05 DUCTILE IRON PIPE ENCASEMENT

- A. Unless otherwise specified all ductile iron pipe shall be fully encased in 8 mil (0.008 inches) polyethylene sheet material in accordance with AWWA C105 Method A and STD SPEC 15056. The plastic encasement shall be installed without pinholes or tears and shall be fully protected from damage during backfilling. All pipe sections shall be fully inspected by the Engineering Manager before the pipe is backfilled.

B. ZINC AND EPOXY COATING

In lieu of polyethylene protective wrapping, ductile iron pipe shall have 1 mil of zinc applied to its exterior in accordance with EN 545/ISO 2531. Zinc shall be applied to achieve a man mass of 130g/m² min (with local minimum of 110g/m²). A 3 mil epoxy coating shall be applied over the zinc deposit to provide mechanical protection of the zinc. This epoxy shall be provided in a color suitable for identifying the pipe for its intended application (i.e. blue = potable water). All fittings and angle points must be wrapped with polyethylene protective wrapping. **Prior approval from the Engineering Manager is required for zinc and epoxy use.**

PART 2 MATERIALS**2.01 TEST STATIONS****A. At-Grade Test Station:**

- Concrete Box: At-grade test boxes shall be round, pre-cast concrete with dimensions of 13-1/2-inch O.D. by 8-inch I.D. by 12-inches high, similar to Christy G5 Utility Box with a cast iron supporting ring and lid, and shall have sufficient strength to support occasional H-20 vehicular traffic. The lid shall be 10-inches O.D. and cast with the legend "CP Test" using letters not less than 1-1/2-inch high.

2. Concrete Pad: Test boxes mounted in un-paved areas shall be mounted in a reinforced 26-inches square by 4-inches thick concrete pad constructed of ASTM C94 Ready-Mix concrete. Rebar shall be No. 4. A concrete pad is not required where the test box is placed in pavement.
3. Brass Tags: Wire identification tags shall be 1½-inch diameter, 18 Ga. brass discs with a 3/16-inch diameter hole and die stamped with ¼-inch characters. Tags shall be attached to test wires with un-insulated AWG No. 14 solid copper wire. Tag legend shall be as indicated in the project drawings or RMWD Standard Drawings.
4. Marker Post: See paragraph 2.01 B. 4.

B. Post Mounted Test Station:

1. Enclosure: Post-mounted enclosures shall be constructed of one piece molded fiberglass and conform to NEMA 4X. The enclosure shall have a hinged cover with quick-release lockable latches and a seamless foam gasket. All hardware shall be stainless steel. Hinges shall be corrosion resistance polyester or stainless steel piano hinge. Size as follows unless specified differently in the project drawings:

<u>No. of Wires</u>	<u>Size (inside)</u>	<u>Acceptable Product</u>
2 or 3 wires	5.5x4.0x5.0"	Hoffman A-645JFGQRR
4 or 5 wires	7.5x6.0x5.28"	Hoffman A-865JFGQRR

2. Panel: The mounting panel shall be fiberglass, micarta or laminated phenolic sheet cross-laminated for resistance to warpage and weathering. Minimum panel thickness shall be 3/16-inch. Panel shall be mounted off of the back of the enclosure to allow sufficient access to make up wire terminals.
3. Components: All terminal lugs shall be solid brass. Provide a properly sized terminal lug for all wires. See RMWD Standard Drawings or Cathodic Protection Detail Drawings for wiring configuration and wire labels.
4. Post: Post shall be seasoned, construction heart garden grade redwood, 4-inches by 4-inches by 5-feet long, and surfaced on four sides. Cut a ¾-inch chamfer in all 4 top edges. Paint post with 2 coats of epoxy. Color shall be white as approved by the District.
5. Conduit: 2-inch diameter galvanized rigid steel conduit per UL 6 approximately 4-feet long with long radius sweeps. Fittings shall be galvanized rigid steel per UL 514.
6. Brass Tags: See paragraph 2.01.A.3.
7. Concrete Base: ASTM C-94 ready mix concrete.

2.02 PREPACKAGED MAGNESIUM ANODES

- A. Magnesium Anode (High Potential): unless otherwise specified anodes shall be high potential prepackaged magnesium alloy ingot of the following chemical composition:

Aluminum	0.010%
Manganese	0.50 to 1.30%
Copper	0.02% MAX
Nickel	0.001% MAX
Iron	0.03% MAX
Other	0.05% Each or 0.3% MAX Total
Magnesium	Remainder

Magnesium Anode (Standard Potential): If the Project Design Documents call out standard potential magnesium anodes the ingot shall have the following chemical composition:

Aluminum	5.3 to 6.7%
Manganese	0.15 to 0.70%
Zinc	2.5 to 3.5%
Copper	0.02% MAX
Nickel	0.002% MAX
Iron	0.003% MAX
Silicon	0.10% MAX
Other	0.05% Each or 0.3% MAX Total
Magnesium	Remainder

- B. Anode Weight: Unless otherwise specified the ingot weight of prepackaged magnesium anodes shall be 48 pounds. The anode ingot shall have a trapezoidal cross section and be approximately 32-inches long. Other anode ingot weights (with different cross sections and dimensions, typically 32 or 17 pounds) may be specified in the Projects Design Documents.
- C. Anode Backfill: Each magnesium anode shall be prepackaged in a permeable cloth bag with a backfill of the following composition:

Gypsum	75%
Powdered Bentonite	20%
Anhydrous Sodium Sulfate	5%

- D. Backfill grains shall be capable of 100% passing through a 100-mesh screen. The backfill shall be firmly packed around the anode by mechanical vibration to a density, which will maintain the magnesium ingot in the center of the cloth bag and surrounded by at least one inch of backfill.
- E. Prepackage Weight: The total packaged weight of 48-pound (ingot weight) magnesium anodes and backfill shall be approximately 105 pounds. The cloth bag diameter shall be

8-inches. The packaged weight and diameter of other anode sizes shall be as indicated in the RMWD Standard Drawings.

- F. Anode Lead Wire: Unless otherwise indicated, anode lead wire shall be AWG No. 12 stranded copper wire with THWN insulation conforming to UL Standard 83. Wire shall be connected to the strap core with silver solder. The connection shall be mechanically secured before soldering and shall have at least one and one-half (1.5) turns of wire at the connection. The connection shall then be insulated by filling the remainder of the recess with electrical potting compound. Anode lead wire shall be of sufficient length to extend from the anode to the designated termination point without a splice. Wires with cut or damaged insulation will not be accepted and replacement of the entire lead will be required at the Contractor's expense.

2.03 SHUNTS

Shunts used in the anode test boxes shall be 0.01 ohms - resistance and rated at 6 amperes capacity and accurate to plus or minus 1%. Use Holloway Type RS shunt unless otherwise specified.

2.04 WIRE AND CABLE

- A. General: All DC wires shall be stranded copper with high molecular weight polyethylene (HMWPE) or thermal plastic (THWN) insulation suitable for direct burial in corrosive soil and water conforming to UL 83 and ASTM Standards B3 or B8. HMWPE insulation shall conform to the requirements of ASTM D1248 Type 1, Class C. THWN insulation shall conform to the requirements of ASTM D-2220. Wires with cut or damaged insulation will not be accepted and replacement of the entire length of wire will be required at the Contractor's expense.
- B. Test Leads: Unless otherwise indicated, test wires shall be AWG No. 8 HMWPE wire. THWN wire shall be used only where specifically called out. Each test lead shall be of sufficient length to extend from the attachment to the pipe or structure to the test box without a splice.
- C. Bond Wires: Bond wires shall be AWG No. 2, No. 4, or No. 6 HMWPE depending on the pipe diameter and as indicated in the RMWD Standard Drawings or directed by the Engineering Manager. Bond wires shall be as short as possible.

2.05 LEAD WIRE CONNECTORS

- A. Terminal Lugs: Terminal lugs shall be solder-less, UL 486 copper or brass and sized to accommodate the wire.
- B. Split-bolt Connectors: Split bolt connectors shall be UL 486 copper or brass and sized to accommodate the lead wire and shunt being used.

2.06 INSULATING FLANGE KITS

- A. General: Insulating flange kits shall consist of Type E, full-face gaskets, insulating sleeves and double washers (steel and dielectric) on each end. All insulating material shall be of the type designated by the manufacturer as suitable for the operating temperature and pressure of the service.

- B. Gaskets: Unless otherwise indicated, insulating gaskets shall be dielectric neoprene-faced phenolic. Note that the sealing surfaces of both flanges must be compatible with the gasket.
- C. Sleeves: Use full-length sleeves except for installation on threaded studs where half-length sleeves are required. For installation on threaded bolts, i.e., at butterfly valve flange bonnets and bases, the sleeves shall be half-length. Use 1/32-inch thick G10 epoxy glass tube material as per NEMA LI-1 unless directed otherwise by the District.
- D. Washers: Insulating washers shall be 1/8-inch thick G10 epoxy glass sheet material per NEMA LI-1.
- E. Steel Washers: Steel washers shall be 1/8-inch thick cadmium plated or zinc plated carbon steel.

2.07 PIPELINE CASING INSULATORS

- A. Body: The casing insulator body shall be constructed of a 12-inch wide steel band with a heat-fused plastic (PVC) coating with a minimum thickness of 10 mils. The steel band shall be flanged with stainless steel tightening bolts and nuts. The body shall be provided with a ribbed PVC liner to protect the pipe coating and prevent slippage.
- B. Runners: 2-inch wide reinforced plastic (18,000 psi compressive strength). Runners are attached with stainless steel nuts on 3/8-inch threaded studs that are welded to the steel band before coating. The bolt holes shall be counterbored and filled with epoxy.
- C. Acceptable Products: Use PSI Model A12G-2 or equal. Wooden skids or high-density polyethylene casing insulators are not acceptable.

2.08 CASING END SEALS

- A. Type: End seals shall be either a heat shrinkable sleeve type or the mechanical link type. End seals shall provide full dielectric isolation and a watertight seal between the casing and the carrier pipes. Pre-molded casing seals held in place by an external band of metal or other material are not acceptable.
- B. Heat Shrinkable Seal: Heat shrinkable sleeve shall have a minimum tensile strength of 2,500 psi and be resistant to abrasion, corrosive gases and be able to tolerate typical expansion and contraction of the casing and carrier pipes. Provide a separate non-conductive support skirt or transition padding that will allow a smooth transition of the heat shrink material from casing to carrier diameter. Watertight seals on both the casing and the carrier pipes are required. Use Raychem Caseal or Canusa CSK Casing Seal Kit.
- C. Mechanical Link Seal: Articulated mechanical annular seal shall include EPDM rubber seal elements, non-metallic pressure plates and Type 316b stainless steel nuts and bolts for tightening. When compressed a full watertight seal is required. Use link-Seal Model "C" or District approved equivalent.

2.09 WAX TAPE WRAP

- A. Surfaces Requiring Wax Tape: All buried piping system surfaces not coated with the primary pipe coating such as flanges, valves, couplings, insulating flanges, adapters, uncoated pipe spools or specialty fittings.
- B. Material and Application Standard: Petrolatum wax tape coating system per AWWA C217.
- C. Primer: The flange and bolt surfaces shall be prime coated with a blend of petrolatum, plasticizer, inert fillers, and corrosion inhibitor having a paste-like consistency. The primer shall be Trenton Wax-Tape Primer, Denso Paste, or equivalent.
- D. Wax Tape: Flange covering material shall be a synthetic felt tape saturated with a blend of petrolatum, plasticizers, and corrosion inhibitors that is easily formable over irregular surfaces. A compatible petrolatum filler shall be used to smooth over irregular surfaces. The Wax-Tape shall be Trenton #1 Wax-Tape, Densyl Tape wrap, or District approved equivalent.
- E. Outer Covering: The primed and wax-tape wrapped flange shall be wrapped with a plastic tape covering consisting of three (3) layers of 1.5 mil, polyvinylidene chloride or PVC, high cling, conformable membranes The outer covering shall be Trenton Poly-Ply, Denso Poly-Wrap or equivalent.

2.10 EXOTHERMIC WELD KITS AND WELD COATING

- A. Weld Kits: Wire-to-pipe connections shall be made by the exothermic welding process. Weld charges and mold size shall be as specified by the manufacturer for various pipe sizes and surface configurations. Weld charges for use on cast and ductile iron are different from those used on steel. Care shall be taken during installation to be sure correct charges are used. Welding charges and molds shall be the product of a manufacturer regularly engaged in the production of such materials. Weld charges for steel pipelines shall have green caps and weld charges for cast or ductile iron shall have orange caps.
- B. Weld Cap Primer: Weld cap primer shall be an elastomer-resin based corrosion resistant primer for underground services such as Royston Roybond Primer 747 or District approved equal.
- C. Weld Caps: Exothermic welds shall be sealed with a pre-fabricated plastic cap filled with formable mastic compound on a base of elastomeric tape. Weld caps shall be Royston Handy Cap 2 or District approved equal.
- D. Weld Cap Overcoating: Weld caps and the surrounding area shall be overcoated with a cold-applied, black, thixotropic material containing plasticized coal tar pitch, solvents, and special fillers per MIL-C-18480A such as Protecto Wrap 160/160H, or Tape-Coat TC Mastic. Apply to at least 20 mils thickness.

2.11 PLASTIC WARNING TAPE

Plastic warning tape for all horizontal cable trench runs shall be a minimum of 4 mils thick and 6-inches wide, inert plastic film designed for prolonged use underground. The tape shall have

the words "Caution: Cathodic Protection Cable Below" or similar, clearly visible along its entire length.

2.12 MORTAR

Mortar used to repair concrete coated pipe after attachment of bond or pipe test lead wires shall be the fast drying, non-shrinkable type.

2.13 BARRIER POSTS

Where indicated protective barrier post shall be 6-inch SCH 40 steel pipe concrete filled. Pipe height, 3-feet by 3-inches, embedded depth 4-feet by 3-inches in a concrete footing. Paint OSHA safety yellow epoxy or as indicated.

PART 3 EXECUTION

3.01 GENERAL

Except as directed differently below, the installation of corrosion control and monitoring facilities shall conform to NACE Publication SP-0169 (Revised 2007) - Recommended Practice, Control of External Corrosion on Underground and Submerged Metallic Piping Systems and NACE SP-0286 Electrical Isolation of Cathodically Protected Pipelines. The installation of impressed current cathodic protection facilities and large sacrificial anode systems is not included in this document.

3.02 TEST BOXES

A. At-Grade Test Boxes:

1. **Location:** The at-grade test boxes shall be installed directly over the pipeline if possible. If the pipeline is in a paved roadway install behind the curb and out of traffic lanes. Test boxes can be embedded in the sidewalk just beyond the curb or placed in a concrete pad in the planter strip or just beyond the sidewalk. The Engineering Manager shall approve test station locations.
2. **Installation:** Mount test box flush with pavement or 1-inch higher than grade in grass or landscaped areas with the concrete pad domed to make a smooth transition to grade at the perimeter of the pad. The bottom of the box shall be native soil. Do not place rock, gravel or cement inside the box. All wires shall be properly identified with brass tags and cut off such that there is approximately 18-inches of slack wire above finish grade and coiled inside the test box. Keep the inside of the test box clear of all debris and other foreign material.
3. **Wire Identification:** Brass identification tags shall be securely attached to each of the wires in the test box. Tags shall be stamped in ¼-inch characters with RMWD and the size-material-service of the pipe to which the test leads are attached. For example RMWD 18"-STL-PW. Brass tags on wires in insulating flange test boxes shall be stamped with the additional identification of "N", "S", "E", or "W" for North, South, East or West to indicate on which side of the insulating flange the wires are attached. Attach tags with bare No. 14 copper wire.

4. **Concrete Pad:** In unpaved areas the test box shall be mounted in a reinforced concrete pad 26-inches square by 4-inches deep constructed of ASTM C94 Ready-Mix concrete. Rebar shall be No. 4 steel placed as shown in the drawings.
5. **Marker Posts:** Redwood marker posts are required wherever at-grade anode test boxes are utilized in a remote area. Paint the post with two (2) coats of white epoxy. Locate marker post within 6-inches of the test box or as directed by the Engineering Manager. On the side facing of the at-grade test box, stencil on the post in 2-inch high black letters the words "CP TEST".

B. Post Mounted Test Boxes:

1. **Location:** locate redwood post directly above the pipeline, if possible, but not in a roadway or in a location that clearly obstructs existing access or is particularly susceptible to damage. The Engineering Manager shall approve test station locations.
2. **Post and Footing:** Excavate a 12-inch diameter by 20-inch deep hole. Center the post and test box in the hole and fill the hole with concrete. The post shall be true vertical. The concrete shall be class C. Dome concrete slightly to prevent ponding water next to wood post.
3. **Test Box and Conduit:** Connect 2-inch galvanized conduit to the test box enclosure with a threaded flange and collar connection. Attach test box to the redwood post using mounting brackets and threaded fasteners or wood screws through the back of the test box. Attach conduit to the post with conduit clamps and wood screws if necessary. Insert all test leads in the galvanized conduit and run into test box prior to setting the post in concrete.
4. **Wire Identification:** Brass identification tags shall be installed and marked per paragraph 3.02.A.3.

3.03 INSTALLING MAGNESIUM ANODES

- A. **General:** Anodes shall be installed at locations as shown on the Drawings or as directed by the Engineering Manager. Care shall be taken to ensure that the cloth bag is not damaged and no backfill material lost during installation. Each magnesium anode shall be centered in the cloth bag. It may be necessary to re-center the anode in the cloth bag by rolling it on the ground prior to installation. Each magnesium anode shall be lowered into the hole using a sling or rope and placed vertically at the bottom of the hole. Do not lower, transport, handle or lift the anode by the lead wire.
- B. **Primary Excavation Method:** Prepackaged magnesium anodes shall be installed in a vertical augured hole of 12-inches in diameter. The depth of the hole shall be 12 feet as measured from the finish surface to the bottom of the anode unless otherwise specified by the Engineering Manager.
- C. **Alternate Excavation Method:** If the 12 foot depth cannot be obtained or if vertical auguring cannot be accomplished due to heavy rock, the Engineering Manager shall be notified for possible adjustment to the designed depth, position, and orientation of the anodes. Backhoe excavations must be approved by the Engineering Manager.

- D. **Relative Position:** In general, anodes shall be offset from the steel pipe as far as possible while staying within the District's right-of-way. A minimum offset of 10 feet shall be used unless otherwise indicated on the Corrosion Protection Detail Drawings or directed by the Engineering Manager. At no time shall an anode be installed outside of the pipeline right-of-way or District's easement. Anodes shall not be installed such that a foreign metallic pipe is between the protected pipe and the anode.
- E. **Anode Soaking (Augured Holes):** Once the prepackaged anode is in the hole, water shall be poured into the hole so that the anode is completely covered with water. Allow to soak for at least 15 minutes. Stone-free native soil shall then be used to backfill the anode hole. Do not use imported sand for backfilling. The anode hole shall be backfilled in stages and carefully tamped to ensure that no voids exist around the bag and that the bag and anode lead wire is not damaged. After backfill is level with the top of the anode, a minimum of 15 gallons of water shall be poured into the hole to completely saturate the soil backfill. More water shall be added if it is suspected that the backfill is not completely saturated. Care must be taken to avoid damage to the anode and anode lead wire.
- F. **Anode Soaking (Backhoe Installations):** Prepackaged must be pre-soaked in water for at least 15 minutes before installing in the trench. After covering the anode with native, rock-free soil (approximately 3-inches over the anode) the anode and initial backfill shall be further soaked with 15 to 20 gallons of water and allowed to soak for 15 minutes. The remainder of the trench shall be backfilled with native soil.
- G. **Wire Tags:** Anode wires are not tagged.

3.04 INSTALLING ANODE LEAD WIRES

- A. **Lead Wire:** Anode lead wire shall be long enough to reach from the anode to the anode test box without a splice. Anode lead wires shall terminate individually in the appropriate anode test box. Care shall be taken not to damage the lead wire through the installation process.
- B. **Wire Trenching:** See paragraph 3.06.D. If anode wire insulation is damaged during installation, the wire and anode shall be replaced unless wire splices or insulation repairs are approved by the Engineering Manager. Anode replacement shall be at the Contractor's expense.
- C. **Wire Splicing and Insulation Repairs:** See paragraph 3.07 for general wire splice and insulation repair requirements. Neither splices nor insulation repairs shall be allowed unless specifically approved by the Engineering Manager.

3.05 EARTHWORK

See Specification Section 02223 for earthwork requirements.

3.06 WIRE AND CABLE

- A. **General:** No less than two (2) test wires shall be attached to the pipe at each designated test site. All test wires shall terminate in a test box without a splice. A minimum of 18-inches of slack wire shall be coiled at the wire-to-pipe connection and in

at-grade test boxes for each test wire. At post-mounted test stations slack wire shall be provided inside the box to the extent possible and with one 8-inch diameter loop at the below-grade entrance to the conduit.

- B. Connection to Pipe:** Connections of copper wire to the pipeline shall be made with exothermic weld charges or by brazing. Welding charges shall be the product of a manufacturer regularly engaged in the manufacture of the material. Manufacturer's recommend cartridge size and type shall be used. Each weld shall be installed, tested and coated as described below.
1. **Preparation of Wire:** Use a cutter to prevent deforming wire ends. Remove only enough insulation from the wire to allow the weld connection to be made. Do not use a hacksaw for cutting.
 2. **Preparation of Metal:** Remove all coating, dirt, grime and grease from the metal pipe at weld location by wire brushing and/or use of suitable safe solvents. Clean the pipe to a bright, shiny surface free of all serious pits and flaws by use of mechanical grinder or a file. The area of the pipe where the attachment shall be made must be absolutely dry. Failure to provide a dry surface for welding will result in a poor quality weld and could result in serious injury to the workman. Do not cut reinforcing rods when preparing metal surface for wire attachment.
 3. **Attachment of Wire to Pipe:** The attachment of copper wire shall be made using an exothermic weld as shown on the Standard Drawings. The wire shall be held at 30° to 45° angle to the surface when welding. Only one (1) wire shall be attached with each weld.
 4. **Testing of All Completed Welds:** As soon as the weld has cooled, the weldment shall be tested for strength by striking a sharp blow with a two-pound hammer while pulling firmly on the wire. All unsound welds are to be re-welded and re-tested. All weld slag shall be removed from the weldment.
 5. **Coating of All Completed Welds:** Thoroughly clean by wire brushing the area to be coated. The area must be completely dry. Apply the weld cap primer and the weld cap. Overcoat the weld cap with a bituminous mastic coating material in accordance with the manufacturer's recommendations. Completely coat the weld, all bare pipe surfaces around the weld and any exposed copper wire. Allow sufficient time to dry prior to repair of the mortar coating on steel pipe.
 6. **Mortar Repair:** On mortar coated pipe, the mortar coating shall be repaired after the bituminous weld coating has dried, using fast-setting, non-shrinkable mortar to restore the original outside diameter of the pipe at each weld location.
- C. Plastic Lined Pipe:** Do not weld test or bond wires directly to plastic lined pipe (sewer or reclaimed water). Wires must be attached to factory installed bonding pads per RMWD Standard Drawings.
- D. Wire Trenching and Backfill:**
1. **Depth:** All buried horizontal test or anode lead runs shall be installed at a minimum depth of 24-inches.

2. **Backfill:** The bottom 2-inches of the finished trench shall be sand or stone-free earth. The first 3-inches of the backfill shall be sand or stone-free earth placed directly on the wires. The remainder of the trench shall be backfilled with native earth with a maximum stone size of 2-inches and compacted as specified in Standard Specification 02223.
3. **Damaged Wire:** Care shall be taken when installing wire and backfilling trench so that insulation is not broken, cut, nicked, or bruised. If wire insulation is damaged during installation, it shall be replaced completely at the Contractor's expense.
4. **Warning Tape:** Plastic warning tape shall be installed over all wire runs 12-inches below grade.

E. Wire Splices or Repairs

1. **Approval:** No wire splices or insulation repairs shall be made unless approved by the Engineering Manager.
2. **Splices:** The minimum amount of insulation shall be removed from each wire end. Brass crimp or split-bolt connectors shall be used. The splice shall be encased in a plastic mold filled with insulating resin such as 3M Scotchcast splice kits.
3. **Insulating Repairs:** Depending on the severity of the insulation damage repairs shall be made with electrical tape or with a splice kit as determined by the Engineering Manager.
4. **Inspection:** All splices and insulation repairs shall be inspected by the Engineering Manager before they are buried.

3.07 CONTINUITY BONDING:

- A. **General:** All joints on buried steel pipe shall be metallically continuous by welding or bonding. DIP joints may also be bonded if directed by the Project Documents or the Engineering Manager. Joints to be bonded include all unwelded pipe joints and mechanical joints including flanges (except insulating flanges), valves, couplings, adapters and special fittings. All bonding shall be done with single conductor, stranded copper jumper wires with HMWPE insulation. Bond wires shall be as short as possible with only minimal slack. All pipe reaches with one or more unwelded joints (or one or more bonds) will be tested for continuity.
- B. **Pipe Joints:** At least two (2) wires are required for each steel or ductile iron pipe bond. Two (2) wires shall be installed unless otherwise specified. Three (3) wires may be required at valves, couplings, special fittings and across unwelded joints on pipe larger than 24-inches. Bond wire sizes may be No. 2, 4 or 6. Use No. 4 bond wires unless indicated otherwise in the project drawings.
- C. **Mechanical Joints and Fittings:** All flanges and in-line fittings (valves, couplings, etc.) shall be completely bridged by at least two (2) bond wires. Three (3) wires may be required on fittings larger than 24-inches. One additional No. 6 HMWPE wire is required from the pipe (on either side) to the fitting. Bond wire sizes may be No. 2, 4 or 6. Use No. 4 bond wires unless indicated otherwise in the project drawings.

- D. Wire Attachment Method: Bond wire attachment, testing and subsequent coating of the welds shall be as specified in paragraph 3.06.B.
- E. Wire Attachment Location: Bond wires can either be attached to the pipe or pipe cylinder directly to the outside edges of flanges that are welded to the pipe. Bond wires shall not be attached to valve bodies, but instead to the flange of the valve.

3.08 INSULATING FLANGE KITS

- A. Flange Kits: Insulating kits shall be installed as shown on drawings and as recommended by the manufacturer. Moisture, soil, or other foreign matter must be carefully prevented from contacting any portion of the mating surfaces prior to installing insulator gasket. If moisture, soil, or other foreign matter contacts any portion of these surfaces, the entire joint shall be disassembled, cleaned with a suitable solvent and dried prior to reassembly.
- B. Spool Assembly: All direct buried insulating kits, greater than 20-inches in diameter, shall be pre-installed and tested on the pipe spool prior to installing the spool in the ditch. If possible, all smaller size direct buried insulating kits shall be similarly pre-installed and tested.
- C. Handling of Gasket: Care shall be taken to prevent any excessive bending or flexing of the gasket. Creased or damaged gaskets shall be rejected and removed from the job site.
- D. Alignment: Alignment pins shall be used to properly align the flange and gasket.
- E. Bolt Tightening: The manufacturer's recommended bolt-tightening sequence shall be followed. Bolt insulating sleeves shall be centered within the insulation washers so that the insulating sleeve is not compressed and damaged.
- F. Testing: All insulating flanges must be tested by a qualified Corrosion Technician or Engineer and accepted by the Engineering Manager. All buried insulating flanges must be tested prior to wax tape wrap coating and backfilling. The assembled flange shall be tested as described below.
- G. Wax Tape Coating: After testing and the Engineering Manager's acceptance, the insulating flange shall be fully wrapped with petrolatum wax tape as indicated in this specification section.

3.09 SUPPLEMENTARY INTERIOR LINING AT INSULATING FLANGES

- A. General: Supplementary linings are required **only** where called out in the drawings or Project Design Documents. It is the contractor's responsibility to determine and verify which insulating flanges require supplementary internal lining.
- B. Extent of lining: the interior of the pipeline shall be lined with a supplementary epoxy lining for a distance of two (2) pipe diameters in each direction away from an insulating flange. At an insulated flange on a valve, the supplementary lining shall be applied (for a distance of two pipe diameters) only to the pipe directly adjacent to the insulating flange.

- C. **Surface Preparation:** The surface preparation of the mortar lining shall consist of wire brushing (hand or power) or water blasting to remove the latence and all loose mortar to provide a clean abraded surface for adhesion of the lining. The surface shall be clean and free of dust and standing water but not necessarily dry.
- D. **Mixing:** The two-part epoxy paint shall be thoroughly mixed per the manufacturer's recommendations but at a minimum of two (2) minutes by hand or with a mechanical mixer before being applied by brush.
- E. **Pot Life:** A typical pot life is 30 minutes. The lining material shall not be applied after its useful pot life.
- F. **Application:** Application of undiluted lining material shall be by spray, roller or brush until a maximum coating thickness of 20 mils is achieved. Each ensuing coat shall be applied before the previous coat fully cures, usually within 3 to 6 hours. Typically, this material is applied at the rate of 140 square feet per gallon. This would ordinarily produce the required coating with a total of two (2) coats. However, the 20-mil minimum thickness shall be satisfied regardless of the number of applications necessary to achieve it.
- G. **Inspection:** Each pipe spool to which the supplementary lining is applied must be inspected and accepted by the Engineering Manager prior to assembly.

3.10 CASING INSTALLATIONS

- A. **Casing Insulators:** The number and orientation of runners on each casing insulator shall be as recommended by the manufacturer depending on pipe size. The spacing between insulators shall be determined by the civil or structural engineer.
- B. **End Seals:** Heat shrinkable or mechanical link seals shall be installed in accordance with the manufacturer's recommendations. Remove all contaminants and debris from the annulus. Seals must be watertight.
- C. **Casing Test Stations:** Test stations (4-wire) shall be installed on all casings. Use two (2) each No. 10 HMWPE wires on the casing and two (2) each No. 8 HMWPE wires on the carrier pipe unless otherwise directed. Use post-mounted or at-grade test stations as indicted in the project drawings or as directed by the Engineering Manager.

3.11 EARTHWORK

See Specification 02223 for earthwork requirements.

PART 4 SYSTEM TESTING

4.01 TEST LEADS AND BOND WIRES

- A. **Responsibility:** The Contractor shall be responsible for testing all test leads and bond wire welds.
- B. **Test Method:** All completed wire connection welds shall be tested for strength by striking the weld with a sharp blow with a 2-pound hammer while pulling firmly on the wire. Welds failing this test shall be re-welded and re-tested. Wire welds shall be spot

tested by the Engineering Manager. After backfilling pipe, all test lead pairs shall be tested using a standard ohmmeter or resistance meter for broken welds. Bond wires shall be tested through continuity testing described below.

- C. Acceptance: The resistance between each pair of test leads shall not exceed 150% of the total wire resistance as determined from calculations based on published wire resistance data and an estimate of test wire length.

4.02 ANODE INSTALLATIONS

- A. Responsibility: The contractor must provide the proper rated potential anode, sufficient anode lead wire length and the proper anode hole depth. The Engineering Manager shall test each installed anode for wire connection integrity and for open-circuit potential.
- B. Notification: The Contractor shall notify the Engineering Manager at least five (5) days in advance of the start and completion of the anode installations, including anodes and test stations.
- C. Cathodic Protection Performance Test Method: The performance of the cathodic protection system shall be tested by the District Corrosion Engineer. The testing shall include: measurement of all open-circuit anode potentials; pipe-to-soil potentials at each test station and other locations as necessary before the anodes are connected; initial anode currents after connecting anode leads to the pipe leads; and the pipe-to-soil potential at each previously tested site with all anodes connected. Pre- and post cathodic protection potentials at midpoints between anode beds are required as necessary to verify that the pipeline is fully protected. Adequate protection shall be as defined in NACE SP-0169.
- D. Field Report: All system deficiencies shall be listed and described in one or more field test reports and presented to the Contractor for repairs.
- E. Acceptance: The system will be accepted if all anodes, test stations, and supporting facilities are installed properly. Cathodic protection performance, with the exception of materials and installation deficiencies, is not the Contractor's responsibility.

4.03 WIRE TRENCHING

- A. Responsibility: The Engineering Manager, at his or her discretion, shall inspect wire trenches and backfill material and methods.
- B. Test Method: The depth, trench bottom padding and backfill material shall be visually inspected prior to backfilling.
- C. Acceptance: Conformance with project specifications.

4.04 INSULATOR TESTING

- A. Responsibility: Insulating flanges shall be inspected and tested by the District Corrosion Engineer or Corrosion Technician. Buried insulators must be tested and approved prior to application of wax tape and backfilling. Large diameter insulators shall be tested on the spool prior to installation in the ditch.

- B. **Test Method:** The assembled flange shall be tested with an insulator testing device (i.e., Gas Electronics Model 601 Insulation Checker) specifically designed for this purpose. Additionally, the pipe-to-soil potential, using a high impedance voltmeter and suitable reference cell, shall be measured on each side of the insulator after installation in the trench but before backfilling. Potential testing can only be done on piping that has been installed in the ditch.
- C. **Acceptance:** The installation shall be considered complete when the insulator testing device indicates that no shorts or partial shorts are present and when the potential tests indicate greater than 20-millivolt pipe-to-soil potential difference across the flange. (Note that this test may not be valid if the pipe on each side of the insulator is in contact through interconnection piping or through contacts to the electrical grounding system.) If shorts are detected the Contractor shall assist the Engineering Manager in finding partial shorts or shorted bolts. All disassembly and re-assembly necessary to gain approval from the Engineering Manager shall be done at the Contractor's expense.

4.05 PIPELINE CONTINUITY

- A. **Responsibility:** The District's Corrosion Engineer shall test the continuity of all sections of buried steel pipe that contains non-welded pipe joints or mechanical joints or fittings. All such joints are required to be bonded per this specification. Bonded DIP also requires continuity testing.
- B. **Test Method:** Resistance shall be measured by the linear resistance method. A direct current shall be impressed from one end of the test section to the other (test station to test station) using DC power supply (battery). A voltage drop is measured with the direct current applied. The resistance (R) is calculated using the equation $R = dV/I$, where dV is the voltage drop and I is the current.
- C. **Acceptance:** Acceptance is reasonable comparison of the measured resistance with the calculated or theoretical resistance. The measured resistance shall not exceed the theoretical resistance by more than 30%. The Contractor shall submit calculations of the theoretical resistance and the measured resistance for each section of pipe tested.
- D. **Deficiencies:** If discontinuity or high resistance is found between sections of pipe tested, it is the Contractor's responsibility to locate, excavate, and repair all bonds that are found to be discontinuous. Continuity tests shall be repeated after repairs are made. **Note:** Discontinuities may be difficult and expensive to locate and may require several excavations to expose pipe joints and attach temporary test leads for progressive continuity testing. Accordingly, the Contractor shall exercise due care in installing continuity bonds and shall schedule continuity testing as early as possible so that discontinuity location and repairs, if necessary, do not conflict with road paving operations.

4.06 TEST STATIONS

- A. **Responsibility:** The Engineering Manager will inspect all test station installations for compliance with this specification. The Engineering Manager will test all wires for continuity and proper connection.
- B. **Test Method:** Test stations will be visually inspected. Wire continuity will be tested by potential and resistance measurements.

- C. Acceptance: Installation in accordance with this specification and good workmanship and verification that all wires are properly connected.

4.07 WAX TAPE COATING

- A. Responsibility: The Engineering Manager shall inspect all completed wax tape wrapping for compliance with these specifications prior to backfilling.
- B. Test Method: Inspection shall be visual.
- C. Wax Tape Acceptance: Wax tape applications shall be accepted if: the application conforms with this specification; there are no voids or gaps under the wax tape; stud-ends, nuts, couplings rods and all irregular surfaces are individually wrapped such that there is complete coverage with the petrolatum material; the outer wrap is complete and tightly adhering to the wax tape; and the application is done in a good workman-like manner.
- D. Supplementary Lining Acceptance: Internal supplementary linings must cover the specified length of pipe and must be well bonded to the substrate and free of voids or damage.

4.08 CASING ISOLATION

- A. Responsibility. The Engineering Manager shall test the isolation between the carrier pipe and the casing and verify that there is no metallic contact between the two structures.
- B. Method. Two test methods are required. Structure-to-soil potentials of each structure shall differ by more than 30 millivolts with the reference cell located in the same place. Resistance between the two structures, measured with a megger or other suitable resistance meter, shall exceed 25 ohms. Additional or alternate test methods recommended by the Contractor shall be approved by the Engineering Manager.
- C. Notification for Testing. The Contractor shall notify the Engineering Manager at least five (5) days in advance of plans to test isolation between the carrier pipe and the casing.
- D. Acceptance. Complete metallic isolation is required. Under no conditions will a metallic short between the carrier pipe and the casing be allowed.

4.09 DEFICIENCIES

Deficiencies: Any deficiencies or omissions in materials or workmanship found by these tests shall be rectified by the Contractor at his expense. Deficiencies shall include but are not limited to: broken or missing test leads; improper or unclean wire trench backfill; inadequate pipeline continuity; shorted or partially shorted insulators or casings; lack of 18-inch slack wire in at-grade test boxes; improperly mounted or located test boxes; improper wire identification; poorly applied wax tape or supplementary lining; and other deficiencies associated with the workmanship, installation and non-functioning equipment.

END OF SECTION 13110

SECTION 13200**FACTORY-BUILT PRESSURE REGULATING STATION****PART 1 GENERAL****1.01 DESCRIPTION – SCOPE OF WORK**

- A. The contractor shall furnish and install one (1) - above-ground pressure regulating station, factory built, factory delivered, with all necessary internal piping, valves, fittings, supports, control valves, meter and other necessary appurtenances as shown on the plans and specified herein.
- B. The station shall be complete when delivered and will not require internal contractor construction except to install the power service, if required, through the service conduit provided for that purpose and to connect the main water service to the required points and other work as may be listed in the Section for CONTRACTORS INSTALLATION REQUIREMENTS.

1.02 CONTRACTOR INSTALLATION REQUIREMENTS

The contractor shall be required to offload the station and set the station on the foundation designed by the engineer shown in the plan set. The foundation shall be built by the contractor and as directed by the engineer. Following setting of the station, the contractor will be required to anchor the station to the foundation. The contractor shall supply the anchor bolts.

1.03 CONTRACTORS RECOGNITION OF A VALID EQUIPMENT PROPOSAL

- A. To avoid a displacing of responsibility, the Pressure Regulating Station manufacturer alone shall propose to contractors on the assembled equipment covered by this section of these contract documents. Said manufacturer's proposal must be signed by an officer of the manufacturing company.
- B. Bidding Contractors are instructed NOT to accept or base their bid on equipment proposals from a representative, third party agent or intermediary.
- C. The Contractors shall provide electronically to the Engineer of Record an un-priced Equipment Proposal from any proposing manufacturers, doing so to ensure those proposals are direct from and signed by each proposing manufacturer.

1.04 MANUFACTURER'S RESPONSIBILITY FOR PERFORMANCE

The Specifications and Drawings for the Factory-built equipment do not necessarily include all the details for the design and fabrication for the factory-built equipment. The Drawings are generally schematic but the specifications do call out strict requirements to known methods, components and assemblies that must be in a full, complete and functional Pressure Regulating Station. As such, the Manufacturer shall accept and hold complete responsibility for the functionality of the Pressure Regulating Station and its workings.

1.05 SPECIFIED MANUFACTURER

The equipment specified and shown shall be manufactured and provided by Engineered Fluid, Inc. as equipment standard to the Owner so as to match performance and serviceability of equipment in the system and currently in operation. This equipment is offered by Dale Huntington, of Huntington & Associates at 760-751-2278.

1.06 SUBMITTAL

- A. Equipment submittals shall be bound and in a minimum of two (2) hard paper copy bound and two (2) electronic copies on CD. The submittals shall contain a minimum of two (2) full size drawings, size 24" x 36"; one (1) each covering the pressure regulating station and the electrical control schematic. The pressure regulating station drawing shall be specific to this project, in at least three (3) different views, be to scale and illustrate the National Electrical Code (NEC) clearances per Section 110-26 of the Code. The submittal booklets will be complete with data sheets covering all major components that make up the pressure regulating station and the UL/ETL file number under which the manufacturer is listed, service department personnel statement as detailed in the specifications and be complete with the manufacturer's formal warranty policy. **The submittal booklets shall be complete with a full size photocopy of the manufacturer's combination UL/manufacturer logo Packaged Pumping Systems label.**
- B. Two (2) submittal reviews of this item will be accomplished at no cost to the submitting contractor. However, all subsequent reviews will be charged to the submitting contractor at the design engineer's standard hourly billing rate.

1.07 QUALITY ASSURANCE

The equipment furnished shall be designed, constructed, and installed in accordance with the best practices and methods and shall operate satisfactorily when installed as shown on the contract drawings and operated per manufacturer's recommendations.

1.08 THIRD PARTY INSPECTION LISTING

The station manufacturer shall be required to affix to the station an UNDERWRITERS LABORATORIES (UL) LABEL attesting to the compliance of the station equipment under the PACKAGED PUMPING SYSTEMS (QCZJ) UL Listing Category and/or INTERTEK TESTING SERVICES (ETL) LABEL attesting to the compliance of the station equipment under PACKAGED PUMPING SYSTEMS. The ETL label shall state the station conforms to UL STD 778 and is certified to CAN/CSA STD C22.2 NO. 108.

1.09 SHIPPING AND DELIVERY

- A. The specified equipment shall be delivered by the manufacturer FOB DESTINATION and thereby the station manufacturer shall hold the full responsibility for the condition and completeness of the equipment upon its delivery.

- B. The Engineering Manager shall hold the right to inspect the equipment prior to unloading and setting so as to assure the quality and condition of the equipment is in no way deficient.
- C. If in the view of the Engineering Manager, the equipment is deficient when delivered, delivery shall be refused.

1.10 SPECIFIED COMPONENTS

Within the body of this specification and on the drawings, certain components are listed by name and/or model number for at least One (1) manufacturer's specific product. As such, no "OR EQUAL" is listed or allowed where at least the one manufacturer is listed. These listed components have been chosen because of the Engineering Manager's and Owner's knowledge of and experience with these listed components. No other components other than those listed are acceptable.

1.11 FACTORY START-UP AND TRAINING SERVICE

- A. Without exception, the station manufacturer is directly responsible for station start-up and operator training. Third party contractors, agents or representatives are not to be allowed to start up the station nor the equipment therein. As such;
 - 1. Start-up Factory Service Technician shall be a regular employee of the station manufacturer.
 - 2. The manufacturer shall provide two (2) copies of the complete Operation & Maintenance Manual in electronic form.

1.12 MANUFACTURER'S WARRANTY

- A. The warranty is the sole responsibility of the station manufacturer and that manufacturer's warranty shall be provided in written form, being placed in both the Submittal documents covering the specified equipment and the O&M manuals provided with that equipment.
- B. It is required the station warranty provide the Owner with a single source responsibility for all components specified herein and the system as a whole. That single source shall be none other than the station manufacturer. Third party suppliers, service contractors, "Pass-through" warranties and service by the representative are not acceptable.
- C. Said manufacturer's warranty shall at a minimum cover:
 - 1. A period of one (1) year commencing upon successful start-up, after authorized manufacturer's start-up, not to exceed eighteen (18) months from the date of shipment.
 - 2. The warranty period shall be inviolate regardless of any component manufacturer's warranty for equipment and components within the station.
 - 3. The manufacturer's warranty shall cover all equipment, components and systems

provided in or with the station by the manufacturer of the station, exclusive of those components supplied by and/or installed by others independent of the manufacturer of record for this station.

4. The warranty shall provide for the station manufacturer to bear the full cost of labor and materials for replacement and/or repair of faulty or defective components so there shall be no cost incurred by the Owner for this work during the warranty period.
5. The manufacturer's warranty policy is amended only by the items considered consumable, i.e., light bulbs, lubricants and other maintenance items consumed by usage.
6. No assumption of contingent liabilities for any component failure during manufacturer's warranty is made.
7. The warranty pertains only where the equipment has been operated in strict accordance with the manufacturer's instructions and requirements. Evidence of misuse or modification to the equipment voids the warranty.

If the submitted written manufacturer's warranty does not meet the minimum requirements set forth above, that submittal will forthrightly be rejected.

1.13 GENERAL LIABILITY INSURANCE

- A. The pressure regulating station manufacturer shall furnish premises/operations and products/completed operations general liability insurance from an insurance company with a rating of A-V according to the most recent Best's Key Rating Guide, in an amount equal to \$10,000,000 per occurrence.
- B. The insurance certificate must be included with the manufacturer's submittal. The coverage must be provided by an insurance carrier licensed and admitted in the state of manufacture.

PART 2 PRODUCTS AND COMPONENTS

2.01 TILT-BACK, ON GRADE EQUIPMENT COVER AND BASE

The pressure reducing valves and related equipment shall be provided complete to the jobsite ready for connection of the inlet and outlet piping and electrical connection. The station shall be made of a steel welded base and tilt-back fiberglass covers.

2.02 TILT-BACK EQUIPMENT BASE

- A. The equipment base shall be one completed unit when delivered. Field welding to complete the structure or attach the internal piping system will not be acceptable.
- B. The steel plate and structural shapes used must be adequate to meet the purpose for which they are intended plus the additional stresses from the lifting and setting of the

equipment. The equipment base design shall accommodate both lifting from above the unit by a hoist or crane and lifting from below by a fork lift.

- C. The plate steel employed throughout the equipment base shall meet or exceed the requirements for ASTM A-36. The structural shapes (channels and angles) shall be of the thickness/weight as shown on the plans for this item and shall meet or exceed the requirements for ASTM A-36. The design of all members shall be in accordance with the recommended practice for design as specified in the MANUAL OF STEEL CONSTRUCTION, published by the American Institute of Steel Construction, Inc.

2.03 TILT-BACK EQUIPMENT COVER

- A. The equipment enclosure shall be a hand layup, molded fiberglass cover of the size and shape shown. The cover shall match the size of the equipment base so to overlap the edges of the Equipment Base when lowered over it.
- B. The Equipment Cover shall contain the following elements in its fabrication:
1. Resins - Resins shall be thermosetting, medium reactivity, rigid fire resistant polyester containing maximum monomer content of 42% and a maximum of 11% Thixotropic additive.
 2. Glass Fiber - Glass Fiber reinforcement shall be K filament type E Borosilicate glass having high performance chrome-complex or silane finish compatible with polyester resins.
 3. Gelcoat - Exterior surface coating shall be ultraviolet light stabilized, weather resistant, polyester base containing fade resistant color pigments, and such inert extenders as are appropriate to maintain total pigment volume concentration less than 20%.
 4. Interior Coating - Interior laminate coating when required shall be a pigmented heat resistant high gloss polyester base surfacing sealer.
- C. The equipment cover shall be attached to the Equipment Base by hinges at one end. A minimum of three (3) butt type hinges shall be used and each hinge will have a removable hinge pin. The hinges will be affixed to the cover by bolting and be complete with a full span aluminum backing bar. Bolts and nuts of the hinging system will not directly bear on the fiberglass cover, but bear only on each hinge and the backing bar. The hinges will allow the cover to open fully to expose all interior equipment.
- D. Two (2) inert gas over oil spring-loaded opening assist automatic cylinders shall be attached to each equipment cover and the equipment base to counterbalance the weight of the fiberglass cover and ease the opening and closing function. The cylinders shall have an internal orifice controlled valve that dampens the extension motion but that permits un-dampened compression.
- E. The equipment cover shall be secured from unauthorized entry by a simplex, weather resistant padlock system. Where more than one (1) cover is used or more than one (1)

station is supplied, the padlocks will be keyed alike. Two (2) keys will be provided for each padlock, with each set of keys on a key ring complete with the manufacturer's identification and service telephone number.

- F. The Equipment Cover shall be complete with a minimum of one (1) galvanized lifting handle. The handle will be affixed to the long side of the cover. The handle will be so located as to allow the equipment enclosure cover to be easily tilted to expose completely the mechanical/electrical equipment contained therein. The handle will be bolted through the cover and through an aluminum backing bar.

2.04 FLOORDRAINS

The station shall have 2 floor drains in opposing corners as shown on the drawing. The floor drains shall be a 2" grated opening with 2" I.D threaded hub for connection of a drain line up under the station floor.

2.05 PIPING-TRANSMISSION

- A. The piping shall conform to AWWA Standard C-200.
- B. Piping shall be steel and conform to material specification ASTM A-53(CW) for nominal pipe size four (4) inch and smaller and ASTM A-53(ERW) Grade B for nominal pipe size five (5) inches and larger. Steel butt-welding fittings shall conform to material specification ASTM A-234 Grade WPB and to the dimensions and tolerances of ANSI Standards B16.9 and B16.28 respectively.
- C. Forged steel flanges shall conform to material specification ASTM A-105 Class 60 and/or ASTM A-181 for carbon steel forgings and to the dimensions and tolerances of ANSI Standards B16.5 as amended in 1992 for Class 150 and Class 300 flanges.
- D. The piping sizes shall be as shown on the drawing.
Size 10-inch and below - Schedule 40
Size 12-inch thru 20-inch - Standard weight (.375" wall)

2.06 PIPE WELDING

- A. All pipe welds shall be performed by certified welders employed by the pressure regulating station manufacturer. As part of the equipment submittal, the station manufacturer shall provide copies of the welding certificates of the employees who are to perform the pipe welds.
- B. Shop welders shall be certified in accordance with ASME BPVC Section IX or AWS D1.1. Certification shall be done by an independent testing laboratory giving certification for the weld positions for which the tests were performed.

2.07 PIPE SURFACE PREPARATION

All piping inside and outside surfaces shall be prepared by grit blasting, or other abrasive blasting, prior to any welds taking place to minimum SP-6 finish.

2.08 PIPE CUTTING

- A. Piping of 4" diameter and smaller may be cut by saw.
- B. Piping of 6" diameter and larger shall be bevel cut, and Oxyfuel or Plasma-arc cutting techniques shall be used to assure and facilitate bevel pipe cuts.

2.09 SADDLE CUTS AND WELDS

- A. Saddle cuts in pipe made in preparation for a saddle weld of a pipe at an angle to a pipe shall be made with numerically controlled, plasma cutting machines. Similarly, saddle end cuts to pipes to make a saddle mating piece shall be done with the same numerically controlled plasma cutting equipment.
- B. When the two saddle cut pieces are mated and welded with the MIG process, the internal finished weld shall be smooth and free of inclusions, crevices and other corrosion sites.

2.10 PIPE WELDING TECHNIQUES

- A. Pipe welds shall be performed by metal added, inert gas shielded arc welding (MIG) techniques wherein the weld heat settings, the wire feed speed and the traverse speed of the work below the welding are numerically set to assure proper weld fusion and penetration and repeatable welds.
- B. In all cases, short circuit transfer, spray transfer or pulse-arc transfer modes of the gas metal arc welding process shall be used.
- C. When utilizing the short circuit mode, shielding gas consisting of 50% carbon dioxide and 50% argon gas shall be used. When utilizing the spray or pulse-arc transfer modes, a shielding gas consisting of 5% carbon dioxide and 95% argon shall be used.
- D. In all cases, welding wire with a minimum tensile strength of 70,000 psi shall be employed.
- E. All flange welds and butt welds of equal size pipe shall be a single continuous nonstop weld around the complete circumference of the pipe. Whenever possible, vertical up weld passes will be applied to all pipe welds. No vertical down weld passes will be allowed.
- F. Completed pipe welded assemblies shall create no internal obstruction, restriction or create any unintended sources of water deflection.
- G. Piping of 6-inch diameter and larger shall require a minimum of two (2) weld passes to complete each weld. The first pass, or root pass, shall be applied at the bottom of the bevel cut using the short circuit transfer welding mode, and the second pass, or cap pass, shall be applied over the root pass using the spray or pulse arc transfer welding modes to insure that at a minimum the total weld thickness shall be equal to thinnest of

the two pieces being welded together.

- H. The pipe shall be sand blasted, as specified elsewhere, before pipe weld and after pipe weld, before fusion bonded epoxy is applied.

2.11 WELD STANDOFFS

- A. No welding shall be performed on fusion bonded coated piping after the coating process has been performed.
- B. Where any piping is to be welded after the application of fusion bonded epoxy coating to the inside of the pipe, at the point of the weld, a weld standoff must be welded to the pipe prior to the coating. The weld shall be made to the standoff and not onto the pipe.

2.12 FLOOR/WALL PENETRATION COATING PROTECTION SLEEVE

- A. Where a fusion bonded epoxy interior coated pipe passes through the steel base, prior to fusion bonded coating of that pipe, a pipe sleeve shall be welded over the pipe in the area where the pipe passes through the steel sheet.
- B. The sleeve shall be one-half (1/2") inch thickness and fit closely over the transmission pipe. The sleeve shall be seal welded to the transmission pipe at each end with a full and continuous fillet weld.
- C. Following the welding of the sleeve to the transmission piping, the sleeve welds and the sleeve shall be grit blasted to an SP-6 finish so the pipe is prepared for fusion bonded epoxy coating by the process specified elsewhere in these documents.

2.13 PIPE SUPPORTS

- A. Pipe supports by minimum sizing for:
 - 1. 8" and smaller piping shall be 2" x 3" x 3/16" wall rectangular tubing;
 - 2. 10" and larger piping shall be 3" x 4" x 1/4" wall rectangular tubing;
- B. Pipe supports are to be fully welded at both end points to the pipe and steel floor where required.
- C. Where components are to be supported and may require disassembly at some time, the supports for these components shall be welded at the bottom and bolted at the top by use of a bolt yoke welded to the top of the support and bolted into the flange connection picking up at least three bolts.

2.14 FUSION BONDED EPOXY INTERNAL PIPE COATING

- A. The internal surfaces of piping to be fusion bonded coated shall be grit blasted to an SP-10 finish with the finish profile required by the coating material manufacturer.

- B. The internal, wetted surfaces of the steel transmission piping shall have applied to it a Fusion Bonded Epoxy Coating on the interior pipe surface. The coating shall be applied and meet the testing requirements of Table 1 and Table 2 with the exception of Table 2 section 7 per AWWA C-213.
- C. The powder coating product shall be National Sanitation Foundation (NSF) Standard 61 certified material.
- D. The epoxy powder coating shall be Powdura NSF-61 ELS8-80003 from Sherwin Williams.
- E. Prior to shipment of the station, the station manufacturer shall provide in writing to the Engineer certification that the fusion bonded epoxy coating has been applied to all internal surfaces of the steel piping using the proper method. Said certification shall show under the station manufacturer's letterhead:
 - 1. Date of application;
 - 2. Material manufacturer and product designation including a product data sheet for the coating;
 - 3. Applier of the fusion bonded coating, name, address and phone number;
 - 4. Notarized signature of an officer of the station manufacturing company stating the fusion bonded epoxy coating was applied to AWWA Standard C213-91 or the latest revision.

2.15 COATINGS - CORROSION PROTECTION

- A. All interior and exterior surfaces of the exposed steel structure, transmission piping, and fittings shall be grit blasted equal to commercial blast cleaning (SSPC-SP6). Following fabrication all exposed surfaces of the station, interior and exterior shall be coated according to the following requirements.
- B. Weldment Prime Coating: All weldments will be pretreated by hand to provide additional corrosion protection using the same product as the base coat. Following the pretreatment full coating application shall take place.
- C. Base Coating: The base coating shall take place immediately after surface preparation. The protective coating shall consist of a two-component, high solids, high build, fast drying epoxy system for protection and finishing of steel and having excellent corrosion resistant properties. The epoxy system shall be self-priming and require no intermediate coatings.
- D. Top Coating: Following the base coating application, a full finish coating application shall take place. The protective coating shall consist of a two-component, high solids, high build, fast drying epoxy system for protection and finishing of steel and having excellent corrosion resistant properties. The epoxy system shall be self-priming and require no intermediate coatings. The base and finish coats shall provide a total dry mil

thickness of 8.0 mils.

- E. Post-Assembly Coating: Following assembly and just prior to shipping, there shall take place a thorough cleaning of the floor of the station followed by a rolled on coating of the two part epoxy coating to cover over any scuffing or scaring that might have occurred during assembly.

2.16 SERVICE CONNECTIONS ON INTERNAL PIPING

All plumbed devices within the station eventually requiring service, such as meters, control valves, shall be easily removed from the piping by the presence of appropriately placed and sufficient quantity of adaptors and couplings as shown on the drawings; no less than the quantity of couplings and adaptors shown shall be allowed.

2.17 RESTRAINING POINTS

The main inlet and outlet piping to the station shall each be provided with two (2) or four (4) restraining points as welded on "eyes" or similar device welded to the underside/wall of the base as shown to facilitate the attachment of joint restraint tie rods or other device to be used in retarding any pipe movement at the connections.

2.18 COMPRESSION COUPLINGS

- A. The station piping shall include a variety of compression type, flexible coupling to prevent binding and facilitate removal of associated equipment. These couplings are to be where shown on the plans. In lieu of a compression coupling, a flanged coupling adapter (FCA) may be used.
- B. All compression couplings or flanged coupling adapters (FCA), and flexible connectors/expansion joints shall include a minimum of two (2) zinc coated steel threaded rods across the joint with appropriate bolted restraining points.

2.19 LINE PRESSURE GAUGES

- A. Pressure gauges shall have a built-in pressure snubber and have 4-1/2" minimum diameter faces and turret style case, black fiberglass-reinforced thermoplastic with a clear acrylic window with Buna-N gasket. The movement shall be rotary; the bourdon tube shall be copper alloy C-type. The gauge shall have a 1/4" MNPT lower mount process connection and contain a 0.6mm copper alloy restrictor. Combination pressure gauge range and scale graduations shall be in psi and feet of water as follows:
- B. Gauge ranges shall be established by the Engineer for each of the inlet and outlet gauges for each pressure regulating station. The outlet gage must have a range that will allow highest inlet pressure without over pressure occurring.
- C. All gauges will be panel mounted off the pipeline and be connected to their respective sensing point. The gauge trim tubing shall be complete with both isolating and vent valves and the tubing shall be so arranged as to easily vent air and facilitate gauge removal. Gauges mounted directly to the pipeline or at the sensing point will not be

accepted.

- D. Gauge ranges, markings and gauge location shall be identified in the submittal documents.

2.20 STATIC AND SENSING LINES

- A. All gauge, switch and transmitter sensing lines shall be minimum 1/4" OD stainless steel tubing run from the sensing point and a ball valve to the point of device mounting.
- B. The pilot tubing shall be run in a workmanlike manner with elastomeric/stainless steel mounting straps to securely hold the tubing to be free of stress and vibration. The alignment and organization of the sensing lines shall be continuously rising.

2.21 SAMPLE TAP

A single, right angle outlet, smooth nose, brass sample tap shall be affixed to the manual vent ball valve for sample tap.

2.22 HOSE BIBB WITH VACUUM BREAKER

There shall be provided a standard hose bibb with valve and vacuum breaker on the outlet piping. The hose bibb connection shall be through a pressure regulator if the outlet header pressure would exceed 60 psi.

2.23 BALL VALVE CURB STOP

- A. The valve ends shall be integral or secured with adhesive to prevent unintentional disassembly. The seats and stem O-rings shall be EPDM. The brass that comes in contact with potable water shall contain no lead and conform to AWWA C800. The ball shall be fluorocarbon-coated brass. The letters "NL" shall be cast into the main body for lead-free identification. The valves will be female iron pipe thread by female iron pipe thread. Maximum working pressure shall be 300 PSI. The valve shall be certified to NSF/ANSI Standard 61 and Standard 372. The valves shall be supplied with a handle.
- B. Valve manufacturer: Ford Meter Box model B11

2.24 ISOLATING GATE VALVE

- A. The isolating valve as shown shall be a full ported gate valve meeting the requirements of AWWA C-515. The body, bonnet, wedge and seal plate shall be ductile iron in accordance with ASTM A536. The wedge shall be totally encapsulated in EPDM rubber. The bonnet gasket, wiper ring, O-ring stem seals and O-ring gland seal shall be ASTM D2000 Buna-N nitrile rubber. All fasteners are to be 304 stainless steel. The valve shall be epoxy coated in accordance with ANSI/AWWA C550. The valve shall have NSF 61 and NSF 372 approval. The valves are to be non-rising stem with handwheel operator, opening left. The valve body shall be flanged and drilled to ANSI B16.1, Class 125 with a maximum working pressure rating of 250 psi.

- B. Valve manufacturer: AVK Series 65

2.25 HYDRAULIC ACTUATED CONTROL VALVES – PRESSURE REDUCING VALVES

- A. The valve configuration as shown shall be hydraulically operated, single diaphragm actuated. The valve shall consist of three major components: the body with seat installed, the cover with bearing installed, and the diaphragm assembly. The diaphragm assembly shall be the only moving part and shall form a sealed chamber in the upper portion of the valve, separating operating pressure from line pressure. Packing glands and/or stuffing boxes are not permitted and there shall be no pistons operating the main valve or pilot controls. Valve body and cover shall be epoxy coated and holiday tested after the coating is applied. The stainless steel seat with integral bearing shall be of the solid, one piece design.
- B. The diaphragm assembly shall contain a non-magnetic stainless steel stem of sufficient diameter to withstand high hydraulic pressures. The stem shall be fully guided through its complete stroke by a removable bearing in the valve cover and an integral bearing in the valve seat. No center guides shall be permitted. The stem shall be drilled and tapped in the cover end to receive and affix such accessories as may be deemed necessary.
- C. The flexible, non-wicking, FDA approved diaphragm shall consist of nylon fabric bonded with synthetic rubber compatible with the operating fluid. The diaphragm shall be fully supported in the valve body and cover by machined surfaces which support no less than one-half of the total surface area of the diaphragm in either the fully open or fully closed position.
- D. The pressure reducing pilot control shall be a direct-acting, adjustable, spring-loaded, normally open, diaphragm valve designed to permit flow when controlled pressure is less than the spring setting. The pilot control is held open by the force of the compression on the spring above the diaphragm and it closes when the delivery pressure acting on the underside of the diaphragm exceeds the spring setting. The pilot control system shall include a fixed orifice.
- E. A valve position indicator shall be installed on the main valve cover and shall consist of a brass indicator rod fastened to the main valve stem which moves up and down inside a clear Pyrex tube contained in a bar brass housing open on two sides to permit clear vision of the brass indicator rod.
- F. The pilot control system shall include CK2 isolation valves and "Y" strainer.
- G. The pilot system shall include an opening and closing speed control on all valves.
- H. The valve shall be equipped with a downstream pressure gauge.
- I. The Control Valve shall be a Cla-Val Model 90G-01BCSYPVKC.

2.26 HYDRAULIC ACTUATED CONTROL VALVES – PRESSURE RELIEF VALVES (WHEN APPLICABLE)

- A. The valve configuration as shown shall be hydraulically operated, single diaphragm actuated. The valve shall consist of three major components: the body with seat installed, the cover with bearing installed, and the diaphragm assembly. The diaphragm assembly shall be the only moving part and shall form a sealed chamber in the upper portion of the valve, separating operating pressure from line pressure. Packing glands and/or stuffing boxes are not permitted and there shall be no pistons operating the main valve or pilot controls. Valve body and cover shall be epoxy coated. The stainless steel seat with integral bearing shall be of the solid, one piece design.
- B. The diaphragm assembly shall contain a non-magnetic stainless steel stem of sufficient diameter to withstand high hydraulic pressures. The stem shall be fully guided through its complete stroke by a removable bearing in the valve cover and an integral bearing in the valve seat. No center guides shall be permitted. The stem shall be drilled and tapped in the cover end to receive and affix such accessories as may be deemed necessary.
- C. The flexible, non-wicking, FDA approved diaphragm shall consist of nylon fabric bonded with synthetic rubber compatible with the operating fluid. The diaphragm shall be fully supported in the valve body and cover by machined surfaces which support no less than one-half of the total surface area of the diaphragm in either the fully open or fully closed position.
- D. Pilot controlled sensing shall be upstream of the pilot system strainer so accurate control may be maintained if the strainer is partially blocked.
- E. The pressure relief pilot shall be a direct-acting, adjustable, spring-loaded, diaphragm valve designed to permit flow when controlling pressure exceeds in the adjustable spring setting. The pilot control is normally held closed by the force of the compression on the spring above the diaphragm and it opens when the pressure acting on the underside of the diaphragm exceeds the spring setting. The pressure relief valve shall be supplied with the Dura-Kleen® stem (KD option).
- F. A valve position indicator shall be installed on the main valve cover and shall consist of a brass indicator rod fastened to the main valve stem which moves up and down inside a clear Pyrex tube contained in a bar brass housing open on two sides to permit clear vision of the brass indicator rod.
- G. The pilot control system shall include CK2 isolation valves.
- H. The pilot system shall include closing speed control on all valves.
- I. The valve shall be equipped with a upstream pressure gauge.
- J. The Control Valve shall be a Cla-Val Model 50G-01BSPVKCKD.

2.27 COMBINATION AIR RELEASE/VACUUM VALVES

- A. The air release & vacuum break valve shall be of the compact single chamber design with solid cylindrical H.D.P.E. control Floats housed in a tubular Stainless Steel Body with epoxy powder coated Mild Steel or Stainless Steel ends secured by means of

Stainless Steel Tie Rods. The valve shall have an integral 'Anti-Shock' Orifice mechanism which shall operate automatically to limit transient pressure rise or shock induced by closure to 1.5 x valve rated working pressure. The intake orifice area shall be equal to the nominal size of the valve i.e., a 150mm (6") valve shall have a 150mm (6") intake orifice. Large orifice sealing shall be effected by the flat face of the control float seating against a EPDM rubber 'O' ring housed in a dovetail groove circumferentially surrounding the orifice. Discharge of pressurized air shall be controlled by the seating & unseating of a Small Orifice Nozzle on a EPDM rubber seal affixed into the control float. The Nozzle shall have a flat seating land surrounding the orifice so that the damage to the rubber seal is prevented. The valve construction shall be proportioned with regard to material strength characteristics, so that deformation, leaking or damage of any kind does not occur by submission to one and half times the designed working pressure. The valve design shall incorporate an over pressure safety feature that will fail without an explosive effect, such as is normally the case when highly compressed air is released suddenly. The feature shall consist of easily replaceable components such as Gaskets, Seals or the like. Connection to the valve inlet shall be facilitated by a screwed NPT male end.

- B. The Air Release/Vacuum Valve shall be a Vent-O-Mat Model RBX.

2.28 PRESSURE TESTING

- A. When the station plumbing is completed, the pressure piping within the station (including valves, control valves, and fittings), connections as make up the entire system shall be hydrostatically tested at a pressure of 150 psi or a pressure equal to the lowest test pressure rating of the equipment within the tested system, whichever is lesser pressure. The test pressure shall be applied for a minimum of 20 minutes, during which time all joints, connections and seams shall be checked for leaking. Any deficiencies found shall be repaired and the system shall be retested.
- B. The results of this testing shall be transmitted in writing to the Engineer prior to shipment of the station and shall note test pressure, time at full pressure and be signed by the Quality Control Manager or test technician.

2.29 TELEMETRY CONTROL INTERFACE PANEL (WHEN APPLICABLE)

- A. It will be the responsibility of the station manufacturer to provide the following as an adjunct to the supplied telemetry equipment.
1. 1" telemetry entrance conduit complete to telemetry panel.
 2. Size 12" x 12" NEMA 1 telemetry interface panel.
 3. Separate 120 volt single phase power circuit in conduit to the telemetry interface panel.
 4. Telemetry control circuits made up and in conduit from main control panel to telemetry interface panel terminal strip.
 5. Metal framing channel to mount telemetry equipment.

2.30 ELECTRICAL CONDUIT AND WIRING (WHEN APPLICABLE)

- A. All service entrance conduits power and signal, shall be rigid steel conduit, individually sized to accept the inbound service conductors and telemetry/telephone/radio cables.
- B. These service entrance conduits shall be installed from the main power or control panel through the capsule steel sidewall or the building floor and terminate exterior to the equipment enclosure as a thread hub. The service entrance exterior conduit connection points shall be capped or plugged for shipment.
- C. All wiring within the equipment enclosure and outside of the panel enclosures shall be run in conduit except where watertight flexible conduit is properly used to connect fan motors, solenoid valves, limit switches, etc., where flexible connections are best utilized.
- D. Devices and appliances where furnished by the original manufacturer and being equipped with a UL approved rubber cord and plug, may be plugged into a receptacle.
- E. Equipment enclosure conduits shall be rigid, heavy wall, Schedule 40 PVC with solvent weld moisture-proof connections, in minimum size 3/4-inch or larger, sized to handle the type, number and size of equipment conductors to be carried.
- F. The conduiting shall be in compliance with Article 347 of the National Electrical Code and NEMA TC-2, Federal WC-1094A and UL-651 Underwriters Laboratory Specifications.
- G. Where flexible conduit connections are necessary, the conduit used shall be Liquid-tight, flexible, totally nonmetallic, corrosion resistant, nonconductive, U.L. listed conduit sized to handle the type, number and size of equipment conductors to be carried - in compliance with Article 351 of the National Electrical Code.
- H. Motor circuit conductors shall be sized for load. All branch circuit conductors supplying a single motor of one (1) horsepower or more shall have an ampacity of not less than 125 percent of the motor full load current rating, dual rated type THHN/THWN, as set forth in Article 310 and 430-B of the National Electrical Code, Schedule 310-13 for flame retardant, heat resistant thermoplastic, copper conductors in a nylon or equivalent outer covering.
- I. Control and accessory wiring shall be sized for load, type MTW/AWM (Machine tool wire/appliance wiring material) as set forth in Article 310 and 670 of the National Electrical Code, Schedule 310-13 and NFPA Standard 79 for flame retardant, moisture, heat and oil resistant thermoplastic, copper conductors in compliance with NTMA and as listed by Underwriters Laboratories (AWM), except where accessories are furnished with a manufacturer supplied UL approved rubber cord and plug.

2.31 GAUGE PRESSURE TRANSMITTERS (WHEN APPLICABLE)

- A. Pressure transmitters shall be supplied to measure inlet and outlet pressure. The transmitters shall sense gauge pressure and transmit a 4-20 mA dc signal. The instruments shall measure pressure of a predetermined span. Range is to be fully adjustable throughout using allowable span and range limits. The accuracy shall be $\pm 0.20\%$ of span.
- B. Each transmitter shall provide an analog output and include a standard LCD with pushbuttons to provide Intelligent transmitter configuration directly from the on-board

pushbuttons. The two-line digital indicator shall display the measurement in any selected units. The pushbuttons shall provide calibration of zero and span, setting of linear output, forward or reverse direction, external zero enable or disable, damping, failsafe action and local display including upper and lower range value selection.

- C. All process-wetted parts of each instrument shall be Type 316L stainless steel. The transmitter shall be protected by a gasketed, weatherproof NEMA 4X enclosure. The transmitter shall be approved for use in hazardous locations (Nonincendive for Class 1 and Class II, Division 2 locations; intrinsically safe or explosion-proof for Class 1 and Class II, Division 1 locations).
- D. The transmitter shall have 1/2-inch NPT female threaded tapping ports.
- E. Gauge Pressure Transmitter manufacturer: Foxboro Series IGP10.

END OF SECTION 13200

SECTION 13250**FACTORY-BUILT METER STATION****PART 1 GENERAL****1.01 DESCRIPTION – SCOPE OF WORK**

- A. The contractor shall furnish and install one (1) - factory built, factory delivered, above-ground meter station with all necessary internal piping, valves, fittings, supports, control valves, meter and other necessary appurtenances as shown on the plans and specified herein.
- B. The station shall be complete when delivered and will not require internal contractor construction. The contractor will be required to connect the main water service to the meter station and other work as may be listed in the Section for CONTRACTORS INSTALLATION REQUIREMENTS.

1.02 CONTRACTOR INSTALLATION REQUIREMENTS

The contractor shall be required to offload the station and set the station on the foundation designed by the engineer shown in the plan set. The foundation shall be built by the contractor and as directed by the engineer. Following setting of the station, the contractor will be required to anchor the station to the foundation. The contractor shall supply the anchor bolts.

1.03 CONTRACTORS RECOGNITION OF A VALID EQUIPMENT PROPOSAL

- A. To avoid a displacing of responsibility, the Meter Station manufacturer alone shall propose to contractors on the assembled equipment covered by this section of these contract documents. Said manufacturer's proposal must be signed by an officer of the manufacturing company.
- B. Bidding Contractors are instructed NOT to accept or base their bid on equipment proposals from a representative, third party agent or intermediary.
- C. The Contractors shall provide electronically to the Engineering Manager an un-priced Equipment Proposal from any proposing manufacturers, doing so to ensure those proposals are direct from and signed by each proposing manufacturer.

1.04 MANUFACTURER'S RESPONSIBILITY FOR PERFORMANCE

The Specifications and Drawings for the Factory-built equipment do not necessarily include all the details for the design and fabrication for the factory-built equipment. The Drawings are generally schematic but the specifications do call out strict requirements to known methods, components and assemblies that must be in a full, complete and functional meter station. As such, the Manufacturer shall accept and hold complete responsibility for the functionality of the meter station and its workings.

1.05 SPECIFIED MANUFACTURER

The equipment specified and shown shall be manufactured and provided by Engineered Fluid, Inc. as equipment standard to the Owner so as to match performance and serviceability of equipment in the system and currently in operation. This equipment is offered by Mr. Dale Huntington, of Huntington & Associates at 760-751-2278.

1.06 SUBMITTAL

- A. Equipment submittals shall be bound and in a minimum of two (2) hard paper copy bound and two (2) electronic copies on CD. The submittals shall contain a minimum of two (2) full size drawings, size 24" x 36"; one (1) each covering the meter station and the electrical control schematic. The meter station drawing shall be specific to this project, in at least three (3) different views, be to scale and illustrate the National Electrical Code (NEC) clearances per Section 110-26 of the Code. The submittal booklets will be complete with data sheets covering all major components that make up the meter station and the UL/ETL file number under which the manufacturer is listed, service department personnel statement as detailed in the specifications and be complete with the manufacturer's formal warranty policy. **The submittal booklets shall be complete with a full size photocopy of the manufacturer's combination UL/manufacturer logo Packaged Pumping Systems label.**
- B. Two (2) submittal reviews of this item will be accomplished at no cost to the submitting contractor. However, all subsequent reviews will be charged to the submitting contractor at the design engineer's standard hourly billing rate.

1.07 QUALITY ASSURANCE

The equipment furnished shall be designed, constructed, and installed in accordance with the best practices and methods and shall operate satisfactorily when installed as shown on the contract drawings and operated per manufacturer's recommendations.

1.08 THIRD PARTY INSPECTION LISTING (STATIONS 600V MAX.)

The station manufacturer shall be required to affix to the station an UNDERWRITERS LABORATORIES (UL) LABEL attesting to the compliance of the station equipment under the PACKAGED PUMPING SYSTEMS (QCZJ) UL Listing Category and/or INTERTEK TESTING SERVICES (ETL) LABEL attesting to the compliance of the station equipment under PACKAGED PUMPING SYSTEMS. The ETL label shall state the station conforms to UL STD 778 and is certified to CAN/CSA STD C22.2 NO. 108.

1.09 SHIPPING AND DELIVERY

- A. The specified equipment shall be delivered by the manufacturer FOB DESTINATION and thereby the station manufacturer shall hold the full responsibility for the condition and completeness of the equipment upon its delivery.
- B. The Engineering Manager shall hold the right to inspect the equipment prior to unloading and setting so as to assure the quality and condition of the equipment is in no way deficient.
- C. If in the view of the Engineering Manager, the equipment is deficient when delivered, delivery shall be refused.

1.10 SPECIFIED COMPONENTS

- A. Within the body of this specification and on the drawings, certain components are listed by name and/or model number for at least One (1) manufacturer's specific product. As such, no "OR EQUAL" is listed or allowed where at least the one manufacturer is listed.

- B. These listed components have been chosen because of the Engineering Manager and Owner's knowledge of and experience with these listed components.
- C. No other components other than those listed are acceptable.

1.11 FACTORY START-UP AND TRAINING SERVICE

- A. Without exception, the station manufacturer is directly responsible for station start-up and operator training. Third party contractors, agents or representatives are not to be allowed to start up the station nor the equipment therein. As such;
 1. Start-up Factory Service Technician shall be a regular employee of the station manufacturer.
 2. The manufacturer shall provide two (2) copies of the complete Operation & Maintenance Manual in electronic form.

1.12 MANUFACTURER'S WARRANTY

- A. The warranty is the sole responsibility of the station manufacturer and that manufacturer's warranty shall be provided in written form, being placed in both the Submittal documents covering the specified equipment and the O&M manuals provided with that equipment.
- B. It is required the station warranty provide the Owner with a single source responsibility for all components specified herein and the system as a whole. That single source shall be none other than the station manufacturer. Third party suppliers, service contractors, "Pass-through" warranties and service by the representative are not acceptable.
- C. Said manufacturer's warranty shall at a minimum cover:
 1. A period of one (1) year commencing upon successful start-up, after authorized manufacturer's start-up, not to exceed eighteen (18) months from the date of shipment.
 2. The warranty period shall be inviolate regardless of any component manufacturer's warranty for equipment and components within the station.
 3. The manufacturer's warranty shall cover all equipment, components and systems provided in or with the station by the manufacturer of the station, exclusive of those components supplied by and/or installed by others independent of the manufacturer of record for this station.
 4. The warranty shall provide for the station manufacturer to bear the full cost of labor and materials for replacement and/or repair of faulty or defective components so there shall be no cost incurred by the Owner for this work during the warranty period.
 5. The manufacturer's warranty policy is amended only by the items considered consumable, i.e., light bulbs, lubricants and other maintenance items consumed by usage.
 6. No assumption of contingent liabilities for any component failure during manufacturer's

warranty is made.

7. The warranty pertains only where the equipment has been operated in strict accordance with the manufacturer's instructions and requirements. Evidence of misuse or modification to the equipment voids the warranty.

If the submitted written manufacturer's warranty does not meet the minimum requirements set forth above, that submittal will forthrightly be rejected.

1.13 GENERAL LIABILITY INSURANCE

- A. The water distribution station manufacturer shall furnish premises/operations and products/completed operations general liability insurance from an insurance company with a rating of A-V according to the most recent Best's Key Rating Guide, in an amount equal to \$10,000,000 per occurrence.
- B. The insurance certificate must be included with the manufacturer's submittal. The coverage must be provided by an insurance carrier licensed and admitted in the state of manufacture.

PART 2 PRODUCTS AND COMPONENTS

2.01 TILT-BACK, ON GRADE EQUIPMENT COVER AND BASE

- A. The valves, meters and related equipment shall be provided complete to the jobsite ready for connection of the inlet and outlet piping.
- B. The station shall be made of a steel welded base and tilt-back fiberglass covers.

2.02 TILT-BACK EQUIPMENT BASE

- A. The equipment base shall be one completed unit when delivered. Field welding to complete the structure or attach the internal piping system will not be acceptable.
- B. The steel plate and structural shapes used must be adequate to meet the purpose for which they are intended plus the additional stresses from the lifting and setting of the equipment. The equipment base design shall accommodate both lifting from above the unit by a hoist or crane and lifting from below by a fork lift.
- C. The plate steel employed throughout the equipment base shall meet or exceed the requirements for ASTM A-36. The structural shapes (channels and angles) shall be of the thickness/weight as shown on the plans for this item and shall meet or exceed the requirements for ASTM A-36. The design of all members shall be in accordance with the recommended practice for design as specified in the MANUAL OF STEEL CONSTRUCTION, published by the American Institute of Steel Construction, Inc.

2.03 TILT-BACK EQUIPMENT COVER

- A. The equipment enclosure shall be a hand layup, molded fiberglass cover of the size and shape shown. The cover shall match the size of the equipment base so to overlap the edges of the Equipment Base when lowered over it.

- B. The Equipment Cover shall contain the following elements in its fabrication:
1. Resins - Resins shall be thermosetting, medium reactivity, rigid fire resistant polyester containing maximum monomer content of 42% and a maximum of 11% Thixotropic additive.
 2. Glass Fiber - Glass Fiber reinforcement shall be K filament type E Borosilicate glass having high performance chrome-complex or silane finish compatible with polyester resins.
 3. Gelcoat - Exterior surface coating shall be ultraviolet light stabilized, weather resistant, polyester base containing fade resistant color pigments, and such inert extenders as are appropriate to maintain total pigment volume concentration less than 20%.
 4. Interior Coating - Interior laminate coating when required shall be a pigmented heat resistant high gloss polyester base surfacing sealer.
- C. The equipment cover shall be attached to the Equipment Base by hinges at one end. A minimum of three (3) butt type hinges shall be used and each hinge will have a removable hinge pin. The hinges will be affixed to the cover by bolting and be complete with a full span aluminum backing bar. Bolts and nuts of the hinging system will not directly bear on the fiberglass cover, but bear only on each hinge and the backing bar. The hinges will allow the cover to open fully to expose all interior equipment.
- D. Two (2) inert gas over oil spring-loaded opening assist automatic cylinders shall be attached to each equipment cover and the equipment base to counterbalance the weight of the fiberglass cover and ease the opening and closing function. The cylinders shall have an internal orifice controlled valve that dampens the extension motion but that permits un-dampened compression.
- E. The equipment cover shall be secured from unauthorized entry by a simplex, weather resistant padlock system. Where more than one (1) cover is used or more than one (1) station is supplied, the padlocks will be keyed alike. Two (2) keys will be provided for each padlock, with each set of keys on a key ring complete with the manufacturer's identification and service telephone number.
- F. The Equipment Cover shall be complete with a minimum of one (1) galvanized lifting handle. The handle will be affixed to the long side of the cover. The handle will be so located as to allow the equipment enclosure cover to be easily tilted to expose completely the mechanical/electrical equipment contained therein. The handle will be bolted through the cover and through an aluminum backing bar.

2.04 FLOORDRAINS

The station shall have 2 floor drains in opposing corners as shown on the drawing. The floor drains shall be a 2-inch grated opening with 2" I.D threaded hub for connection of a drain line up under the station floor.

2.05 PIPING-TRANSMISSION

- A. The piping shall conform to AWWA Standard C-200.

- B. Piping shall be steel and conform to material specification ASTM A-53(CW) for nominal pipe size four (4) inch and smaller and ASTM A-53(ERW) Grade B for nominal pipe size five (5) inches and larger. Steel butt-welding fittings shall conform to material specification ASTM A-234 Grade WPB and to the dimensions and tolerances of ANSI Standards B16.9 and B16.28 respectively.
- C. Forged steel flanges shall conform to material specification ASTM A-105 Class 60 and/or ASTM A-181 for carbon steel forgings and to the dimensions and tolerances of ANSI Standards B16.5 as amended in 1992 for Class 150 and Class 300 flanges.
- D. The piping sizes shall be as shown on the drawing.
 Size 10 inch and below - Schedule 40
 Size 12 inch thru 20 inch - Standard weight (.375" wall)

2.06 PIPE WELDING

- A. All pipe welds shall be performed by certified welders employed by the meter station manufacturer. As part of the equipment submittal, the station manufacturer shall provide copies of the welding certificates of the employees who are to perform the pipe welds.
- B. Shop welders shall be certified in accordance with ASME BPVC Section IX or AWS D1.1. Certification shall be done by an independent testing laboratory giving certification for the weld positions for which the tests were performed.

2.07 PIPE SURFACE PREPARATION

All piping inside and outside surfaces shall be prepared by grit blasting, or other abrasive blasting, prior to any welds taking place to minimum SP-6 finish.

2.08 PIPE CUTTING

- A. Piping of 4" diameter and smaller may be cut by saw.
- B. Piping of 6" diameter and larger shall be bevel cut, and Oxyfuel or Plasma-arc cutting techniques shall be used to assure and facilitate bevel pipe cuts.

2.09 SADDLE CUTS AND WELDS

- A. Saddle cuts in pipe made in preparation for a saddle weld of a pipe at an angle to a pipe shall be made with numerically controlled, plasma cutting machines. Similarly, saddle end cuts to pipes to make a saddle mating piece shall be done with the same numerically controlled plasma cutting equipment.
- B. When the two saddle cut pieces are mated and welded with the MIG process, the internal finished weld shall be smooth and free of inclusions, crevices and other corrosion sites.

2.10 PIPE WELDING TECHNIQUES

- A. Pipe welds shall be performed by metal added, inert gas shielded arc welding (MIG) techniques wherein the weld heat settings, the wire feed speed and the traverse speed of the

work below the welding are numerically set to assure proper weld fusion and penetration and repeatable welds.

- B. In all cases, short circuit transfer, spray transfer or pulse-arc transfer modes of the gas metal arc welding process shall be used.
- C. When utilizing the short circuit mode, shielding gas consisting of 50% carbon dioxide and 50% argon gas shall be used. When utilizing the spray or pulse-arc transfer modes, a shielding gas consisting of 5% carbon dioxide and 95% argon shall be used.
- D. In all cases, welding wire with a minimum tensile strength of 70,000 psi shall be employed.
- E. All flange welds and butt welds of equal size pipe shall be a single continuous nonstop weld around the complete circumference of the pipe. Whenever possible, vertical up weld passes will be applied to all pipe welds. No vertical down weld passes will be allowed.
- F. Completed pipe welded assemblies shall create no internal obstruction, restriction or create any unintended sources of water deflection.
- G. Piping of six (6) inch diameter and larger shall require a minimum of two (2) weld passes to complete each weld. The first pass, or root pass, shall be applied at the bottom of the bevel cut using the short circuit transfer welding mode, and the second pass, or cap pass, shall be applied over the root pass using the spray or pulse arc transfer welding modes to insure that at a minimum the total weld thickness shall be equal to thinnest of the two pieces being welded together.
- H. The pipe shall be sand blasted, as specified elsewhere, before pipe weld and after pipe weld, before fusion bonded epoxy is applied.

2.11 WELD STANDOFFS

- A. No welding shall be performed on fusion bonded coated piping after the coating process has been performed.
- B. Where any piping is to be welded after the application of fusion bonded epoxy coating to the inside of the pipe, at the point of the weld, a weld standoff must be welded to the pipe prior to the coating. The weld shall be made to the standoff and not onto the pipe.

2.12 FLOOR/WALL PENETRATION COATING PROTECTION SLEEVE

- A. Where a fusion bonded epoxy interior coated pipe passes through the steel base, prior to fusion bonded coating of that pipe, a pipe sleeve shall be welded over the pipe in the area where the pipe passes through the steel sheet.
- B. The sleeve shall be one-half (1/2") inch thickness and fit closely over the transmission pipe. The sleeve shall be seal welded to the transmission pipe at each end with a full and continuous fillet weld.
- C. Following the welding of the sleeve to the transmission piping, the sleeve welds and the sleeve shall be grit blasted to an SP-6 finish so the pipe is prepared for fusion bonded epoxy coating by the process specified elsewhere in these documents.

2.13 PIPE SUPPORTS

- A. Pipe supports by minimum sizing for:
 - 1. 8" and smaller piping shall be 2" x 3" x 3/16" wall rectangular tubing;
 - 2. 10" and larger piping shall be 3" x 4" x 1/4" wall rectangular tubing;
- B. Pipe supports are to be fully welded at both end points to the pipe and steel floor where required.
- C. Where components are to be supported and may require disassembly at some time, the supports for these components shall be welded at the bottom and bolted at the top by use of a bolt yoke welded to the top of the support and bolted into the flange connection picking up at least three bolts.

2.14 FUSION BONDED EPOXY INTERNAL PIPE COATING

- A. The internal surfaces of piping to be fusion bonded coated shall be grit blasted to an SP-10 finish with the finish profile required by the coating material manufacturer.
- B. The internal, wetted surfaces of the steel transmission piping shall have applied to it a Fusion Bonded Epoxy Coating on the interior pipe surface. The coating shall be applied and meet the testing requirements of Table 1 and Table 2 with the exception of Table 2 section 7 per AWWA C-213.
- C. The powder coating product shall be National Sanitation Foundation (NSF) Standard 61 certified material.
- D. The epoxy powder coating shall be Powdura NSF-61 ELS8-80003 from Sherwin Williams.
- E. Prior to shipment of the station, the station manufacturer shall provide in writing to the Engineer certification that the fusion bonded epoxy coating has been applied to all internal surfaces of the steel piping using the proper method. Said certification shall show under the station manufacturer's letterhead:
 - 1. Date of application;
 - 2. Material manufacturer and product designation including a product data sheet for the coating;
 - 3. Applier of the fusion bonded coating, name, address and phone number;
 - 4. Notarized signature of an officer of the station manufacturing company stating the fusion bonded epoxy coating was applied to AWWA Standard C213-91 or the latest revision.

2.15 COATINGS - CORROSION PROTECTION

- A. All interior and exterior surfaces of the exposed steel structure, transmission piping, and fittings shall be gritblasted equal to commercial blast cleaning (SSPC-SP6). Following

fabrication all exposed surfaces of the station, interior and exterior, shall be coated according to the following requirements.

- B. **Weldment Prime Coating:** All weldments will be pretreated by hand to provide additional corrosion protection using the same product as the base coat. Following the pretreatment full coating application shall take place.
- C. **Base Coating:** The base coating shall take place immediately after surface preparation. The protective coating shall consist of a two-component, high solids, high build, fast drying epoxy system for protection and finishing of steel and having excellent corrosion resistant properties. The epoxy system shall be self-priming and require no intermediate coatings.
- D. **Top Coating:** Following the base coating application, a full finish coating application shall take place. The protective coating shall consist of a two-component, high solids, high build, fast drying epoxy system for protection and finishing of steel and having excellent corrosion resistant properties. The epoxy system shall be self-priming and require no intermediate coatings. The base and finish coats shall provide a total dry mil thickness of 8.0 mils.
- E. **Post-Assembly Coating:** Following assembly and just prior to shipping, there shall take place a thorough cleaning of the floor of the station followed by a rolled on coating of the two part epoxy coating to cover over any scuffing or scaring that might have occurred during assembly.

2.16 SERVICE CONNECTIONS ON INTERNAL PIPING

All plumbed devices within the station eventually requiring service, such as meters, valves, shall be easily removed from the piping by the presence of appropriately placed and sufficient quantity of adaptors and couplings as shown on the drawings; no less than the quantity of couplings and adaptors shown shall be allowed.

2.17 RESTRAINING POINTS

The main inlet and outlet piping to the station shall each be provided with two (2) or four (4) restraining points as welded on "eyes" or similar device welded to the underside/wall of the base as shown to facilitate the attachment of joint restraint tie rods or other device to be used in retarding any pipe movement at the connections.

2.18 COMPRESSION COUPLINGS

- A. The station piping shall include a variety of compression type, flexible coupling to prevent binding and facilitate removal of associated equipment. These couplings are to be where shown on the plans. In lieu of a compression coupling, a flanged coupling adapter (FCA) may be used.
- B. All compression couplings or flanged coupling adapters (FCA), and flexible connectors/expansion joints shall include a minimum of two (2) zinc coated steel threaded rods across the joint with appropriate bolted restraining points.

2.19 LINE PRESSURE GAUGES

- A. Pressure gauges shall have a built-in pressure snubber and have 4-1/2" minimum diameter faces and turret style case, black fiberglass-reinforced thermoplastic with a clear acrylic

window with Buna-N gasket. The movement shall be rotary; the bourdon tube shall be copper alloy C-type. The gauge shall have a 1/4" MNPT lower mount process connection and contain a 0.6mm copper alloy restrictor. Pressure gauge range and scale graduations shall be in psi and feet of water as follows:

- B. Gauge ranges shall be established by the Engineer for the inlet pressure of each meter station.
- C. The gauge will be panel mounted off the pipeline and be connected to their respective sensing point. The gauge trim tubing shall be complete with both isolating and vent valves and the tubing shall be so arranged as to easily vent air and facilitate gauge removal. Gauges mounted directly to the pipeline or at the sensing point will not be accepted.
- D. Gauge ranges, markings and gauge location shall be identified in the submittal documents.

2.20 STATIC AND SENSING LINES

- A. All gauge sensing lines shall be minimum 1/4" OD stainless steel tubing run from the sensing point and a ball valve to the point of device mounting.
- B. The pilot tubing shall be run in a workmanlike manner with elastomeric/stainless steel mounting straps to securely hold the tubing to be free of stress and vibration. The alignment and organization of the sensing lines shall be continuously rising.

2.21 SAMPLE TAP

A single, right angle outlet, smooth nose, brass sample tap shall be affixed to the manual vent ball valve for sample tap.

2.22 HOSE BIBB WITH VACUUM BREAKER

There shall be provided a standard hose bibb with valve and vacuum breaker on the outlet piping. The hose bibb connection shall be through a pressure regulator if the header pressure would exceed 60 psi.

2.23 BALL VALVE CURB STOP

- A. The valve ends shall be integral or secured with adhesive to prevent unintentional disassembly. The seats and stem O-rings shall be EPDM. The brass that comes in contact with potable water shall contain no lead and conform to AWWA C800. The ball shall be fluorocarbon-coated brass. The letters "NL" shall be cast into the main body for lead-free identification. The valves will be female iron pipe thread by female iron pipe thread. Maximum working pressure shall be 300 PSI. The valve shall be certified to NSF/ANSI Standard 61 and Standard 372. The valves shall be supplied with a handle.
- B. Valve manufacturer: Ford Meter Box model B11

2.24 ISOLATING GATE VALVE

- A. The isolating valve as shown shall be a full ported gate valve meeting the requirements of

AWWA C-515. The body, bonnet, wedge and seal plate shall be ductile iron in accordance with ASTM A536. The wedge shall be totally encapsulated in EPDM rubber. The bonnet gasket, wiper ring, O-ring stem seals and O-ring gland seal shall be ASTM D2000 Buna-N nitrile rubber. All fasteners are to be 304 stainless steel. The valve shall be epoxy coated in accordance with ANSI/AWWA C550. The valve shall have NSF 61 and NSF 372 approval. The valves are to be non-rising stem with handwheel operator, opening left. The valve body shall be flanged and drilled to ANSI B16.1, Class 125 with a maximum working pressure rating of 250 psi.

- B. Valve manufacturer: AVK Series 65

2.25 WATER METER & STRAINER

- A. The meter station shall include a turbine type meter, sized as shown on the plans for this item. The turbine meter shall be flanged and shall conform to ANSI Class 125. The meter shall be provided with a lead free alloy housing and measuring chamber which shall include a thermoplastic rotor with lubricated thermoplastic radial bearings and a ceramic magnet embedded in the rear face of the rotor. The trim shall be stainless steel. A hermetically sealed direct reading register shall totalize in gallons with a 100 gallon sweep hand per revolution. Maximum operating pressure 150 psi. The turbine meter assembly shall be complete with a plate type, top clean-out strainer, and integral to the inlet of the turbine meter as shown on the plans for this item. The meter shall conform to NSF 61 and 372 standards.
- B. The Meter shall be a Badger Model Recordall® Turbo Series Meter.

2.26 COMBINATION AIR RELEASE/VACUUM VALVES (if required)

- A. The air release & vacuum break valve shall be of the compact single chamber design with solid cylindrical H.D.P.E. control Floats housed in a tubular Stainless Steel Body with epoxy powder coated Mild Steel or Stainless Steel ends secured by means of Stainless Steel Tie Rods. The valve shall have an integral 'Anti-Shock' Orifice mechanism which shall operate automatically to limit transient pressure rise or shock induced by closure to 1.5 x valve rated working pressure. The intake orifice area shall be equal to the nominal size of the valve i.e., a 150mm (6") valve shall have a 150mm (6") intake orifice. Large orifice sealing shall be effected by the flat face of the control float seating against a EPDM rubber 'O' ring housed in a dovetail groove circumferentially surrounding the orifice. Discharge of pressurized air shall be controlled by the seating & unseating of a Small Orifice Nozzle on a EPDM rubber seal affixed into the control float. The Nozzle shall have a flat seating land surrounding the orifice so that the damage to the rubber seal is prevented. The valve construction shall be proportioned with regard to material strength characteristics, so that deformation, leaking or damage of any kind does not occur by submission to one and half times the designed working pressure. The valve design shall incorporate an over pressure safety feature that will fail without an explosive effect, such as is normally the case when highly compressed air is released suddenly. The feature shall consist of easily replaceable components such as Gaskets, Seals or the like. Connection to the valve inlet shall be facilitated by a screwed NPT male end.
- B. The Air Release/Vacuum Valve shall be a Vent-O-Mat Model RBX.

2.27 PRESSURE TESTING

- A. When the station plumbing is completed, the pressure piping within the station (including valves, meter, and fittings), connections as make up the entire system shall be hydrostatically tested at a pressure of 150 psi or a pressure equal to the lowest test pressure rating of the equipment within the tested system, whichever is lesser pressure. The test pressure shall be applied for a minimum of 20 minutes, during which time all joints, connections and seams shall be checked for leaking. Any deficiencies found shall be repaired and the system shall be retested.

- B. The results of this testing shall be transmitted in writing to the Engineer prior to shipment of the station and shall note test pressure, time at full pressure and be signed by the Quality Control Manager or test technician.

END OF SECION 13250

SECTION 15041

DISINFECTION OF PIPE AND WATER STORAGE FACILITIES

PART 1 GENERAL

1.01 DESCRIPTION

This section describes requirements for disinfection by chlorination of potable water mains, services, pipe appurtenances and connections.

1.02 REFERENCED STANDARDS

The publications listed below form part of this specification to the extent referenced and are referred to in the text by the basic designation only. Reference shall be made to the latest edition of said standards unless otherwise called for:

AWWA B301	Standard for Liquid Chlorine
AWWA C651	Disinfecting Water Main
AWWA C652	Tank Disinfection

1.03 RELATED WORK SPECIFIED ELSEWHERE

Section 15044	Hydrostatic Testing of Pressure Pipe
Section 15056	Ductile Iron Pipe and Fittings
Section 15057	Copper Tube, Brass and Bronze Pipe Fittings
Section 15064	PVC Pipe (C900)
Section 15070	PVC Pipe (C905)
Section 15076	CML&C Steel Pipe and Specials

1.04 SERVICE APPLICATION

- A. All water mains and appurtenances taken out of service for inspection, repairs, or other activity that might lead to contamination shall be disinfected before they are returned to service.
- B. All new water mains and temporary high lines shall be disinfected prior to connection to the District's existing system.
- C. All components incorporated into a connection to the District's existing system shall be disinfected prior to installation.

1.05 SUBMITTALS

- A. A written disinfection and dechlorination plan signed by a certified chlorinator shall be submitted to the Engineering Manager for review and approval prior to starting disinfection operations.

- B. A Record of Disinfection shall be provided to the Engineering Manager prior to sampling. The Record of Disinfection shall include the time of injection, time length of injection and log of disinfection. Disinfection must be completed by a licensed and certified company.

1.06 DELIVERY, STORAGE AND HANDLING

Chlorination and dechlorination shall be performed by competent individuals knowledgeable and experienced in the operation of the necessary application and safety equipment in accordance with applicable Federal, State and Local laws and regulations. The transport, storage and handling of these materials shall be performed in accordance with Code of Federal Regulations (CFR), and the California Occupational and Health Administration (Cal-OSHA) - California Code of Regulations (CCR), Title 8.

1.07 DISINFECTION AND HYDROSTATIC TESTING

The specified disinfection of the pipelines shall not be performed concurrently with the hydrostatic testing. Disinfection shall only be performed after lines have been flushed and have passed hydrostatic tests per Specification Section 15044.

1.08 CONNECTION TO EXISTING MAINS

Prior to connection to existing mains, disinfection and bacteriological testing shall be performed in accordance with this specification, and hydrostatic testing shall be performed per Specification Section 15044. District authorization for connection to the existing system shall be given only on the basis of acceptable hydrostatic, disinfection and bacteriological test results.

PART 2 MATERIALS

2.01 SODIUM HYPOCHLORITE (LIQUID)

Sodium hypochlorite is available in liquid form in glass or plastic containers, ranging in size from 1 qt. to 5 Gal. The solution contains approximately 10% to 15% available chlorine.

2.02 GRANULAR HYPOCHLORITE

Granular hypochlorite may be used when mixed into a solution containing approximately 10% to 15% available chlorine. When using granular hypochlorite in solution, follow the procedure for sodium hypochlorite solution in this section

PART 3 EXECUTION

3.01 GENERAL

- A. Disinfection of pipelines shall not proceed until all appurtenances and any necessary sample ports have been installed and the Engineering Manager provides authorization.
- B. Every effort shall be made to keep the water main and its appurtenances clean and dry during the installation process.

- C. All piping, valves, fittings, and appurtenances which become contaminated during installation shall be cleaned, rinsed with potable water, and then sprayed or swabbed with a 5% sodium hypochlorite disinfecting solution prior to installation.
- D. Water mains under construction that become flooded by storm water, runoff, or ground water shall be cleaned by draining and flushing with metered potable water until clear water is evident. Upon completion, the entire main shall be disinfected using a method approved by the Engineer.

3.02 METHODS

A. Sodium Hypochlorite Solution (Liquid)

1. Sodium hypochlorite solution shall be used for cleaning and swabbing piping and appurtenances immediately prior to installation and for disinfecting all components of connections to the District's existing system.
2. Sodium hypochlorite solution may be used for the initial disinfection of newly installed water mains. The solution shall be applied at a terminus of the system to be chlorinated using an injector which can adjust the amount of solution being injected into the piping system. The solution shall be injected at the appropriate concentration to achieve the specified concentration range of chlorine throughout the entire piping system. Where pumping equipment is used in conjunction with an injector, an integral backflow prevention device shall be installed and connected to the potable water supply.
3. Pumping equipment, piping, appurtenances and all other equipment in contact with potable water shall be disinfected prior to use. Water trucks shall not be used for disinfection of pipelines.
4. Sodium hypochlorite solution may also be used to increase the total chlorine residual if the concentration from the initial chlorination of the system is found to be low. The solution shall be added to the system in sufficient amounts at appropriate locations to ensure that the disinfecting solution is present at a concentration within the specified range throughout the piping system.

3.03 PROCEDURE FOR DISINFECTING WATER MAINS AND APPURTENANCES

- A. The pipeline shall be filled at a rate not to exceed 300 GPM or a velocity of 1 foot per second (156 GPM in an 8-inch pipe), whichever is less.
- B. Disinfection shall result in an initial total chlorine concentration of 50 ppm to 150 ppm. This concentration shall be evenly distributed throughout the system to be disinfected.
- C. All valves shall be operated with the disinfection solution present in the pipeline. All appurtenances such as air-vacuum relief valves, blowoffs, hydrants, backflow prevention devices, and water service laterals shall be flushed with the treated water for a sufficient length of time to ensure a chlorine concentration within the specified range in all components of each appurtenance. (Note the limitations for discharge of chlorinated water outlined below.)
- D. The Contractor will verify the presence of the disinfection solution throughout the system by sampling and testing for acceptable chlorine concentrations at the various appurtenances

and/or at the test ports provided by the Contractor. Areas of the system found to be below the specified chlorine concentration level shall receive additional flushing as noted above and/or additional disinfection solution as necessary. (Note the limitations for discharge of chlorinated water outlined below.) All testing will be done in the presence of the Engineering Manager.

- E. The chlorinated water shall be retained in the system for a minimum of 24 hours. The Engineering Manager will test the total chlorine residual. The system shall contain a total chlorine residual of not less than 80% of the initial total chlorine residual before the 24-hour soaking period began. If the total chlorine residual has decreased more than 20%, the system shall be soaked for an additional 24-hour period. If the total chlorine residual has not decreased after this additional 24-hour period, the system shall be flushed in accordance with the procedure detailed herein. If the total chlorine residual has decreased, the system shall be flushed in accordance with the procedure detailed herein, and shall be re-disinfected.
- F. Following a successful retention period as determined by the Engineering Manager, the chlorinated water shall be flushed from the system at its extremities and at each appurtenance, using potable water from a source designated by the Engineering Manager. The minimum water velocity during flushing shall be 3 feet per second or as directed by the Engineering Manager. Flushing shall continue until the replacement water in the new system is equal in chlorine residual to the potable source of supply as verified by the Engineering Manager. (Note the limitations for discharge of chlorinated water outlined below.)
- G. The testing firm will perform bacteriological sampling and testing, in accordance with paragraph 3.05 below, and provide a certificate of compliance to the Engineering Manager that the unit tested met the AWWA C651 requirements.

3.04 DISINFECTION OF WATER-STORAGE FACILITIES

Disinfection of water storage facilities shall be done in accordance with AWWA – C652.

3.05 DISCHARGE OF CHLORINATED WATER

- A. Indiscriminate onsite disposal or discharge to sewer systems, storm drains, drainage courses or surface waters of chlorinated water is prohibited.
- B. The environment to which the chlorinated water is to be discharged shall be examined by the Developer, Certified Chlorinator, and the Engineering Manager. Where necessary, federal, state and local regulatory agencies shall be contacted to determine special provisions for the disposal of chlorinated water. Any discharge of chlorinated water to the environment shall require the neutralizing of the chlorine residual by means of a reducing agent in accordance with AWWA C651, San Diego Regional Water Quality Control Board (SDRWQCB), Standardized Best Management Practices for Portable Water Discharges in Region 9 and the requirements of this specification.
- C. A chlorine reducing agent shall be applied to the water prior to exiting the piping system. The Certified Chlorinator shall monitor the chlorine residual during the discharge operations. Total residual chlorine limits in these locations, and for the discharge of chlorinated water from the testing of pipelines to surface waters of the San Diego Region are as follows:

Total Residual Chlorine Effluent Limitations

Instantaneous Maximum - 0.02 ppm

The various methods of dechlorination available can remove residual chlorine to concentrations below standard analytical methods of detection, 0.02 ppm, which will assure compliance with the effluent limit. The Contractor will perform all necessary tests to ensure that the total residual chlorine effluent limitations listed above are met.

3.06 BACTERIOLOGICAL TESTING

- A. RMWD Staff will perform bacteriological sampling and send the sample to the laboratory for testing of all new system installations. The testing methodology employed shall be in accordance with AWA 651. The Certified Laboratory will analyze the samples for the presence of coliform bacteria and heterotrophic-type bacteria (heterotrophic plate count).
- B. The evaluation criteria employed by the District for a passing test sample is as follows:
 - 1. Coliform bacteria: no positive sample
 - 2. Heterotrophic plate count (HPC): 500 colony forming units/ml or less.

3.07 REDISINFECTION

If the initial disinfection fails to produce satisfactory bacteriological test results, the pipeline system shall be re-flushed and re-sampled. If the second set of samples does not produce satisfactory results, the pipeline system shall be re-chlorinated, flushed, and re-sampled. The chlorination, flushing, and sampling procedure shall continue until satisfactory results are obtained. Re-disinfection and retesting shall be at the Contractor's expense.

3.08 DISINFECTING TIE-INS AND CONNECTIONS

Pipes, fittings, valves and all other components incorporated into connections with the District's existing system shall be spray disinfected or swabbed with a liquid chlorine solution in accordance with AWWA C651 and as specified herein. Upon connection to the main, the line shall be flushed as directed by the Engineering Manager. Disinfection by this method is generally limited to assemblies of 20-feet or less in length. Alternate methods such as "pre-disinfection" prior to installation in accordance with AWWA C651 may be required at the discretion of the Engineering Manager.

END OF SECTION 15041

SECTION 15043

SEWER LEAKAGE AND INFILTRATION TESTING

PART 1 GENERAL

1.01 DESCRIPTION

This section describes the requirements and procedures for leakage and infiltration testing of gravity sewer systems.

1.02 REFERENCED STANDARDS

The publications listed below form part of this specification to the extent referenced and are referred to in the text by the basic designation only. Reference shall be made to the latest edition of said standards unless otherwise called for:

UNI-B-6	Recommended Practice for Low-Pressure Air Testing of Installed Sewer Pipe
SSPWC	Standard Specifications for Public Works Construction ("Greenbook")

1.03 RELATED WORK SPECIFIED ELSEWHERE

Section 02223	Trenching, Backfilling and Compacting
Section 03461	Precast Concrete Manholes
Section 15044	Hydrostatic Testing of Pressure Pipe

1.04 REQUIREMENTS PRIOR TO TESTING

Trenching for all dry utilities such as electrical, telephone and cable television shall be completed prior to performing any tests on the sewer pipe.

1.05 TESTING

- A. Leakage Test: Each section of sewer pipe between two successive manholes shall be tested for leakage. The sewer laterals to the property line shall be included in the test.
- B. Infiltration Test: In addition to the leakage test, an infiltration test shall be made where groundwater is encountered, or evidence exists that ground water has encroached to the elevation of the sewer, and as directed by the Engineering Manager.
- C. Closed Circuit Television: A closed circuit television inspection shall be required to be performed, by the Contractor, on the sewer installation.
- D. All tests shall be made in the presence of the Engineering Manager.
- E. Testing may be repeated, as directed by the Engineering Manager, if the subsequent construction operations of the Contractor or others may have damaged or affected the structural integrity of the sewer pipe and/or laterals.
- F. The official District test will not be made until after all other utilities have been installed and trench compaction verified.

- G. All tests must be completed before the street or trench is paved, unless otherwise allowed by the Engineering Manager.
- H. Vacuum testing of manholes shall be performed in accordance with Specification Section 03461.

PART 2 MATERIALS

The Contractor shall furnish all equipment and materials required for testing.

PART 3 EXECUTION

3.01 AIR TEST FOR PVC GRAVITY SEWERS

- A. PVC pipe shall be air pressure tested in accordance with the test procedures outlined in Green Book Section 306-1.4.4, Amendment 306-1.4.4.1, and the Low Pressure Air Test for Sanitary Sewers as published by the National Clay Pipe Institute. The test shall be made only after the line has been properly installed including any necessary test fittings, and backfilled.
- B. Test plugs shall be carefully placed at each end of the section of the line to be tested. When all necessary test equipment is in place, a compressed air supply shall be attached within the line and increased to four (4) pounds per square inch (4 psi). After the air supply is securely turned off or disconnected, there shall be a two (2) minute waiting period to allow stabilization of air within the sewer line before the actual test period begins. Air may be added only to maintain a pressure of 4.0 psig. When the internal pressure decreases to 3.5 psig, timing shall start and the seconds counted until the pressure has decreased to 2.5 psig.
- C. Minimum permissible pressure holding times for sewer main, with or without laterals, are listed in the NCPI Air Test Tables, as published in the latest National Clay Pipe Institutes "Low Pressure Air Test for Sanitary Sewers (Procedures and Tables)." The maximum length of a line that may be tested at one time shall be five hundred (500) feet, or the length between any two (2) adjacent manholes, or where otherwise directed by the Engineering Manager. After completion of the test, the air pressure shall be released slowly through the valve, which is incorporated in the test equipment. Air test plugs shall not be removed until the air pressure is no longer measurable.
- D. All necessary test equipment shall be furnished by the Contractor and the Contractor shall conduct all testing at no cost to the District.

3.02 INFILTRATION TEST

- A. Prior to testing for infiltration, the ends of the sewer pipe section to be tested shall be cleaned using a Wayne Ball, all pipe shall be capped or plugged to prevent the entrance of water, and pumping of groundwater shall be discontinued for at least three (3) days.
- B. Any infiltration discovered before completion and acceptance of the sewer shall be corrected. The sewer shall be examined and the source of infiltration eliminated. Following

repairs or replacement as necessary, including backfill and compaction, the subject line shall be retested to assure no infiltration.

3.03 PRESSURE TESTS FOR SEWER FORCE MAINS

Pressure tests for sewer force mains shall be in accordance with Specification Section 15044 except that the allowable leakage shall be zero (0). All leak points shall be located and stopped. All defective pipes, fittings, valves and other appurtenances discovered shall be removed and replaced with sound material and tests repeated until the leakage is zero (0).

3.04 CLOSED-CIRCUIT TELEVISION INSPECTION

- A. In addition to the leakage and infiltration tests, closed-circuit television inspections will be conducted. The inspection shall be conducted after all utilities have been installed and the backfill compaction certified, but prior to final paving.
- B. Closed-circuit television inspections shall be performed in accordance with the Regional Supplement Amendments to the SSPWC, Section 306.
- C. The video format shall be DVD. A copy shall be provided to the Engineering Manager for review prior to acceptance.
- D. All defects and evidence of reverse slope by ponding of water or dips in pipe alignment revealed by the closed-circuit television inspection shall be repaired to the satisfaction of the Engineering Manager at the Contractors expense.

3.05 VACUUM TESTING OF MANHOLES

Vacuum testing of manholes shall be performed in accordance with Specification Section 03461.

3.06 FINAL ACCEPTANCE

The requirements of this section shall be considered acceptable when each sewer section's air leakage rate is less than the maximum allowed, the television inspection is satisfactory, and the water infiltration rate is zero (0).

END OF SECTION 15043

SECTION 15044

HYDROSTATIC TESTING OF PRESSURE PIPELINES

PART 1 GENERAL

1.01 DESCRIPTION

This section describes the requirements and procedures for pressure and leakage testing of all pressure mains.

1.02 REFERENCE STANDARDS

The publications listed below form part of this specification to the extent referenced and are referred to in the text by the basic designation only. Reference shall be made to the latest edition of said standards unless otherwise called for:

AWWA C600 Installation of Ductile Iron Water Mains

1.03 RELATED WORK SPECIFIED ELSEWHERE

Section 15041	Disinfection of Pipe
Section 15112	Backflow Prevention

1.04 REQUIREMENTS PRIOR TO TESTING

- A. All piping, valves, fire hydrants, services, and related appurtenances shall be installed prior to testing.
- B. The pipe trench shall have trench zone backfill placed and compacted with a minimum of 2.5 feet of material over the pipe.
- C. All concrete anchor blocks shall be allowed to cure a sufficient time to develop a minimum strength of 2,000 psi before testing.
- D. Pressure tests on exposed and aboveground piping shall be conducted only after the entire piping system has been installed and attached to pipe supports, hangers or anchors as shown on the Approved Plans.
- E. Steel pipelines shall not be tested before the mortar lining and coating on all pipe lengths within the line have been in place for a minimum of fourteen (14) days. Cement-mortar lined pipe shall not be filled with water until a minimum of eight hours has elapsed after the last joint has been mortared.

1.05 HYDROSTATIC TESTING AND DISINFECTION OF PIPELINES

Hydrostatic testing of pipelines shall be performed prior to the disinfection operations in accordance with Specification Section 15041.

1.06 CONNECTION TO EXISTING MAINS

Hydrostatic testing shall be performed prior to connections to existing mains. District authorization for connection to the existing system shall be given only on the basis of acceptable hydrostatic, disinfection and bacteriological test results.

PART 2 MATERIALS**2.01 WATER**

- A. Potable water shall be used for hydrostatic testing of potable water mains when such testing is performed separately from disinfection operations.
- B. Potable water shall be supplied by a District approved source. Make-up water for testing shall also be potable water.
- C. Well water shall not be used for hydrostatic testing or any other purposes in new or existing pipelines.

2.02 CONNECTIONS

- A. Testing water shall be supplied through a metered connection equipped with a backflow prevention device in accordance with Specification Section 15112 at the point of connection to the potable water source used.
- B. The Contractor shall provide any temporary piping needed to deliver potable water to the piping that is to be tested.

PART 3 EXECUTION**3.01 GENERAL**

- A. The Contractor shall provide the Engineering Manager with a minimum of five (5) working days notice prior to the requested date and time for hydrostatic tests.
- B. The Contractor shall furnish all labor, materials, tools, and equipment for testing.
- C. Temporary blocking during the tests will be permitted only at temporary plugs, caps or where otherwise directed by the Engineering Manager.
- D. All valves and appurtenances shall be operated during the test period. The test shall be conducted with valves in the open position.
- E. At the onset of testing, all valves, air vacuum assemblies, blowoffs, and services shall be monitored for possible leakage and repairs made, if necessary, before the test proceeds. The appurtenances shall be monitored for the duration of testing.
- F. For pipe with porous lining, such as cement mortar, the pipe shall be filled with water and placed under a slight pressure for a minimum of two (2) working days prior to the actual hydrostatic test.

3.02 FIELD TEST PROCEDURE

- A. Before applying the specified test pressure, care shall be taken to release all air within the pipe and appurtenances to be tested. Air shall be released through services, fire hydrants, air release valves, or other approved locations.
- B. A five (5) hour hydrostatic pressure test shall be performed after the pipe and all appurtenances have been installed and after any trench backfill compaction with heavy-duty compaction equipment has been completed. The hydrostatic test pressure shall be 50 psi above the class rating of the pipe at the lowest point in the section being tested and shall be at least equal to the design class of the pipe at the highest point in the line.
- C. The test pressure shall be applied and continuously maintained by pumping for a period of four (4) hours. During the pumping phase of the test, the test pressure shall be maintained within 5 psig of the specified test pressure at all times.
- D. At the end of the fourth (4th) hour, the pressure shall meet the requirements stated above. Pumping shall then be discontinued for one (1) hour and the drop in pressure shall be recorded. Pumping shall then be resumed to restore the initial test pressure, and the quantity of water pumped into the line shall be accurately measured. This measured quantity shall not exceed that which would result from leakage at the following rates:

1. The allowable leakage for steel (flanged or welded) and ductile iron (flanged) pipe shall be zero.
2. The leakage for polyvinyl chloride (PVC) pipe and for steel or ductile-iron pipes with rubber joints shall be considered as the total amount of water pumped into the pipe system after the fifth (5th) hour of testing. Allowable leakage during the fifth (5th) hour shall be in accordance with AWWA C600-99 and calculated using the following formula:

$$L = \frac{S * D * (P)^{0.5}}{133,200}$$

L = testing allowance (gallons / hour)

S = length of pipe tested (feet)

D = nominal diameter of pipe (inches)

P = average test pressure during test (pounds / sq. inch (gage))

3. If leakage exceeds the allowable loss, the leak points shall be located and repaired as required by the Engineering Manager. All defective pipe, fittings, valves, and other appurtenances discovered shall be removed and replaced with reliable material. Additional disinfection shall be performed as necessary per Specification Section 15041. The hydrostatic test shall be repeated until the leakage does not exceed the rate specified above. All visible leaks shall be similarly repaired.

END OF SECTION 15044

SECTION 15056**DUCTILE-IRON PIPE AND FITTINGS****PART 1 GENERAL****1.01 DESCRIPTION**

This section includes materials and installation of ductile-iron pipe and fittings for potable and recycled water systems. A written request to use Ductile Iron in lieu of CML&C steel must be submitted to the Engineering Manager and approved in writing.

1.02 REFERENCE STANDARDS

The publications listed below form part of this specification to the extent referenced and are referred to in the text by the basic designation only. Reference shall be made to the latest edition of said standards unless otherwise called for:

ANSI B1.1	Unified Inch Screw Threads
ASTM A193	Standard Specification for Alloy-Steel and Stainless Steel Bolting Materials for High-Temperature Service
ASTM A307	Standard Specification for Carbon Steel Bolts and Studs
ASTM C150	Standard Specification for Portland Cement
ASTM A536	Standard Specifications for Ductile Iron Castings
AWWA C104	Cement Mortar Lining for Ductile Pipe and Fittings for Water mains
AWWA C110	Ductile Iron Fittings
AWWA C111	Rubber-Gasket Joints for Ductile Iron Pipe and Fittings
AWWA C115	Flanged Ductile Iron Pipe with Threaded Flanges
AWWA C150	Thickness Design of Ductile Iron Pipe
AWWA C151	Ductile Pipe, Centrifugally Cast
AWWA C153	Ductile Iron Compact Fittings
AWWA C207	Steel Pipe Flanges for Waterworks Service – Sizes 4" through 144"
AWWA C217	Cold-Applied Petroleum Wax Tape Coatings
AWWA C600	Installation of Ductile Iron Water Mains
AWWA C602	Cement-Mortar Lining of Water Pipelines
AWWA C606	Grooved and Shouldered Type Joints

1.03 RELATED WORK SPECIFIED ELSEWHERE

RMWD	Standard Drawings
Section 02223	Trenching, Backfilling and Compacting
Section 03300	Cast-in-Place Concrete
Section 09900	Painting and Coating
Section 15041	Disinfection of Pipe
Section 15044	Hydrostatic Testing of Pressure Pipe

1.04 SERVICE APPLICATION

Ductile-iron pipe shall be used only in specific areas, locations, and uses allowed by the Engineering Manager.

1.05 QUALITY ASSURANCE

- A. The manufacturer of each shipment of pipe shall be required to supply a statement certifying that each lot or load of pipe and fittings has been subjected to and met the tests specified for ductile-iron pipe and fittings per AWWA C110, C111, C115, C150, C151, and C153, as applicable.
- B. All pipe shall have a home mark on the spigot end to indicate proper penetration when the joint is made.
- C. Ductile-iron pipe shall bear indelible identification markings as required by AWWA C151.

1.06 SUBMITTALS

The following items shall be submitted and reviewed by the Engineering Manager prior to shipping of ductile-iron pipe and fittings:

- A. An affidavit of compliance with AWWA C104, C110, C111 , C115, C150, C151, C153, and the requirements of this specification.
- B. Typical joint details.
- C. Typical details and description of lining and coating.
- D. Calculations supporting selected wall thickness.
- E. Calculations demonstrating that each proposed restrained joint arrangement can resist the applied forces.
- F. Cathodic protection materials.

1.07 DELIVERY, STORAGE, AND HANDLING

Delivery, storage, and handling of ductile-iron pipe and fittings shall follow the recommendations of AWWA C600 and as specified herein:

- A. Handling of pipe shall be performed with lifts, cranes, or other suitable equipment and devices. Slings, hooks, or pipe tongs shall be padded and used in such a manner as to prevent damage to the pipe, linings, and coatings. The pipes shall not be dropped or dragged.
- B. During transport, the pipe shall be supported and secured against movement using padded devices in such a manner to prevent damage.
- C. Stored pipe shall be protected from damage and kept free from dirt and foreign materials by closing the ends of the pipe. Other pipeline materials shall be protected by appropriate packaging or wrapping. Gaskets shall be stored in a cool location out of direct sunlight. Bolts, nuts, and washers shall be handled and stored in a dry location in a manner that will ensure proper use with respect to types and sizes.
- D. Pipe laid out for installation shall be placed on earth berms or timber cradles adjacent to the trench in the numerical order of installation.
- E. Maintain plastic end caps on all pipe and fittings in good condition until the pipe is ready to be installed in the trench. Periodically open the plastic end caps and spray clean potable water inside the pipe for moisture control.
- F. Under no circumstances shall ropes or other devices be attached through the fitting's interior for handling.

PART 2 MATERIALS**2.01 DUCTILE-IRON**

- A. General:
 - 1. Ductile-iron pipe and fittings shall be manufactured per AWWA C110, C111, C115, C150, C151, and C153. Gray-iron and cast-iron fittings or flanges shall not be used.
 - 2. Ductile-iron fittings manufactured per AWWA C153 shall be installed on mains 12-inch and smaller only.
 - 3. Joints for ductile-iron pipe and fittings shall be mechanical, flanged, or push-on in accordance with AWWA C110, C111, and C153.
 - 4. Except as amended herein, or otherwise shown on the Approved Plans, joints for ductile-iron pipe and ductile-iron fittings shall have a pressure rating equal to or greater than the adjacent piping.
 - 5. Joints in buried piping may be of the push-on, flanged or mechanical- joint type per AWWA C111 except where particularly specified on the Approved Drawings.

6. Joints that are aboveground, within structures, or submerged shall be flanged unless otherwise shown on the Approved Plans.

- B. Unless otherwise specified, ductile-iron flanges shall be in accordance with AWWA C115, rated at a working pressure of 250 psi. Where required in order to connect to the flanges of 250 psi butterfly valves, or as otherwise shown on the approved plans, ductile-iron flanges shall be compatible with AWWA C207, Class "E".

Maximum working pressure of flanges shall as specified in AWWA or ASME/ANSI. Flanges shall be integrally cast per AWWA C110 or shop-threaded per AWWA C115. Flanges shall be solid. Hollow-back flanges are not permitted. Gray-iron or cast-iron flanges are not permitted. Threading of flanges in the field is not permitted.

Where threaded flanges are used, the pipe or spool piece to which they are connected will be hydrostatically tested in the presence of the Engineering Manager prior to installation. The pipe section or spool piece shall be hydrostatically tested for 15 minutes at the pressure rating of the flanges. No leaks shall be permitted.

- C. Plain ends shall conform to the requirement of AWWA C151 and to the dimensions included within AWWA C110 to accept a mechanical joint, push-on joint, flanged coupling adaptor, flexible coupling, or grooved coupling.
- D. The exterior surfaces of all pipe and fittings shall be factory coated with a minimum one (1) mil thick petroleum asphaltic material per AWWA C110 and C151.
- E. All pipe and fittings shall be cement-mortar lined in accordance with AWWA C104, using the double thickness requirements indicated in said standard, Type II or Type V Portland cement per ASTM C 150 shall be used.

2.02 GASKETS

- A. Mechanical joint rubber gasket configuration and materials shall comply with AWWA C111, and according to the applicable joint type and pressure rating of the piping system.
- B. Flange gaskets shall be 1/8-inch thick acrylic or aramid fibers bound with nitrile for all sizes of pipe. Gaskets shall be full-face type with pre-punched holes. Ring gaskets extending to the inner edge of the bolt circumference may be used only upon approval of the Engineering Manager.
- C. Insulating Sections. Where a metallic nonferrous pipe or appurtenance is connected to ferrous pipe or appurtenance, an insulating flange gasket kit shall be provided. Each insulating gasket shall have a pressure rating equal to or exceeding the connecting pipes.
- D. Push-on joint rubber gaskets shall be per AWWA C111.
- E. If organic solvents or petroleum products are encountered during the course of the work, alternate gasket materials or joint treatment may be required by the Engineering Manager.

2.03 MECHANICALLY RESTRAINED JOINTS

Mechanically restrained joints shall have boltless positive lock ring type joints as manufactured by U.S. Pipe TR Flex, American Pipe Lok Ring, Megalug or approved equal. The design shall permit disassembling of the joint for repair and maintenance. External type harnesses and internal type restraints will not be allowed.

2.04 BOLTS AND NUTS FOR FLANGES

Bolts and nuts shall be as indicated below and shall be selected from the Approved Materials List.

- A. Stainless steel bolts and nuts shall be used for the installation of pipelines 24-inch diameter and larger and for submerged flanges. Bolts and nuts shall be Type 316 stainless steel conforming to ASTM A193, Grade B8M for bolts, and Grade 8M for nuts.
- B. All bolt heads and nuts shall be hexagonal, except where special shapes are required. Bolts shall be of such length that not less than 1/4-inch or more than 1/2-inch shall project past the nut in tightened position.

2.05 PAINTING AND COATING

- A. Buried ductile-iron pipe shall receive an asphaltic coating in accordance with AWWA C115.
- B. Materials for coating of pipe and fittings located above ground and in structures shall be in accordance Specification Section 09900.
- C. Materials for coating buried mechanical joint and hardware shall be in accordance Specification Section 13110.

2.06 IMPORTED GRANULAR MATERIAL FOR PIPE AND TRENCH ZONES

Imported granular material for use in pipe and trench zones shall be in accordance with Specification Section 02223.

2.07 CONCRETE

Concrete for thrust and anchor blocks shall be in accordance with Specification Section 03300.

2.08 POLYETHYLENE ENCASEMENT

Polyethylene encasement shall consist of a tube of at least 8 mils thickness and be selected from the Approved Materials List. Plastic adhesive tape for polyethylene encasement shall be 2-inches wide and be selected from the Approved Materials List.

2.09 WARNING/IDENTIFICATION TAPE

Use marking tape consisting of one layer of aluminum foil laminated between two (2) colored layers of inert plastic film. The lamination bond shall be strong enough that the layers can not be separated by hand. Tape shall be a minimum of 5 mils thick and 6 inches wide. Elongation shall be a minimum of 600%. Tape shall bear a continuous, printed, message every 16 to 36-inches warning of the installation buried below. Tape shall be selected from the Approved Materials List.

PART 3 EXECUTION**3.01 GENERAL**

At all times when the work of installing pipe is not in progress, including worker break times, ends of the pipe shall be closed with a vermin-proof and child-proof cap or plug. Do not permit trench water to enter the pipe. Do not place tools, clothing, or other materials in the pipe. The Contractor shall maintain the interior of the pipe in a sanitary condition free from foreign materials.

3.02 TRENCHING, BACKFILLING AND COMPACTING

Trenching, backfilling and compacting shall be performed in accordance with Specification Section 02223.

3.03 DEWATERING

- A. The Contractor shall provide and maintain at all times during construction ample means and devices to promptly remove and dispose of all water from any source entering trench excavations or other parts of the work in accordance with Specification Section 02223. Any damage caused by flooding of the trench shall be the Contractor's responsibility.
- B. Dewatering shall be performed by methods that will maintain a dry excavation, preservation of the final lines and grades and protection of all utilities. If flooding of the trench does occur, the Contractor shall immediately dewater and restore the trench. Damaged or altered pipeline appurtenances or trench materials shall be repaired or replaced as directed by the Engineering Manager.

3.04 PIPE INSTALLATION

- A. When the work requires and the size of the pipe allows entry of personnel into the pipe, the Contractor shall comply with all Federal and State regulations for confined space entry. Work inside pipelines shall not be undertaken until all the tests and safety provisions of the Code of Federal Regulations 1910.146, and the General Industry Safety Orders of the California Code of Regulations, Title 8, Section 5159 for confined space entry have been performed and the area is verified as safe to enter .
- B. The Contractor shall furnish and install all pipe, specials, fittings, closure pieces, valves, supports, bolts, nuts, gaskets, jointing materials, and all other appurtenances as shown on the Approved Plans and as required to provide a complete and workable installation. Install pipe in the trench as follows:
 - 1. Inspect each pipe and fitting before lowering the pipe or fitting into the trench. Inspect the interior and exterior protective coatings. Patch damaged areas in the field with material recommended by the protective coating manufacturer. Thoroughly clean the ends of the pipe. Remove foreign matter and dirt from inside of the pipe and keep pipe clean during and after installation.
 - 2. Install pipe according to the manufacturer's approved order of installation. Install pipes uphill if the grade exceeds 10%. Lower the pipe onto the bedding at the proper lines and grades.

3. The manufacturer's printed installation guide outlining the radius of curvature that can be negotiated with pipe sections of various lengths shall be followed, except they shall not exceed the deflections allowed in AWWA C600 according to joint type. Combined deflections at rubber gasket or flexible coupling joints shall not exceed that recommended by the manufacturer.
4. The pipe shall have firm bearing along its full length, and bell holes shall be provided at each joint to permit visual inspection of the joint and prevent the pipe from being supported by the bell end or coupling.

C. Pipe Assembly

1. **Push-On Type:** Assemble the pipe joint using a lubricant selected from the Approved Materials List. Insert the spigot end into the bell or coupling to the proper insertion mark. Check that the elastomeric ring has not left the groove during assembly by passing a feeler gauge around the completed joint. Drive spigot ends of the pipe into bell ends in accordance with the manufacturer's recommendations. Stabbing shall not be permitted.
2. **Mechanical Joint Type:** Assembly of mechanical joint fittings shall be in accordance with the manufacturer's recommendations regarding installation.

D. During installation operations, do not place tools, clothing, or other materials in the pipe.

E. When pipe installation is not in progress, including worker break times, ends of the pipe shall be closed with a vermin-proof and child-proof cap or plug. Do not permit trench water, animals, or foreign material to enter the pipe.

3.05 POLYETHYLENE ENCASEMENT

Polyethylene encasement shall be used for the buried installation of ductile iron and fittings and shall be installed in accordance with AWWA C105, Method A.

3.06 FLANGED PIPE AND FITTINGS

Flanged connections shall be installed where indicated on the Approved Drawings.

- A.** Bolt holes shall straddle the horizontal and vertical centerlines.
- B.** The bolts, nuts and flange faces shall be thoroughly cleaned by wire brush prior to assembly.
- C.** Bolts and nuts shall be lubricated with a District-approved anti-seize compound.
- D.** Nuts shall be tightened in an alternating "star" pattern to the manufacturer's recommended torque.
- E.** Coat the exterior of exposed flanges, bolts and nuts located aboveground or within vaults in accordance with Specification Section 09900.

3.07 MECHANICAL JOINT CONNECTIONS

- A. Install mechanical joint connections per AWWA C600 and the manufacturer's recommendations.
- B. Prior to installation of the mechanical joint, clean the socket and plain end of the pipe. Lubricate both the gasket and plain end of the pipe with an approved lubricant per AWWA C111 immediately prior to slipping the gasket onto the plain end of the pipe.
- C. Tighten the bolts to the normal range of bolt torque per the manufacturer's recommendations and AWWA C600, Table 3.

3.08 COUPLINGS FOR DUCTILE-IRON PIPE

Mechanical type flexible joints shall be installed where shown on the Approved Drawings. Grooved couplings shall be used in vaults and above ground. Flexible couplings may be used, where indicated on the drawings, below ground, but may also be used above ground with restrained joints. Flanged coupling adapters shall be used for buried pipelines, where allowed by the Engineering Manager.

- A. Grooved joint couplings shall be installed per AWWA C606.
- B. Flanged coupling adapters, where allowed by the Engineering Manager, shall be installed per the manufacturer's recommendations.
- C. Flexible couplings shall be installed per the manufacturer's recommendations.
- D. All couplings for ductile-iron pipe shall be shop-coated in accordance with Specification Section 09900.

3.09 CONCRETE

Concrete thrust and anchor blocks shall be installed in accordance with Specification Section 03300 and the Standards Drawings. Prior to filling the pipeline with water, refer to Specification Section 03300 for the minimum concrete curing time required.

3.10 WARNING/IDENTIFICATION TAPE

After the pipe zone and the first 12-inches in the trench zone have been backfilled and compacted, place the marking tape on the compacted backfill and center over the pipe. Run tape continuously along the trench and tie ends of tape together. Wrap marking tape around valve box extension pipes and continue along pipe.

3.11 DISINFECTION AND BACTERIOLOGICAL TESTING

Disinfection, bacteriological testing, and flushing shall be performed in accordance with Specification Section 15041.

3.12 HYDROSTATIC TESTING

Field hydrostatic testing shall be performed in accordance with Specification Section 15044.

END OF SECTION 15056

SECTION 15057

COPPER TUBING, BRASS AND BRONZE PIPE FITTINGS

PART 1 GENERAL

1.01 DESCRIPTION

This section includes materials and installation of copper tubing, brass and bronze pipe fittings and appurtenances. Pipe fittings must comply with California State Law requirements for “lead free” plumbing (Statue: CH&SC 116875).

1.02 REFERENCE STANDARDS

The publications listed below form part of this specification to the extent referenced and are referred to in the text by the basic designation only. Reference shall be made to the latest edition of said standards unless otherwise called for:

ANSI B1. 1	Unified Inch Screw Threads
ANSI B1.2	Gauges and Gauging for Unified Inch Screw Threads
ANSI B1.20.1	Pipe Threads, General Purpose (Inch)
ANSI B16.24	Cast Copper Alloy Pipe Flanges and Flanged Fittings
ASTM A307	Carbon Steel Bolts and Studs
ASTM B43	Seamless Red Brass Pipe, Standard Sizes
ASTM B62	Composition Bronze or Ounce Metal Castings
ASTM B88	Seamless Copper Water Tube
ASTM B88M	Seamless Copper Water Tube [Metric
AWWA C800	Underground Service Line Valves and Fittings

1.03 RELATED WORK SPECIFIED ELSEWHERE

RMWD	Standard Drawings
Section 02223	Trenching, Backfilling and Compacting
Section 05550	Misc. Metals
Section 15041	Disinfection of Pipe
Section 15044	Hydrostatic Testing of Pressure Pipe

PART 2 MATERIALS

2.01 COPPER TUBING

Copper tubing shall conform to the requirements of ASTM B 88 Type K. Copper tubing up to 1-inch diameter shall be soft. Copper tubing 2-inches in diameter may be soft when pressures are 150psi and less. Components shall be selected from the Approved Materials List in accordance with the Standard Drawings.

2.02 BRASS PIPE, NIPPLES, AND FITTINGS

Threaded nipples, brass pipe and fittings shall conform to ASTM B 43, regular wall thickness. Threads shall conform to ANSI B1.20. 1. Fittings shall be compression type. Brass pipe shall not contain lead material.

2.03 BRONZE APPURTENANCES

- A. Corporation stops, curb stops, meter and angle meter stops, meter flange adapters, and bronze-bodied service saddles shall be selected from the Approved Materials List in accordance with the Standard Drawings.
- B. Fittings shall be threaded type.
- C. All items specified herein shall be manufactured of bronze conforming to ASTM B 62.
- D. Service saddles shall be the double strap type. Service saddles shall be used on all service and appurtenance connections on PVC piping. For piping materials other than PVC, service and appurtenance connections shall be performed in accordance with the Approved Drawings.

2.04 BOLTS AND NUTS FOR FLANGES

Bolts and nuts shall be in accordance with the Approved Materials List.

2.05 WARNING/IDENTIFICATION TAPE

Use marking tape consisting of one (1) layer of aluminum foil laminated between two (2) colored layers of inert plastic film. The lamination bond shall be strong enough that the layers can not be separated by hand. Tape shall be a minimum of 5 mils thick and 6 inches wide. Elongation shall be a minimum of 600%. Tape shall bear a continuous, printed, message every 16 to 36-inches warning of the installation buried below. Tape shall be Terra Tape, Linetec, or District approved equal.

PART 3 EXECUTION**3.01 COPPER TUBING AND FITTINGS**

- A. Trenching, bedding, backfilling and compacting shall be performed in accordance with Specification Section 02223 and the Standard Drawings. Provide a minimum cover of 30-inch below finished street grade.
- B. Cut tubing true and square and remove burrs.
- C. Bends in soft copper tubing shall be long sweep. Shape bends with shaping tools. Form bends without flattening, buckling, or thinning the tubing wall at any point.
- D. Assemble copper tubing and fittings per the manufacturer's recommendation in accordance with the Standard Drawings.
- E. For water services 2-inches and less, Corp Stops shall be insulated type and selected from the Approved Material List.

- F. Service Stops shall be installed such that, while standing on the District side of the meter box, the locking wing is located on the left side of the service lateral with the lock holes facing up in order to facilitate right hand operation of the valve while standing on the District side.

3.02 SERVICE SADDLES

- A. Service saddles shall be located a minimum of 24-inch from any pipe joint or fittings.
- B. Service saddles for connections shall be located a minimum of 24-inch from other saddles. Additionally, multiple service saddles for connections that are installed on the same side of a single pipe length shall be alternately staggered between 35° and 55° to prevent a weak plane in the pipe.
- C. The surface of the pipe shall be clean and all loose material shall be removed to provide a hard, clean surface.
- D. The service saddle shall be tightened in accordance with the manufacturer's recommendations to ensure a tight seal, using care to prevent damage or distortion of the service saddle or corporation stop due to over-tightening.
- E. The tap into the pipe shall be made in accordance with the pipe manufacturer's recommendation. Tapping tools and shell cutters with internal teeth or double slots that will retain the coupon shall be used.
- F. Service Saddles shall be the Double-Strap type and selected from the Approved Materials List.

3.03 WARNING/IDENTIFICATION TAPE

After the pipe zone and the first 12-inches in the trench zone have been backfilled and compacted, place the marking tape on the compacted backfill and center over the pipe. Run tape continuously along the trench and tie ends of tape together. Wrap marking tape around valve box extension pipes and continue along pipe.

3.04 DISINFECTION AND BACTERIOLOGICAL TESTING

Disinfection, bacteriological testing, and flushing shall be performed in accordance with Specification Section 15041.

3.05 HYDROSTATIC TESTING

Field hydrostatic testing shall be performed in accordance with Specification Section 15044.

END OF SECTION 15057

SECTION 15062

**POLYVINYL CHLORIDE (PVC)
GRAVITY SEWER PIPE AND FITTINGS**

PART 1 GENERAL

1.01 DESCRIPTION

This section designates the requirements for the manufacture and installation of polyvinyl chloride, abbreviated PVC, gravity sewer pipe to be furnished and installed by the Contractor, at the location and to the lines and grades shown on the Plans as herein specified. Included in this section are requirements for tie-ins and sewer bypassing.

1.02 REFERENCE STANDARDS

The publications listed below form part of this specification to the extent referenced and are referred to in the text by the basic designation only. Reference shall be made to the latest edition of said standards unless otherwise called for:

ASTM D1784	Rigid PVC Compounds
ASTM D2321	Underground Installation of Flexible Thermoplastic Sewer Pipe
ASTM D2412	Pipe Stiffness Test
ASTM D2564	Solvent Cements for PVC Pipe Fittings
ASTM D3034	PVC Sewer Pipe and Fittings (4" to 15")
ASTM D3212	Joints for Drain and Sewer Plastic Pipe Using Elastomeric Seals
ASTM F477	Elastomeric Gaskets for Joining Plastic Pipe
ASTM F679	PVC Large Diameter Gravity Sewer Pipe and Fittings (18" to 27")
UNI-B-5	Uni Bell Recommended Practice for the Installation of PVC Sewer Pipe

1.03 RELATED WORK SPECIFIED ELSEWHERE

RMWD	Standard Drawings
Section 02223	Trenching, Backfilling and Compacting
Section 03461	Precast Concrete Manholes
Section 15043	Testing of Gravity Sewer

1.04 SUBMITTALS

The Contractor shall furnish submittals in accordance with Section 1 - General Conditions. Submittals are required for the following:

- A. Submit Shop Drawings, material lists, manufacturer's literature and catalog cuts and other information.

- B. An affidavit from the pipe manufacturer including compliance with requirements of the Plans and Specifications shall be delivered with the pipe.
- C. Bypass Plan (if applicable).

PART 2 MATERIALS

2.01 PVC PIPE

- A. PVC gravity sewer pipe shall be made of PVC plastic having a cell classification of 12454-B, 13364-A, or 13364-B as defined in ASTM D1784. PVC gravity sewer pipe, fittings, coupling and joints, 4-inch through 15-inch, shall be manufactured in conformance with the requirements of ASTM D3034, SDR 35 and shall have gasketed joints. All pipe shall be of solid wall construction with smooth interior and exterior surfaces.
- B. Any fittings shall also be made of PVC plastic and have a cell classification of 12454-B, 12454-C, or 13343-C as defined in ASTM D1784. PVC gravity sewer pipe, fittings, coupling and joints, 18-inch through 21-inch, shall be manufactured in conformance with the requirements of ASTM F679 with T-1 wall thickness and shall have gasketed joints. All pipe shall be of solid wall construction with smooth interior and exterior surfaces.
- C. The minimum pipe stiffness for both small diameter and large diameter PVC gravity sewer pipe shall be 46 psi according to ASTM D2412.

2.02 JOINING SYSTEM

- A. The pipe shall be jointed with an integral bell gasketed joint that meets the requirements of ASTM D3212. The gasket shall be manufactured from a synthetic elastomer and factory installed in the belled end of the pipe. Gasket shall conform to ASTM F477.
- B. All pipe shall have a homemark on the spigot end to indicate proper penetration when the joint is made. The socket and spigot configurations for fittings and couplings shall be compatible to those used for the pipe.

2.03 CERTIFICATION

Pipe, fittings, and couplings shall meet the requirements of the section titled "Requirements" of ASTM D3034 SDR 35 (4-inch through 15-inch) and ASTM F679 (18-inch through 27-inch). During production of the pipe, the manufacturer shall perform the specified tests for each pipe marking. A certification by the manufacturer indicating compliance with specification requirements shall be delivered with the pipe. The certification shall include the test result data. Pipe which is not installed within 120 days of latest test shall not be used without prior approval of the Engineering Manager.

2.04 WARNING/IDENTIFICATION TAPE

Use marking tape consisting of one layer of aluminum foil laminated between two colored layers of inert plastic film. The lamination bond shall be strong enough that the layers can not be separated by hand. Tape shall be a minimum of 5 mils thick and 6-inches wide. Elongation shall be a minimum of 600%. Tape shall bear a continuous, printed, message every 16 to 36-inches warning of the installation buried below. Tape shall be selected from the Approved Materials List.

PART 3 EXECUTION

3.01 PIPE LENGTHS

Standard laying lengths shall be 20-feet and 12.5-feet with the manufacturer's option to supply up to 15% random lengths. Combined horizontal and vertical deflections at PVC gravity sewer pipe shall not exceed that recommended by the manufacturer (the maximum total deflection allowed shall be three (3) degrees). Any deflection of the pipe shall be accomplished by bending the pipe along its entire length in the trench and not by deflection at the joints.

3.02 MARKING

All pipe, fittings, and couplings shall be clearly marked at an interval not to exceed 5-feet as follows:

- Nominal Pipe Diameter
- PVC cell classification
- Company, plant, shift, ASTM, SDR, and date designation
- Service designation or legend

For fittings and couplings, the SDR designation is not required.

3.03 EARTHWORK

- A. Excavation and backfill, including the pipe bedding, shall conform to the provisions of Specification Section 02223, Trenching, Backfilling and Compacting, except as herein modified.
- B. Crushed Rock and Gravel: Crushed rock shall be the product of crushing rock or gravel. Fifty percent of the particles retained on a 3/8-inch sieve shall have their entire surface area composed of faces resulting from fracture due to mechanical crushing. Not over five (5) percent shall be particles that show no faces resulting from crushing. Less than ten (10) percent of the particles that pass 3/8-inch sieve and are retained on the No. 4 sieve shall be water worn particles. Gravel shall not be added for crushed rock.
 - 1. Gravel shall be defined as particles that show no evidence of mechanical crushing, are fully waterworn, and are rounded. For pipe bedding, where gravel is specified, crushed rock may be substituted or added.
 - 2. Where crushed rock or gravel is specified in the bedding details on the Plans or in the Specifications, the material shall have the following gradations:

Sieve Size	1/2-Inch Max Crushed Rock % Passing
1"	---
3/4"	100
1/2"	90 - 100
3/8"	20 - 60
No. 4	0 - 15
No. 8	0 - 5

3. Unless otherwise specified, 1/2-inch maximum crushed rock shall be used for pipes with inside diameter of 48-inches and less.
- C. Pipe Bedding: Crushed rock shall be used for pipe bedding and shall be compacted to obtain a relative density of 90% unless otherwise specified. The thickness of the pipe bedding shall be a minimum of 6-inches. The pipe bedding shall be placed over the full width of the trench.
- D. Backfill Within Pipe Zone: Crushed rock shall be placed and compacted within the pipe zone from the bottom of the pipe to 12-inches above the top of the pipe outside diameter. The crushed rock shall be compacted to obtain a relative density of 90% unless otherwise specified.

3.04 GENERAL INSTALLATIONS PROCEDURES AND WORKMANSHIP

- A. PVC pressure pipe and fittings shall be installed per ASTM D2321, Uni Bell pamphlet Uni-B-5, and the manufacturer's recommendations.
- B. Proper care shall be used to prevent damage in handling, moving, and placing the pipe. The Contractor shall unload the pipe by mechanical means such as a crane or backhoe, or by rope and skids, as recommended by the manufacturer. In using skids, pipes must be prevented from striking other pipe. Dropping pipe from truck will not be permitted.
- C. All pipe shall be laid without break, upgrade from structure to structure, with the bell ends of the pipe upgrade. Pipe shall be laid to the line and grade given so as to form a close concentric joint with the adjoining pipe and prevent sudden offsets of the flow line. The interior of the pipe shall be cleaned of all dirt and superfluous materials of all description immediately prior to installing the pipe. The Contractor shall wipe the mating surfaces of the pipe to be joined clean of all dirt and foreign matter and apply an approved lubricant. The spigot end shall be inserted to the proper depth of the socket as indicated by the home mark.
- D. Laying tolerances for the installed pipe shall not vary greater than 0.3-foot horizontally, or greater than 0.1-foot vertically from the alignment and elevations shown on the Approved Drawings.

3.05 BRANCHES

- A. PVC wyes, and other types of branches shall be furnished and installed along with PVC pipe as is called for on the Plans. The longitudinal barrel of branch fittings, to be placed in line and grade with PVC sewer mains, shall be of the same diameter, quality, and type as specified herein for sewer installations, and shall conform to the applicable provisions set forth for PVC gravity sewer pipe. Unless otherwise specified, the branch of wye fittings shall be inclined upward at an angle not greater than 45 degrees from a horizontal line. No wye shall be placed closer than 5-feet in the downstream side to the centerline of any structure. Also no two wyes or tees shall be laid back to back. There shall be a minimum of 3-feet between each branch fitting.
- B. The Contractor shall place a support of grade crushed rock or gravel under every wye branch when installed.

3.06 SADDLE CONNECTIONS

- A. All saddle connections into existing sewer lines shall be made with a wye saddle. The sewer to be saddled shall be scored to the approximate shape of wye or tee and shall be cut by mechanical hole cutters or by keyhole or by sabre saw. The tap holes shall be cleanly machined and may be further worked by hand to provide a true and neat opening for the wye or tee saddle. The Contractor shall replace or repair any pipe damaged during the operation.
- B. Saddles shall be mounted on the pipe with solvent cement in conformance with the requirements of ASTM D2564 or by gaskets with all stainless steel straps. If a solvent welded saddle is used, the saddle shall be secured to the main with stainless steel straps or with saddle clamps. After the connection has set sufficiently long for the solvent cement to cure, the Contractor shall encase the entire fitting and main line with Class A Portland cement concrete.
- C. The Contractor shall carry out the saddling operation only in the most workmanlike manner and he shall keep all chips, dirt, solvent cement, mortar and concrete out of the sewer being saddled. The Contractor shall, if directed to do so by the Engineering Manager, flush, clean and ball the reach of sewer main saddle.
- D. In lieu of a saddle connection, a wye connection may be made by cutting the sewer and installing a wye. All applicable provisions of this Specification will be adhered to in making a cut-in wye connection.

3.07 MANHOLES

Connection of PVC sewer pipe to the manhole shall be water tight. The connection shall be made with a gasket plastic manhole coupling in accordance with Specification Section 03461 and the Standard Drawings.

3.08 PREVENTING FOREIGN MATTER FROM ENTERING THE PIPE

At all times when pipe laying is not in progress, the open end of the pipe shall be closed with a tight-fitting cap or plug to prevent the entrance of foreign matter into the pipe. These provisions shall apply during the noon hour as well as overnight. Under no circumstances shall the pipeline be used as a drain for removing water which has infiltrated into the trench. The Contractor shall maintain the inside of the pipe free from foreign materials and in a clean and sanitary condition until its acceptance by the Owner.

3.09 CLEANING

Before testing, each pipe shall be thoroughly cleaned from manhole to manhole with a sewer scrubbing ball. All debris and trash shall be removed from each manhole. Plywood will be placed on the shelf after cleaning has taken place. The Contractor shall remove plywood when final lift of AC has been applied.

3.10 TEST FOR LEAKAGE AND INFILTRATION

The pipe, and other appurtenances shall be tested for leakage and infiltration in accordance with Specification Section 15043, Testing of Gravity Sewer.

3.11 MANDREL TEST

- A. Following the completion of the required testing, the placement and densification of backfill, and the installation of all utilities, and prior to the placing of the permanent paving, all PVC sewer pipe shall be cleaned and then mandrelled, to measure for obstructions (deflections, joint offsets, and lateral pipe intrusions) in accordance with the requirements of the Standard Specifications for Public Works Construction (latest edition) Section 306-1.2.12. A rigid mandrel, with a circular cross section having a diameter of at least 95% of the specified inside diameter, shall be pulled through the pipe by hand. The minimum length of the circular portion of the mandrel shall be equal to the nominal diameter of the pipe.
- B. Obstructions encountered by the mandrel shall be corrected by the Contractor. All material, equipment, and labor to perform the test shall be provided by the Contractor at no cost to the District.

3.12 SEWER FLOW DIVERSION REQUIREMENTS

- A. Contractor must submit a sewer flow diversion plan to be reviewed by the Engineering Manager when sewer bypassing is required. Allow at least 30 days for review and approval before commencing work. The bypass plan must include at a minimum the following information:
1. Bypassing sequence
 2. Submittal of highline, bypass pumps, and other appurtenances. Specifications of pumping equipment, type, size, capacity and amount of pumps required to handle the peak wet weather flow and include a 100 percent backup in the flow diversion system.
 3. Monitoring plan, including frequency for continuously monitoring flow levels downstream and upstream of the flow diversion to detect any failure. Continuously monitor fuel and ensure that fuel level does not drop below a two hours usage.
 4. Sewage spill and response plan
 5. Maintenance procedures, schedule and monitoring log. The operation procedure should include the cleaning out of the primary pump impellers of any debris as needed.
 6. Drawings showing the location of the bypass pumping equipment for each line segment of the bypass, valves, and piping.
 7. Equipment onsite, including back up plugs, air compressors and repair couplings for highline.
- B. If diversion requires pumping, each pump, including backup pumps must be a complete unit with its own suction and discharge piping. The backup flow diversion system must be fully installed, operation and ready for use. Hydraulically test the diversion system with clean water before wastewater flow diversion. The Engineering Manager must be present during all testing.
- C. At the discretion of the Engineering Manager, a temporary wastewater storage tank or stand-by sewage pumper truck may be required on site during sewage pump switchovers.

- D. The contractor is fully responsible for sewage handling and preventing a sewage spill, containing a sewage spill, recovery and legal disposal of spilled sewage, fines, penalties, claims and liability arising from negligently causing a sewage spill, and violation of law, ordinance, code, order or regulation because of the spill. If a spill occurs, act immediately to control the sewage spill. Take appropriate steps to contain it according to the sewage spill response plan and flow diversion plan. Immediately notify the Engineering Manager and report the situation.

- E. The Engineering Manager may institute further corrective actions to fully comply with existing laws, ordinances, codes, orders or other pertinent regulations. The contractor is responsible for costs incurred for the corrective action including mitigation measures or habitat restoration and obtaining after the fact permits if necessary in environmentally sensitive areas.

- F. Contractor must have the bypassing equipment available and on-site during all construction activities including grading.

- G. Within 3 business days from a spill occurrence, submit a written report to the Engineering Manager describing the following information:
 - 1. Location of spill
 - 2. Estimated volume
 - 3. Date and time of event
 - 4. Duration
 - 5. The cause
 - 6. Type or remedial and or clean up measures taken
 - 7. Date and time of implementation
 - 8. Corrective and or preventive actions taken to avoid further spills
 - 9. Equipment used in spill response
 - 10. Environmentally sensitive habitat
 - 11. Results of necessary monitoring
 - 12. List of parties notified

- H. The sewer spill prevention and response plan must follow the "Zero Spill" policy and must include the following:
 - 1. Identify nearby environmentally sensitive area such as waterway, channel, catch basin and entrance to existing underground storm drain.
 - 2. Make arrangements for an emergency response unit, stationed at or near the job site, comprised of emergency response equipment and trained personal to be immediately dispatched in the event of a sewage spill. Contact numbers shall be included in the plan.
 - 3. Emergency notification procedure that includes emergency response team with telephone numbers and arrangements for backup personal and equipment.

END OF SECTION 15062

SECTION 15064

**POLYVINYL CHLORIDE (PVC) PRESSURE PIPE
(AWWA C900)**

PART 1 GENERAL

1.01 DESCRIPTION

This section includes materials, installation, and testing of polyvinyl chloride (PVC) pressure pipe conforming to AWWA C900. Size range is 4-inches through 12-inches. PVC pipe may only be used by permission of the Engineering Manager. A written request to use PVC in lieu of CML&C steel must be submitted to the Engineering Manager and approved in writing.

1.02 PIPE IDENTIFICATION SYMBOLS

Interpret pipe identification symbols used on the Drawings as follows: PVC-8"-200 designates type of pipe (polyvinyl chloride); nominal pipe size (8-inches); and working pressure rating (Class 200).

1.03 REFERENCE STANDARDS

The publications listed below form part of this specification to the extent referenced and are referred to in the text by the basic designation only. Reference shall be made to the latest edition of said standards unless otherwise called for:

ASTM D1784	Standard Specification for Rigid Polyvinyl Chloride (PVC) Compounds and Chlorinated Polyvinyl Chloride (CPVC) Compounds
ASTM A307	Standard Specification for Carbon Steel Bolts and Studs, 60 000 PSI Tensile Strength
ASTM A563	Standard Specification for Carbon and Alloy Steel Nuts
ASTM B62	Standard Specification for Composition Bronze or Ounce Metal Castings
ASTM D1248	Standard Specification for Polyethylene Plastics Extrusion Materials For Wire and Cable
AWWA C110	Ductile-Iron and Gray-Iron Fittings, 3-inch through 48-inch, For Water and Other Liquids
AWWA C111	Rubber-Gasket Joints For Ductile-Iron Pressure Pipe and Fittings
AWWA C153	Ductile-Iron Compact Fittings, 3-inch through 16-inch, For Water and Other Liquids
AWWA C900	Polyvinyl Chloride (PVC) Pressure Pipe and Fabricated Fittings, 4-inch through 12-inch for Water Distribution

1.04 RELATED WORK SPECIFIED ELSEWHERE

RMWD	Standard Drawings
Section 02223	Trenching, Backfilling, and Compacting
Section 03300	General Concrete Construction
Section 09900	Painting and Coating
Section 15041	Disinfection of Piping
Section 15044	Pressure Testing of Piping

1.05 SUBMITTALS

- A. Submit shop drawings in accordance with Section 1 - General Conditions.
- B. Provide affidavit of compliance with AWWA C900.
- C. Submit copies of the following required tests conducted on the project pipe by the manufacturer:
 - 1. Quick-burst strength of pipe and couplings.
 - 2. Flattening resistance of pipe.
 - 3. Record of additional tests after test sample failure.
- D. Submit manufacturer's literature on ductile iron fittings conforming to AWWA C110 including dimensions, thickness, weight, coating, lining, and a statement of inspection and compliance with the acceptance tests of AWWA C110.
- E. Submit manufacturer's literature on ductile iron fittings conforming to AWWA C153 including dimensions, thickness, weight, coating, and lining. Submit certificate of compliance with AWWA C153. Include legible engineering analysis sealed by a registered professional engineer or test results confirming the hydrostatic design in accordance with Section 53-5.3 of AWWA C153 for each size and configuration of fitting to be supplied. Submit results of foundry tests required by AWWA C153 including chemical analysis per Section 53-13.
- F. Submit dimensions of push-on joints and other joints which do not conform to rubber-gasket joints in accordance with AWWA C111.
- G. Submit manufacturer's catalog data and descriptive literature for high deflection couplings, repair couplings, tracer wire, marking tape, and miscellaneous piping materials.

1.06 INSPECTION AND FIELD VERIFICATION

- A. The Engineering Manager may inspect materials, productions, and testing at manufacturer's plant.
- B. Where new pipelines are to be connected to existing waterlines of the District, the Contractor shall verify in the field the location, elevation, pipe material, pipe outside diameter, and any other characteristics of the existing waterline before proceeding with the pipe installation. This field verification shall be performed in the presence of the Engineering Manager.

PART 2 MATERIALS

2.01 PVC PIPE

Pipe shall be polyvinyl chloride (PVC) conforming to AWWA C900 with material cell classification 12454-8 per ASTM D 1784. Provide standard pipe having integral bell and spigot with elastomeric gasket and cast iron equivalent outside diameter. Provide pipe in standard 20-foot laying lengths. Straight pipe sections with plain ends for use with high deflection couplings are not available. Random lengths will not be permitted. Provide Class 200 pressure rating or as shown on the Drawings.

2.02 HIGH DEFLECTION COUPLINGS

High Deflection couplings shall be used only with the approval of the Engineering Manager. Provide polyvinyl chloride (PVC) or ductile iron (DI) couplings with twin elastomeric gaskets which allow 2 degrees of deflection at each gasket for a total of 4 degrees per coupling. Provide couplings for cast iron equivalent outside diameter. Couplings shall be selected from the Approved Materials List.

2.03 CLOSURE/REPAIR COUPLINGS

Provide polyvinyl chloride (PVC) couplings with twin elastomeric gaskets which are designed to connect plain ends of straight pipe. Provide couplings for cast iron equivalent outside diameter and Class 200 pressure rating. Do not deflect pipe in these couplings. Closure/Repair Couplings shall be selected from the Approved Materials List.

2.04 FITTINGS

- A. Provide ductile iron fittings conforming to AWWA C110 with a minimum rated working pressure of 350 psi. Provide fittings with bells and gaskets specifically designed for cast iron equivalent outside diameter PVC pipe. Use mechanical joint fittings or fittings with bells and gasket ends.
- B. Compact ductile iron fittings shall conform to AWWA C153 with a minimum rated working pressure of 350 psi. Provide fittings constructed of Grade 70-50-05 ductile iron having a minimum weight equal to the weight tabulated in AWWA C153. Provide fittings with bells and gaskets specifically designed for cast iron equivalent outside diameter PVC pipe. Use mechanical joint fittings or fittings with bells and gasket ends conforming to the dimensional values of AWWA C111. Mechanical joint glands shall be Grade 70-50-05 ductile iron and cast in one continuous ring. Fittings with repaired defects are not acceptable and will be rejected.

2.05 LINING AND COATING FOR FITTINGS

Line interior of fittings per Specification Section 15056.

2.06 FLANGES

Flanges on ductile iron fittings shall conform to AWWA C110 or ANSI B16.42 Class 150. Refer to Specification Section 15056.

2.07 BOLTS, NUTS AND GASKETS FOR FLANGES

- A. Provide stainless steel Type 316 bolts and nuts for buried flanges, unless otherwise specified on the plans or approved by the Engineering Manager.
- B. Provide washers for each nut. Washers shall be of the same material as the nuts.
- C. Gaskets shall be asbestos-free, drop-in ring type, 1/16-inch or 1/8-inch thick, and shall be acrylic or aramid fiber bound with nitrile. Gaskets shall be suitable for a water pressure of 500 psi at a temperature of 400°F. Select materials from Approved Materials List.

2.08 OUTLETS

- A. For outlets 2-inches and smaller with working pressures 150 psi or less, attach a service saddle and corporation stop to the pipe. Provide service saddles with full width, cast bronze bodies conforming to ASTM B 62, O-ring gaskets, and iron pipe threads. Provide Type 304 stainless steel double band straps with four bolts or a single wide strap with four bolts. All stainless steel shall be fully passivated for enhanced corrosion resistance. All saddles shall be pre-sized at the factory for installation on cast iron equivalent outside diameter PVC pipe conforming to AWWA C900. Service saddles shall be selected from the Approved Materials List
- B. For outlets 3-inches and larger, use a ductile iron tee with a flanged outlet.

2.09 FLEXIBLE PIPE COUPLINGS

Flexible pipe couplings shall be selected from the Approved Materials List.

2.10 FLANGE COUPLING ADAPTERS

Flange coupling adapters shall be selected from the Approved Materials List.

2.11 TRACER WIRE

- A. Tracer wire shall be installed over all waterlines and forced sewer mains made of nonmetallic material. Tracer wire shall be in a continuous strand, placed on top of pipe and secured with tape every 10 feet. Tracer wire shall be brought to the surface of all appurtenances and connected to an approved tracer box within the housekeeping pad. The only exception is for a meter service lateral. The wire will then loosely terminate within the meter box.
- B. The Contractor shall test the tracer wire in the presence of the Engineering Manager. If there is no continuity, the Contractor shall make the necessary repairs at their expense.
- C. Use AWG No. 14 stranded copper wire with high molecular weight polyethylene (HMW/PE) insulation specifically designed for direct burial in corrosive soil or water. Polyethylene insulation shall conform to ASTM D 1248, Type 3, Class C, and Grade 5.
- D. Wire nuts will be used to connect two ends and then placed in a silicone filled splice connector DBR-6 or approved equal.

2.12 WARNING / IDENTIFICATION

Use marking tape consisting of one layer of aluminum foil laminated between two colored layers of inert plastic film. The lamination bond shall be strong enough that the layers can not be separated by hand.

Tape shall be a minimum of 5 mils thick and 6-inches wide. Elongation shall be a minimum of 600%. Tape shall bear a continuous, printed, message every 16 to 36-inches warning of the installation buried below. Tape shall be selected from the Approved Materials List.

2.13 MARKER POSTS

When pipeline is located outside of paved street, provide marker posts for buried pipelines at 500 feet on center or as directed by the Engineering Manager. Use 6-inch diameter plastic posts, filled with cement grout and painted white with blue stenciled lettering indicating "WATER". See RMWD Standard Detail for Guard Posts.

PART 3 EXECUTION

3.01 PRODUCT MARKING

Legibly mark pipe in blue at 5-foot intervals and each coupling to identify the nominal pipe size, OD base, PVC, dimension ratio number and pressure class, AWWA C900, and the seal of the testing agency that verified the suitability of the material for potable water service.

3.02 DELIVERY AND TEMPORARY STORAGE OF PIPE

- A. Ship, store, and place pipe at the storage yard or installation site by supporting the pipe uniformly. Avoid scratching the pipe surface. Do not stack higher than 4 feet nor stack with weight on bells. Cover to protect from sunlight.
- B. Do not install pipe that is gouged or scratched forming a clear depression.
- C. Do not install pipe contaminated with a petroleum product (inside or outside).
- D. Do not install any pipe that shows evidence of exposure to sunlight, age, surface deterioration, or other physical damage. The decision of the Engineering Manager shall be final as to the acceptability of the pipe to be installed.

3.03 HANDLING OF PIPE

Lift pipes with mechanical equipment using wide belt slings or a continuous fiber rope which avoids scratching the pipe. Do not use cable slings or chains. Pipes up to 12-inches in diameter may be lowered by rolling on two ropes controlled by snubbing. Pipes up to 6-inches in diameter can be lifted by hand.

3.04 PREVENTING FOREIGN MATTER FROM ENTERING THE PIPE

At all times when pipe laying is not in progress, the open end of the pipe shall be closed with a tight-fitting cap or plug to prevent the entrance of foreign matter into the pipe. These provisions shall apply during the noon hour as well as overnight. In no event shall the pipeline be used as a drain for removing water which has infiltrated into the trench. The Contractor shall maintain the inside of the pipe free from foreign materials and in a clean and sanitary condition until its acceptance by the Engineering Manager.

3.05 PIPE LAYOUT FOR STRAIGHT AND CURVED ALIGNMENTS

- A. Use integral bell end pipe for straight alignments and for radii greater than 1,150 feet.

- B. Use the following various combinations of plain end pipe lengths with high deflection couplings and integral bell end pipe for curved alignments in both horizontal and vertical directions. Do not bend pipe between couplings. Saw cut integral bell end of standard pipe and bevel end for use with deflection couplings. Use 9.5-foot plain end pipe lengths with deflection couplings for all radii between 140 feet to 270 feet. Use 19-foot plain end pipe lengths with deflection couplings for all radii between 270 feet to 560 feet. Use an integral bell end pipe length joined together with a 19-foot plain end pipe length to form a chord. Use deflection couplings on each end of the chord and continue this combination through the curved alignment for all radii between 560 feet to 1,150 feet. Pipe lengths shorter than 9 feet will not be used unless specifically authorized by the Engineering Manager.

3.06 INSTALLING PIPE IN TRENCH

- A. See Specification Section 02223 for earthwork requirements.
- B. Inspect each pipe and fitting before lowering into the trench. Clean ends of pipe thoroughly. Remove foreign matter and dirt from inside of pipe and keep clean during and after laying.
- C. Handle pipe in a manner to avoid any damage to the pipe. Do not drag pipe over the ground, drop it onto the ground, or drop objects on it. Do not drop or allow pipe to fall into trenches.
- D. Laying tolerances for the installed pipe shall not vary greater than 0.3-foot horizontally, or greater than 0.1-foot vertically from the alignment and elevations shown on the Drawings.
- E. Grade the bottom of the trench to the line and grade to which the pipe is to be laid, with allowance for pipe thickness. Remove hard spots that would prevent a uniform thickness of pipe base material (imported sand). Before laying each section of the pipe, check the grade with a straightedge and correct any irregularities found. The trench bottom shall form a continuous and uniform bearing and support for the pipe at every point between bell holes, except that the grade may be disturbed for the removal of pipe handling slings.
- F. At the location of each joint, dig bell holes in the bottom of the trench and at the sides to permit visual inspection of the entire joint and to prevent the pipe from being supported by the bell end or fitting.
- G. Keep the trench in a dewatered condition during pipelaying. Removal of water shall be in conformance with Specification Section 02223.

3.07 ASSEMBLING PIPE JOINTS

- A. The spigot and integral bell or coupling shall be dirt free and slide together without displacing the rubber ring gasket. Lay the pipe section with the integral bell facing the direction of laying.
- B. Clean the groove of the bell or coupling of all foreign materials. If the gasket groove is dirty or contains debris, carefully remove the gasket and clean the groove. Insert the gasket back into the groove of the bell or coupling prior to installation. Observe the correct direction of the shaped gasket. Feel that the gasket is completely and evenly seated in the groove.

- C. Mark the full insertion depth on the spigot end of the pipe. This mark indicates when the pipe is fully inserted into toe bell or coupling. Lubricate the exposed gasket surface and the beveled spigot up to the full insertion mark with the lubricant supplied by the pipe manufacturer. For repair couplings, lubricate pipe for the entire distance the coupling will travel on the pipe. If the lubricated pipe end touches dirt, clean the pipe end and reapply lubricant.
- D. Insert the spigot into the bell or coupling and force it slowly into position.
- E. Check that the rubber ring gasket has not left the groove during assembly by passing a feeler gage around the completed joint.

3.08 INSTALLING BURIED FITTINGS

- A. The Engineering Manager will inspect all fittings prior to installation for damage to the interior protective coatings. Patch damaged areas in the field with material similar to the original.
- B. For mechanical joint fittings, clean the bell socket and the plain end of the pipe of all foreign material and dirt. Place the gland on the pipe spigot with the lip extension toward the plain end. Lubricate the pipe spigot and gasket. Use the same lubricant as supplied by the pipe manufacturer. Install the gasket on the pipe spigot with the narrow edge of the gasket toward the plain end. Insert the pipe into the bell socket and press the gasket firmly into the gasket recess. Keep the joint straight during assembly. Push the gland towards the socket and center it around the pipe with the gland lip against the gasket. Insert bolts and hand tighten nuts. Make joint deflection after assembly but before tightening bolts. Uniformly tighten bolts and nuts in a progressive diametrically opposite sequence, and torque nuts to 75- to 90-foot-pounds with a calibrated torque wrench.
- C. For push-on joint fittings, clean the bell ends of the fitting of all foreign material and dirt. Insert the gasket in the groove of the bell and make sure the gasket faces the correct direction. Feel that the gasket is completely and evenly seated in the groove. When pipe is cut in the field, bevel the plain end prior to installation. Lubricate the exposed gasket surface and the beveled pipe spigot with the same lubricant supplied by the pipe manufacturer. Insert the spigot into the bell and force it slowly into position. Keep the joint straight while pushing. Make joint deflection after the joint is assembled.
- D. When necessary to deflect pipe from a straight line in either the horizontal or vertical plane, do not exceed the following joint deflection angles for buried fittings. The angles shown are for **each joint of a ductile iron fitting** and are maximum deflection:

<u>Nominal Pipe Size (inches)</u>	<u>Joint Deflection (degrees)</u>
4	2
6	2
8	2
10	2
12	2

3.09 INSTALLING FLANGED JOINTS

- A. Clean bolts, nuts and flange faces by wire brushing before installing gasket and adjoining flange. Coat bolt shafts with waterproof gear grease or primer for wax tape coating prior to insertion in flange bolt holes. Do not apply grease or primer to threads. Lubricate threads of bolts and nuts

with oil or graphite prior to installation. Assemble all bolts and nuts in the flange, then uniformly tighten bolts and nuts in a progressive diametrically opposite sequence, and torque with a calibrated torque wrench. All clamping torque shall be applied to the nuts only.

- B. If flanges leak under pressure testing, loosen or remove the nuts and bolts, reset or replace the gasket, reinstall or retighten the bolts and nuts, and retest the joints. Joints shall be watertight. Replace galled, cracked, or distorted bolts and nuts.
- C. After testing, coat exposed surfaces of bolts and nuts to be buried with waterproof gear grease or primer for wax tape coating.

3.10 INSTALLING SERVICE SADDLES

- A. Service Saddles shall be installed at a 45% angle above the spring line of the pipe. Place the service saddle on the pipe and hand tighten the nuts while positioning the saddle in its final location. Uniformly tighten the nuts in a progressive diametrically opposite sequence and torque with a calibrated torque wrench to the saddle manufacturer's recommended values.
- B. Connect a corporation stop to the saddle per Specification Section 15100. Apply Teflon joint compound or tape to the male threads before installing the corporation stop. Make joints watertight.
- C. Mount a tapping machine on the corporation stop to cut a hole in the pipe with a shell type cutter made specifically for PVC pipe. Do not use other devices or hand equipment to bore through the pipe wall, unless approved by the Engineering Manager.

3.11 INSTALLING TRACER WIRE

Prior to backfill, install tracer wire on top of pipe and secure in place with 2-inch wide plastic adhesive tape at maximum 10-foot intervals. Maintain tracer wire on pipe centerline during trench backfill. Run tracer wire continuously along pipe. Tracer wire access ports shall be installed within the concrete splash pad of all fire hydrants or in a CP Test Box. A CP Test Box will be installed at the District's discretion every 1000-linear feet from where the appurtenance exists. All buried wires that require trenching to a test box location shall be installed without splice, in a conduit in the trench at a minimum 24-inch with warning tape 12-inches above pipe. Location of all tracer wire access ports installed shall be noted on the field drawings. Where buried splices occur, use an electrical splicing kit consisting of a split bolt connector, mold, and a two part encapsulating epoxy resin such as Scotch cast, or District approved equal. Provide 24-inches of coiled wire at access points for attachment of pipe locating equipment. Each installed run of pipe shall be capable of being located using the tracer wire. Protect wire insulation from damage during installation and backfilling. Wire insulation that is broken, cut, or damaged shall be replaced.

3.12 INSTALLING WARNING/IDENTIFICATION TAPE

After the pipe zone and the first 12-inches in the trench zone have been backfilled and compacted, place the marking tape on the compacted backfill and center over the pipe. Run tape continuously along the trench and tie ends of tape together. Wrap marking tape around valve box extension pipes and continue along pipe.

3.13 SETTING MARKER POSTS

Locate marker posts 5-feet off centerline of pipeline and space at 500-foot intervals. Paint post per Specification Section 09900. Use white paint for the finish coats. Stencil in 2-inch high blue letters the word "WATER" on the post. Excavate a hole 16-inches in diameter by 3-feet deep. Set the post plumb, fill hole with concrete to 2-inches above finish grade, and crown to slope away from post. Fill the post with cement grout and crown top. Paint top surface of grout when dry with blue paint. Concrete shall be per Specification Section 03300.

3.14 PRESSURE TESTING

See Specification Section 15044 for pressure testing requirements.

3.15 DISINFECTION

See Specification Section 15041 for chlorination requirements.

END OF SECTION 15064

SECTION 15070

**POLYVINYL CHLORIDE (PVC) DISTRIBUTION PIPE
(AWWA C905)**

PART 1 GENERAL

1.01 DESCRIPTION

This section includes materials, installation, and testing of polyvinyl chloride (PVC) distribution pipe conforming to AWWA C905. Size range is 14-inches through 24-inches with DR 18 pipe. Maximum working pressure will be limited to 150 psi, unless directed otherwise by the District. A written request to use PVC in lieu of CML&C steel must be submitted to the Engineering Manager and approved in writing.

1.02 PIPE IDENTIFICATION SYMBOLS

Interpret pipe identification symbols used on the Drawings as follows: PVC-14"-DR 18 designates type of pipe (polyvinyl chloride); nominal pipe size (14-inches); and dimension ratio (DR 18).

1.03 REFERENCE STANDARDS

AWWA C110	Ductile-Iron and Gray-Iron Fittings, 3-inch through 48-inch, for Water and Other Liquids
AWWA C111	Rubber-Gasket Joints For Ductile-Iron Pressure Pipe and Fittings
AWWA C153	Ductile-Iron Compact Fittings, 3-inch through 16-inch, for Water and Other Liquids
AWWA C905	Polyvinyl Chloride (PVC) Pressure Pipe and Fabricated Fittings, 14-inch through 48-inch for Water Transmission and Distribution
ASTM F477	Standard Specification for Elastomeric Seals (Gaskets) for Joining Plastic Pipe
ASTM D3139	Standard Specification for Joints for Plastic Pressure Pipes Using Flexible Elastomeric Seals
ASTM D1784	Standard Specification for Rigid Poly (Vinyl Chloride) (PVC) Compounds and Chlorinated Poly(Vinyl Chloride) (CPVC) Compounds
ASTM A307	Standard Specification for Carbon Steel Bolts and Studs, 60 000 PSI Tensile Strength
ASTM D1599	Standard Test Method for Resistance to Short-Time Hydraulic Failure Pressure of Plastic Pipe, Tubing, and Fittings
ASTM D2241	Standard Specification for Poly (Vinyl Chloride) (PVC) Pressure-Rated Pipe (SDR Series)
ASTM D2252	Standard Specification for Fineness of Types of Alpaca
ASTM D1248	Standard Specification for Polyethylene Plastics Extrusion Materials for Wire and Cable

1.04 RELATED WORK SPECIFIED ELSEWHERE

RMWD	Standard Drawings
Section 02223	Trenching, Backfilling, and Compacting
Section 03300	General Concrete Construction
Section 09900	Painting and Coating
Section 15041	Disinfection of Piping
Section 15044	Pressure Testing of Piping

1.05 SUBMITTALS

- A. Submit shop drawings in accordance with Section 1 - General Conditions.
- B. Provide affidavit of compliance with AWWA C905.
- C. Submit copies of the following required tests conducted on the project pipe by the manufacturer:
 - 1. Quick-burst strength of pipe.
 - 2. Flattening resistance of pipe.
 - 3. Impact resistance of pipe.
 - 4. Acetone-immersion test of pipe material.
 - 5. Internal pressure and vacuum tests of joints per ASTM D3139.
 - 6. Laboratory tests of gaskets per ASTM F477.
 - 7. Record of additional tests after test sample failure.
- D. Submit manufacturer's literature on ductile iron fittings conforming to AWWA C110 including dimensions, thickness, weight, coating, lining, and a statement of inspection and compliance with the acceptance tests of AWWA C110.
- E. Submit manufacturer's literature on ductile iron fittings conforming to AWWA C153 including dimensions, thickness, weight, coating, and lining. Submit certificate of compliance with AWWA C153. Include legible engineering analysis sealed by a registered professional engineer or test results confirming the hydrostatic design in accordance with Section 53-5.3 of AWWA C153 for each size and configuration of fitting to be supplied. Submit results of foundry tests required by AWWA C153 including chemical analysis per Section 53-13.
- F. Submit dimensions of push-on joints and other joints which do not conform to rubber-gasket joints in accordance with AWWA C111.
- G. Submit manufacture's catalog data and descriptive literature for tracer wire and marking tape.

1.06 INSPECTION AND FIELD VERIFICATION

- A. The Engineering Manager shall inspect materials, productions, and testing at manufacturer's plant.

- B. Where new pipelines are to be connected to existing waterlines of the District, the Contractor shall verify in the field the location, elevation, pipe material, pipe outside diameter, and any other characteristics of the existing waterline before proceeding with the pipe installation. This field verification shall be performed in the presence of the Engineering Manager.

PART 2 MATERIALS

2.01 PVC PIPE

Pipe shall be polyvinyl chloride (PVC) conforming to AWWA C905 with material cell classification 12454-B per ASTM D1784. Provide standard pipe having integral bell and spigot with elastomeric gasket and cast iron equivalent outside diameter. Provide pipe in standard 20-foot laying lengths. Straight pipe sections with plain ends for use with high deflection couplings are not available. Random lengths will not be permitted. Provide pipe with cast iron equivalent outside diameter and a dimension ratio (DR) of 18.

2.02 HIGH DEFLECTION COUPLINGS

Provide polyvinyl chloride (PVC) or ductile iron (DI) couplings with twin elastomeric gaskets which allow 2 degrees of deflection at each gasket for a total of 4 degrees per coupling. Provide couplings for cast iron equivalent outside diameter. Couplings shall be selected from the Approved Materials List.

2.03 FITTINGS

- A. Provide ductile iron fittings conforming to AWWA C110 with a minimum rated working pressure of 350 psi. Provide fittings with bells and gaskets specifically designed for cast iron equivalent outside diameter PVC pipe. Use mechanical joint fittings or fittings with bells and gasket ends.
- B. Compact ductile iron fittings shall conform to AWWA C153 with a minimum rated working pressure of 350 psi. Provide fittings constructed of Grade 70-50-05 ductile iron having a minimum weight equal to the weight tabulated in AWWA C153. Provide fittings with bells and gaskets specifically designed for cast iron equivalent outside diameter PVC pipe. Use mechanical joint fittings or fittings with bells and gasket ends conforming to the dimensional values of AWWA C111. Mechanical joint glands shall be Grade 70-50-05 ductile iron and cast in one continuous ring. Fittings with repaired defects are not acceptable and will be rejected.

2.04 LINING AND COATING FOR FITTINGS

Line interior of fittings per Specification Section 15056.

2.05 FLANGES

Flanges on ductile iron fittings shall conform to AWWA C110 or ANSI B16.42 Class 150. Refer to Specification Section 15056.

2.06 BOLTS, NUTS AND GASKETS FOR FLANGES

- A. Provide heavy hex, carbon steel bolts and nuts for buried flanges to be wrapped with polyethylene material. Bolts and nuts shall conform to ASTM A307 Grade B and ASTM A563 Grade A, respectively.

- B. Provide washers for each nut. Washers shall be of the same material as the nuts.
- C. Gaskets shall be asbestos-free, drop-in ring type, 1/16-inch or 1/8-inch thick, and shall be acrylic or aramid fiber bound with nitrile. Provide Garlock "Bluegard," Klinger "Klingersil C4400," or District approved equal. Gaskets shall be suitable for a water pressure of 500 psi at a temperature of 400°F.

2.07 OUTLETS

- A. For outlets 2-inches and smaller with working pressure 150 psi or less, attach a service saddle and corporation stop to the pipe. Provide service saddles constructed completely of Type 304 stainless steel. Saddles shall be a two piece, full circumference shell band bolted together with six bolts. Saddles shall have O-ring gaskets and outlets for iron pipe threads. All stainless steel shall be fully passivated for enhanced corrosion resistance. All saddles shall be sized for installation on cast iron equivalent outside diameter PVC pipe conforming to AWWA C905. Service saddles shall be Romac Industries Style 305, or District approved equal.
- B. For outlets 3-inches and larger, use a ductile iron tee with a flanged outlet.

2.08 FLEXIBLE PIPE COUPLINGS

Flexible pipe couplings shall be selected from the Approval Materials List.

2.09 FLANGE COUPLING ADAPTERS

Flange coupling adapters shall be selected from the Approved Materials List.

2.10 TRACER WIRE

Use AWG No.14 stranded copper wire with high molecular weight polyethylene (HMW/PE) insulation specifically designed for direct burial in corrosive soil or water. Polyethylene insulation shall conform to ASTM D1248, Type 3, Class C, Grade 5. Wires with cut or damaged insulation are not acceptable and replacement of the entire wire which has been damaged will be required at the Contractor's expense. Tracer wire shall be tested and verified by the Engineering Manager.

2.11 WARNING / IDENTIFICATION TAPE

Use marking tape consisting of one layer of aluminum foil laminated between two colored layers of inert plastic film. The lamination bond shall be strong enough that the layers can not be separated by hand. Tape shall be a minimum of 5 mils thick and 6-inches wide. Elongation shall be a minimum of 600%. Tape shall bear a continuous, printed message every 16 to 36-inches warning of the installation buried below. Tape shall be selected from the Approved Materials List.

2.12 MARKER POSTS

When pipeline is located outside of paved street, provide marker posts for buried pipelines at 500 feet on center or as directed by the Engineering Manager. Use 6-inch diameter schedule 40 steel pipe, filled with cement grout and painted white with blue stenciled lettering indicating "WATER.". See Standard Drawing W-13 for Guard Posts.

PART 3 EXECUTION**3.01 PRODUCT MARKING**

Legibly mark pipe at 5-foot intervals to identify the nominal pipe size, OD base, PVC, dimension ratio number and pressure class, AWWA C905, manufacturer's name and production code, and the seal of the testing agency that verified the suitability of the material for potable water service.

3.02 DELIVERY AND TEMPORARY STORAGE OF PIPE

- A. Ship, store, and place pipe at the storage yard or installation site by supporting the pipe uniformly. Avoid scratching the pipe surface. Do not stack higher than 4 feet nor stack with weight on bells. Cover to protect from sunlight.
- B. Do not install pipe that is gouged or scratched forming a clear depression.
- C. Do not install pipe contaminated with a petroleum product (inside or outside).
- D. Do not install any pipe that shows evidence of exposure to sunlight, age, surface deterioration, or other physical damage. The decision of the Engineering Manager shall be final as to the acceptability of the pipe to be installed.

3.03 HANDLING OF PIPE

Lift pipes with mechanical equipment using wide belt slings. Do not use cable slings or chains.

3.04 PREVENTING FOREIGN MATTER FROM ENTERING THE PIPE

At all times when pipe laying is not in progress, the open end of the pipe shall be closed with a tight-fitting cap or plug to prevent the entrance of foreign matter into the pipe. These provisions shall apply during the noon hour as well as overnight. In no event shall the pipeline be used as a drain for removing water which has infiltrated into the trench. The Contractor shall maintain the inside of the pipe free from foreign materials and in a clean and sanitary condition until its acceptance by the District.

3.05 PIPE LAYOUT FOR STRAIGHT AND CURVED ALIGNMENTS

- A. Use integral bell end pipe for straight alignments and for radii greater than 1,150 feet.
- B. Use the following various combinations of plain end pipe lengths with high deflection couplings and integral bell end pipe for curved alignments in both horizontal and vertical directions. Do not bend pipe between couplings. Saw cut integral bell end of standard pipe and bevel end for use with deflection couplings. Use 9.5-foot plain end pipe lengths with deflection couplings for all radii between 140 feet to 270 feet. Use 19-foot plain end pipe lengths with deflection couplings for all radii between 270 feet to 560 feet. Use an integral bell end pipe length joined together with a 19-foot plain end pipe length to form a chord. Use deflection couplings on each end of the chord and continue this combination through the curved alignment for all radii between 560 feet to 1,150 feet. Pipe lengths shorter than 9 feet shall not be used unless specifically authorized by the Engineering Manager.

3.06 INSTALLING PIPE IN TRENCH

- A. See Specification Section 02223 for earthwork requirements.
- B. Inspect each pipe and fitting before lowering into the trench. Clean ends of pipe thoroughly. Remove foreign matter and dirt from inside of pipe and keep clean during and after laying.
- C. Handle pipe in a manner to avoid any damage to the pipe. Do not drag pipe over the ground, drop it onto the ground, or drop objects on it. Do not drop or allow pipe to fall into trenches.
- D. Laying tolerances for the installed pipe shall not vary greater than 0.3-foot horizontally, or greater than 0.1-foot vertically from the alignment and elevations shown on the Drawings.
- E. Grade the bottom of the trench to the line and grade to which the pipe is to be laid, with allowance for pipe thickness. Remove hard spots that would prevent a uniform thickness of pipe base material (imported sand). Before laying each section of the pipe, check the grade with a straightedge and correct any irregularities found. The trench bottom shall form a continuous and uniform bearing and support for the pipe at every point between bell holes, except that the grade may be disturbed for the removal of pipe handling slings.
- F. At the location of each joint, dig bell holes in the bottom of the trench and at the sides to permit visual inspection of the entire joint and to prevent the pipe from being supported by the bell end or fitting.
- G. Keep the trench in a dewatered condition during pipelaying. Removal of water shall be in conformance with Specification Section 02223.

3.07 ASSEMBLING PIPE JOINTS

- A. The spigot and integral bell shall be dirt free and slide together without displacing the rubber ring gasket. Lay the pipe section with the integral bell facing the direction of laying.
- B. Clean the groove of the bell of all foreign materials. If the gasket groove is dirty or contains debris, carefully remove the gasket and clean the groove. Insert the gasket back into the groove of the bell prior to installation. Observe the correct direction of the shaped gasket. Feel that the gasket is completely and evenly seated in the groove.
- C. Mark the full insertion depth on the spigot end of the pipe. This mark indicates when the pipe is fully inserted into the bell. Lubricate the exposed gasket surface and the beveled spigot up to the full insertion mark with the lubricant supplied by the pipe manufacturer. If the lubricated pipe end touches dirt, clean the pipe end and reapply lubricant.
- D. Insert the spigot into the bell and force it slowly into position.
- E. Check that the rubber ring gasket has not left the groove during assembly by passing a feeler gauge around the completed joint.

3.08 INSTALLING BURIED FITTINGS

- A. The Engineering Manager will inspect all fittings prior to installation for damage to the interior protective coatings. Patch damaged areas in the field with material similar to the original.

- B. For mechanical joint fittings, clean the bell socket and the plain end of the pipe of all foreign material and dirt. Place the gland on the pipe spigot with the lip extension toward the plain end. Lubricate the pipe spigot and gasket. Use the same lubricant as supplied by the pipe manufacturer. Install the gasket on the pipe spigot with the narrow edge of the gasket toward the plain end. Insert the pipe into the bell socket and press the gasket firmly into the gasket recess. Keep the joint straight during assembly. Push the gland towards the socket and center it around the pipe with the gland lip against the gasket. Insert bolts and hand tighten nuts. Make joint deflection after assembly but before tightening bolts. Uniformly tighten bolts and nuts in a progressive diametrically opposite sequence, and torque nuts to 75 to 90-foot-pound with a calibrated torque wrench.
- C. For push-on joint fittings, clean the bell ends of the fitting of all foreign material and dirt. Insert the gasket in the groove of the bell and make sure the gasket faces the correct direction. Feel that the gasket is completely and evenly seated in the groove. When pipe is cut in the field, bevel the plain end prior to installation. Lubricate the exposed gasket surface and the beveled pipe spigot with the same lubricant supplied by the pipe manufacturer. Insert the spigot into the bell and force it slowly into position. Keep the joint straight while pushing. Make joint deflection after the joint is assembled.

3.09 INSTALLING FLANGED JOINTS

- A. Clean bolts, nuts and flange faces by wire brushing before installing gasket and adjoining flange. Coat bolt shafts with waterproof gear grease or primer for wax tape coating prior to insertion in flange bolt holes. Do not apply grease or primer to threads. Lubricate threads of bolts and nuts with oil or graphite prior to installation. Assemble all bolts and nuts in the flange, then uniformly tighten bolts and nuts in a progressive diametrically opposite sequence, and torque with a calibrated torque wrench. All clamping torque shall be applied to the nuts only.
- B. If flanges leak under pressure testing, loosen or remove the nuts and bolts, reset or replace the gasket, reinstall or retighten the bolts and nuts, and retest the Joints. Joints shall be watertight. Replace galled, cracked, or distorted bolts and nuts.

3.10 INSTALLING SERVICE SADDLES

- A. Place the service saddle on the pipe and hand tighten the nuts while positioning the saddle in its final location. Uniformly tighten the nuts in a progressive diametrically opposite sequence and torque with a calibrated torque wrench to the saddle manufacturer's recommended values.
- B. Mount a tapping machine on the corporation stop to cut a hole in the pipe with a shell type cutter made specifically for PVC pipe. Do not use other devices or hand equipment to bore through the pipe wall.

3.11 INSTALLING POLYETHYLENE ENCASEMENT

Wrap buried service saddles, fittings and flanged joints with polyethylene material. Complete the wrap prior to placing concrete anchors, supports, or thrust blocks per Specification Section 02223. Repair polyethylene material damaged during construction.

3.12 INSTALLING TRACER WIRE

Prior to backfill, install tracer wire on top of pipe and secure in place with 2-inch wide plastic adhesive tape at maximum 10-foot intervals. Run tracer wire continuously along pipe and terminate in adjacent valve boxes for buried assemblies or buried valves. Where buried splices occur, use an electrical

splicing kit consisting of a split bolt connector, mold, and two part encapsulating epoxy resin such as Scotchcast, or District approved equal. Provide 24-inches of coiled wire at access points for attachment of pipe locating equipment. Each installed run of pipe shall be capable of being located using the tracer wire. Protect wire insulation from damage during installation and backfilling. Wire insulation that is broken, cut, or damaged shall be replaced.

3.13 INSTALLING WARNING/IDENTIFICATION TAPE

After the pipe zone and the first 12-inches in the trench zone have been backfilled and compacted, place the marking tape on the compacted backfill and center over the pipe. Run tape continuously along the trench and tie ends of tape together. Wrap marking tape around valve box extension pipes and continue along pipe.

3.14 SETTING MARKER POSTS

Locate marker posts 5-feet off centerline of pipeline and space at 500-foot intervals. Paint post per Specification Section 09900. Use white paint for the finish coats. Stencil in 2-inch high blue letters the word "WATER" on the post. Excavate a hole 16-inches in diameter by 3 feet deep. Set the post plumb, fill hole with concrete to 2-inches above finish grade, and crown to slope away from post. Fill the post with cement grout and crown top. Paint top surface of grout when dry with blue paint. Concrete shall be per Specification Section 03300.

3.15 PRESSURE TESTING

See Specification Section 15044 for pressure testing requirements.

3.16 DISINFECTION

See Specification Section 15041 for chlorination requirements.

END OF SECTION 15070

SECTION 15076

CEMENT-MORTAR LINED AND COATED (CML&C) STEEL PIPE

PART 1 GENERAL

1.01 DESCRIPTION

This section designates the requirements for steel pipe fabrication, test in shop, installation of steel pipe, fabrication of steel sheet or plate, mill-manufactured steel pipe, bends, special pipes with outlets, pass holes, flanges and all other fittings. Steel pipe shall conform to the following except as modified by this Specification:

1.02 REFERENCE STANDARDS

The publications listed below form part of this specification to the extent referenced and are referred to in the text by the basic designation only. Reference shall be made to the latest edition of said standards unless otherwise called for:

AWWA C200	Steel Water Pipe 6-inches and larger
AWWA C205	Cement-mortar protective lining and coating
AWWA C207	Steel Pipe Flanges
AWWA C210	Coal-tar epoxy coating system for interior and exterior of steel water pipelines
AWWA C213	Fusion-Bonded epoxy coating for the interior and exterior of steel water pipelines
AWWA M11	Manual of water supply practices, steel pipe a guide for design and installation
AWS	Standard Qualification Procedure for Manual Welding Operators
ASME	Boiler and Pressure Vessel Code

1.03 RELATED WORK SPECIFIED ELSEWHERE

The publications listed below form part of this specification to the extent referenced and are referred to in the text by the basic designation only. Reference shall be made to the latest edition of said standards unless otherwise called for.

Section 09900	Painting and Coating
Section 15041	Disinfection of Piping

1.04 SUBMITTALS

The Contractor shall furnish submittals in accordance with Section 1 - General Conditions. Submittals are required for the following:

- A. Submit Shop Drawings, material lists, manufacturer's literature and catalog cuts of, but not limited to, the following:

Shop Drawings	Fabrication Details
Layout Schedule	Dimensional Checks
Manufacturer's tests	Protective Coatings
Mill Reports or Plant Test Reports	Welding Rods for Field Welding

- B. Shop Drawings shall be submitted and approved prior to manufacture of pipe. The layout schedule shall indicate the order of installation, the length and location of each pipe section and special, the station and elevation of the pipe invert at all changes in grade, and all data on curves and bends for both horizontal and vertical alignment.
- C. Submit data used by the Contractor in manufacture and quality control.
- D. Test reports showing the physical properties of the rubber used in the gaskets shall be submitted.

PART 2 MATERIALS

2.01 PIPING

- A. Steel pipe shall conform to AWWA C200. The steel for the cylinder shall be designed for a minimum of 300 psi working pressure and 36,000 psi minimum yield strength conforming to requirements for ASTM A36. Minimum pipe wall 1/4-inch thick.
- B. Fittings for steel pipe shall conform to the dimensions of AWWA C208 and shall be made of segmentally welded sections of hydrostatically tested pipe (same material and thickness), with ends compatible for type of joints shown. The minimum radius of elbows shall be 2.5 times the pipe diameter and the maximum miter angle on each section of elbow shall not exceed 11.25 degrees. Fittings shall be equal in pressure design strength and shall have the same lining and coating as the abutting pipe.
- C. Steel pipe joints shall be butt-strap, unless otherwise indicated. The straps shall be furnished in one or two sections, requiring two longitudinal welds in addition to the circumferential fillet welds. Provide steel flanges, welded to pipe where indicated. Flanges shall be in accordance with AWWA C207 Class F. Linings or coatings shall be continuous to the end of the pipe or back of the flange. Flange faces shall be shop cloth-inserted rubber. Bolts on buried flanges shall be Type 316 stainless steel with coal tar epoxy applied after installation.
- D. Cement mortar lining for steel pipes shall conform to the following:
 - 1. Except as otherwise provided in AWWA C205, the interior of all steel pipe, fittings and specials, shall be cleaned and lined in the shop with cement mortar lining applied centrifugally in conformance with AWWA C205. Every precaution shall be taken to prevent damage to the lining. If lining is damaged or found faulty at the construction site, the damage or unsatisfactory portions shall be replaced with lining conforming to these specifications.
 - 2. The pipe ends shall be left bare where field joints occur. Ends of the lining shall be left square and uniform. Feathered or uneven edges will not be permitted.

3. Defective linings as identified in AWWA C205 shall be removed from the pipe wall and shall be replaced to the full thickness required. Defective linings shall be cut back to a square shoulder in order to avoid feather-edged joints.
 4. 5-inch minimum hand holes shall be required, unless directed otherwise by the Engineering Manager, to facilitate interior lining repairs at all joints.
- E. Cement mortar coating for steel pipes shall conform to the following:
1. All buried pipe shall receive a ¾-inch thick reinforced cement mortar coating. The coating shall be reinforced with spirally wound No. 14 gauge steel wire spaced at 1½-inch centers positioned approximately at the center of the mortar coating. In lieu of a spirally wound wire, a wire mesh or wire fabric may be used. The mesh or fabric shall be fastened with welded wire clips or strips of metal so as to hold the wire approximately at the center of the mortar coating. Splices shall be lapped four inches and the free ends tied or looped to ensure continuity.
 2. After the welding is completed, the outside annular spaces between pipe sections shall be completely filled with grout. The grout shall be poured in such a manner that all exposed portions of the metal joint shall be completely protected with cement mortar. Grout used on the outside of joints shall be non-shrink grout, sufficiently fluid to permit it to be poured down one side of the pipe and allowed to flow up the other side. The outside mortar joints shall be properly formed by the use of heavy-duty diapers or grout bands.

2.02 STEEL BAR OR WIRE REINFORCEMENT

Circumferential steel bar or wire reinforcement shall conform to ASTM A615, Grade 60, "Specifications for Billet-Steel Bars for Concrete Reinforcement". Wire fabric reinforcing for cement-mortar coatings and linings of fittings shall conform to ASTM A185, "Specifications for Welded Steel Wire Fabric," or ASTM A497, "Specifications for Welded Deformed Steel Wire Fabric." Spiral-wire reinforcement for cement-mortar coatings shall conform to ASTM A82.

2.03 STEEL FOR JOINT RINGS

Steel for bell rings shall conform to ASTM A575, "Specification for Merchant Quality Hot Rolled Carbon Steel Bars." Steel for spigot rings shall conform to ASTM A576, "Specification for Special Quality Hot-Rolled Carbon Steel Bars."

2.04 MANUFACTURER'S TESTS

- A. Each steel cylinder with joint rings attached and cylinders for specials shall be hydrostatically tested to a circumferential stress of at least 22,000 psi, but not more than 25,000 psi. If leaks develop during testing, the cylinder shall be repaired by welding and retested until all leaks are eliminated.
- B. The seams in short radius bends and special fittings shall be tested by the air-soap method using air at a pressure of 5 psi or by the dye-check method. However, if the fitting is fabricated from cylinders which have been previously hydrostatically tested, no further test will be required on seams so tested.

- C. Hydrostatic testing of fittings to 150% of the design pressure may replace the tests described above. Any defects revealed by any of the alternate test methods shall be repaired by welding and the fitting retested until all defects have been eliminated.

2.05 FABRICATION DETAILS

- A. Each special and each length of straight pipe shall be plainly marked at the bell end to identify the design pressure and the proper location of the pipe or special by reference to layout schedule.
- B. Exposed portion of joint rings shall be protected from corrosion by the manufacturer's standard coating.

2.06 HANDLING AND SHIPMENT

Pipe and special fittings shall be handled carefully, and blocking and holddowns used during shipment shall prevent movement or shifting. Both ends of pipe and fittings on trucks or rail cars shall be bulkheaded or covered in order to prevent excessive drying of the interior lining.

PART 3 EXECUTION

3.01 INSTALLATION

- A. Trench Preparation: Earthwork shall be carried out in accordance with Specification Section 02223. Pipe laying shall be scheduled so that the bell end of the pipe faces in the direction of laying. Pipe installation on slopes steeper than 20% shall be laid in an uphill direction. Prior to laying the pipe, the bottom of the trench shall be graded and prepared to provide uniform bearing throughout the entire length of each joint of pipe. Suitable bell holes shall be excavated at each joint and a shallow lateral depression shall be scooped out half a pipe length from the last pipe laid to allow for easy removal of the belt pipe sling and thus avoid any movement of the pipe after it is placed on proper line and grade.
- B. Butt-Strap Closure Joints: Butt-strap closure joints shall be completed in the trench after the pipe has been laid to the alignment and grade shown on the Plans. They shall be field welded by full-circumferential fillet welds or one of the edges may be shop welded and the other field welded. Welding shall be done in the same manner as specified for welded joints.
1. The interior of the joints shall be filled with stiff plastic mortar and finished off smoothly with the inside of the pipe.
 2. Wire mesh, 2-inch by 4-inch by No. 13 gauge, clean, and free from rust, shall be applied to the exterior of the joints so that the wires on the 2-inch spacing run circumferentially around the pipe. The wires on the 4-inch spacing shall be crimped in such a manner that the mesh will be held 3/8-inch from the metal joint surface. The mesh shall be lapped a minimum of 8-inches and shall be securely wired in position.
 3. The joint exterior shall be coated with mortar to a minimum thickness of 1½-inches. Immediately prior to applying mortar to the interior or exterior of the joints, a cement wash shall be applied to the metal to be coated. A rust inhibitor paint shall be applied per Specification Section 09900 to all metal surfaces prior to coating with mortar.

C. **Welded Joints:** Welded joints shall be completed after the pipe is in final position. Welded joints shall be a lap-welded slip joint as shown on the Plans. Any recess between the bell and spigot shall be caulked with a rod to facilitate the welding. Pipe of 30-inches in diameter or more may be welded from the inside. Welders assigned to the Work shall be qualified under the AWS standard qualification procedure.

1. Joints to be welded shall be cleaned, preferably prior to placing the pipe in the trench, of all loose scale, heavy rust, paint, cement, and grease. At least a 1/2-inch recess shall be provided between adjacent mortar-covered surfaces to place the weld. In all hand welding, the metal shall be deposited in successive layers and the minimum number of passes or beads in the completed weld shall be as follows:

<u>Steel Cylinder Thickness (Inches)</u>	<u>Fillet Weld Minimum Number of Passes</u>
Smaller than 3/16 to 1/4	2
5/16	3
3/8	3

2. After the joints have been welded, the joint shall be grouted with cement mortar in the same manner as specified for rubber-ring joints.

3.02 PREVENTING FOREIGN MATTER FROM ENTERING THE PIPE

At all times when pipe laying is not in progress, the open end of the pipe shall be closed with a tight-fitting cap or plug to prevent the entrance of foreign matter into the pipe. These provisions shall apply during the noon hour as well as overnight. In no event shall the pipeline be used as a drain for removing water which has infiltrated into the trench. The Contractor shall maintain the inside of the pipe free from foreign materials and in a clean and sanitary condition until its acceptance by the Engineering Manager.

3.03 PRESSURE TEST

All pipelines shall be tested in accordance with Specification Section 15044. Zero leakage is allowed and all visible leaks must be repaired regardless of the results of the leakage allowance measurements.

3.04 DISINFECTION

Disinfection shall be in accordance with Specification Section 15041.

END OF SECTION 15076

SECTION 15100

VALVES

PART 1 GENERAL

1.01 DESCRIPTION

This section includes materials, testing, and installation of manually operated valves, check valves, air and vacuum valves, air-release valves, and combination air-release valves.

1.02 REFERENCE STANDARDS

The publications listed below form part of this specification to the extent referenced and are referred to in the text by the basic designation only. Reference shall be made to the latest edition of said standards unless otherwise called for:

ASTM A307	Standard Specification for Carbon Steel Bolts and Studs, 60 000 PSI Tensile Strength
ASTM A193	Standard Specification for Alloy-Steel and Stainless Steel Bolting Materials for High-Temperature Service
ASTM A194	Standard Specification for Carbon and Alloy Steel Nuts for Bolts for High-Pressure or High-Temperature Service, or Both
ASTM A126	Standard Specification for Gray Iron Castings for Valves, Flanges, and Pipe Fittings
ASTM A48	Standard Specification for Gray Iron Castings
ASTM A276	Specification for Hot- and Cold-Finished Bars of Stainless and Heat-Resisting Chromium-Nickel-Manganese Steel
ASTM B62	Standard Specification for Composition Bronze or Ounce Metal Castings
AWWA C105	Polyethylene Encasement For Ductile Iron Piping For Water And Other Liquids
AWWA C500	Gate Valves For Water And Sewerage Systems
AWWA C504	Rubber Seated Butterfly Valves
AWWA C509	Resilient Seated Gate Valves For Water And Sewerage Systems

1.03 RELATED WORK SPECIFIED ELSEWHERE

RMWD	Standard Drawings
Section 09900	Painting and Coating
Section 15041	Disinfection of Piping

1.04 SUBMITTALS

Contractor shall furnish submittals in accordance with the requirements of Section 1 - General Conditions. The following submittals are required:

- A. Submit Shop Drawings, manufacturer's catalog data and detail construction sheets showing all valve parts and describing material of construction by material and specification (such as AISI, ASTM, SAE, or CDA). Submittal shall include valve dimensions including laying lengths, dimensions and orientation of valve operators, as installed on the valves. Submittals shall also indicate valve linings and coatings with manufacturer's and paint numbers listed.
- B. For valves requiring certified tests, submit certified test results.

PART 2 MATERIALS

2.01 GENERAL

All valves shall be new and of current manufacture. Valves shall be furnished and installed by the Contractor at the location and in accordance with the type of ends as shown on the Plans and as herein specified.

The manufacturer shall have manufactured tight-closing valves of the valve type intended for use for a period of at least five (5) years.

The Contractor shall furnish and install each specific type of valve from a single manufacturer and use it throughout the Work.

All valves shall have a rated working pressure of at least 150 psi. All valves shall be certified to meet the test pressure as specified and shall have a rated working pressure that exceeds the full working pressure specified.

- A. Connections: Valves shall have flanged, hub, screwed, or special connector ends as shown on the Plans. Where not indicated, the valves shall have the same type of connection as the pipeline in which valves are to be installed and conform to the Specifications.
- B. Bolts, Nuts and Washers: Bolts, nuts and washers for aboveground installations shall be cadmium plated and shall conform to ASTM A307, Grade B, "Steel Machine Bolts and Nuts and Tap Holes," when a ring gasket is used and shall conform to ASTM A193, "Alloy-Steel Bolting Material for High Temperature Service", when a full-face gasket is used. Bolts and nuts shall be heavy hexagon series. Nuts shall conform to ASTM A194, "Carbon and Alloy Steel Nuts for Bolts for High Pressure and High Temperature Service" either in Grade 1, 2, or 2H. The fit shall be ANSI B1.1, "Unified Screw Threads," Class 2, except that Class 3 fit shall be used in holes tapped for studs. Threads may be made by either cutting or cold forming. Between 1/4-inch and 3/8-inch shall project through the nut when drawn tight.
 - 1. Bolts, nuts and washers for underground installations including below ground structures shall be type 316 stainless steel. All buried bolts shall be completely coated with Bitumastic No. 50, or approved equal, which must be applied in two coats to a minimum thickness of 15 mils per coat.
 - 2. All aboveground bolt threads shall be lubricated with graphite and oil. Flanged faces shall be wire brushed and cleaned prior to joining each flange.
- C. Polyethylene Encasement: Unless otherwise specified on the Plans, all valves for underground installation shall be encased in two layers of 8 mil polyethylene wrap in accordance with AWWA C105.
- D. Painting and Coating: All valves referenced in this section shall be painted and coated, interior and exterior, in accordance with Specification Section 09900.

2.02 PLUG VALVES - LUBRICATED OR NON-LUBRICATED

- A. The valves shall be lubricated, tapered plug valves, and shall be manufactured in the United States. The valves shall be a top entry, bolted gland design.

- B. Unless otherwise specified, valves shall have cast iron bodies and tapered plugs with bolted ductile iron, malleable iron, or steel covers depending on pressure rating of the valves. Valve castings shall be off the very highest quality obtainable. The segment gear shall have the valve stops welded prior to installation as directed by Engineering Manager. Weld repair of cast iron castings is not permissible.
- C. A ground valve plug shall be lapped to the body taper during the manufacturing process to establish an ultimate fit between these two items.
- D. The valves shall be supplied with a sealant system which allows application of a sealing media to the metallic valve seats as a means of establishing drip-tight sealing. The valve shall be furnished with a single point of application sealant system, and shall incorporate a double ball check valve between the sealant application point and the sealant system to eliminate the potential for leakage of line media to atmosphere. The sealant application point of the valves shall be a combination 1/2-inch black iron sealant screw which allows use of injection equipment or sealant sticks. The combination sealant screw shall be of a piston check design which minimizes debris collection. Ball check sealant fittings shall not be furnished.
- E. The valve shall be lubricated with a FDA and NSF approved lubricant suitable for potable water during installation. The lubricant shall be per the valve manufacturer's recommendation.
- F. A flexible, stainless steel diaphragm shall be provided under the valve cover, and shall bear against the top of the plug to provide a primary stem seal mechanism. The valve cover shall be sealed to the body by non-asbestos containing gaskets loaded in place by capscrews.
- G. A gland assembly shall be provided which shall control plug adjustment without working through compressible packing and shall not allow adjustment to be lost due to packing compression over time. Gland assembly shall have nitrile elastomer O-ring seals which bear against the plug shank and the valve cover as a provision for a secondary stem seal mechanism.
- H. Enclosed worm gear operators shall be furnished. Wrench operated valves shall be available when specified on certain smaller sized valves. Gear operators shall be an integral part of the valve design and shall provide for basic isolation of the valve adjustment gland, valve stops, etc., from the general environment. When specified, gearing shall be furnished as a tightly sealed waterproof design capable of withstanding 15-foot head of water, and such design shall also serve to totally protect the gland, and gland adjusting mechanism from the environment. Gearing shall consist of a ductile iron segment keyed to the valve stem.
- I. The segment shall be driven by a hardened steel worm gear. Both the segment and the worm gear shall be dry film lubricated with molybdenum disulfide. The worm gear shall be attached to an input shaft which is supported by thrust bearings. The gearing shall be lubricated by a high quality extreme pressure gear grease.
- J. Valve shall conform to Valve Manufacturer's Standardization Society Specification MSS SP-78; CAST IRON PLUG VALVES, FLANGED AND THREADED ENDS. The valve shall conform to the following standards, where applicable; ANSI B16.1, ANSI B1.20.1, ASTM-A 126, class B, MSS SP-6, MSS SP-25, and AWWA C110/A21.10-87. Face to face dimensions shall conform to ANSI B16.10.
- K. The valve manufacturer shall offer a five (5) year warranty against defects in materials and workmanship.
- L. The valves shall be a Venturi pattern design, and range in size from 8-inch to 24-inch. The valves shall be rated for a minimum working pressure of 400 psi Cold Working Pressure (CWP)

for sizes 6-inch to 12-inch, and 300 psi CWP for sizes 14-inch to 24-inch. The valves shall be hydrostatically shell pressure tested at twice the CWP rating. Each valve seat shall be tested at 150% CWP pressure in lieu of the SP-78 specified 110% CWP. The valve shall have flanged ends drilled to ANSI Class 250 Cast Iron Flange Templates.

- M. Lubricated plug valves shall be selected from the Approved Materials List.
- N. Non-Lubricated plug valves are acceptable.

2.03 RESILIENT WEDGE GATE VALVES

- A. All valves shall be new and of current manufacture. Resilient wedge valves may be used only for nominal pipe sizes from 3-inches to 24-inches in diameter, unless specified on the plans or approved by the Engineering Manager.
- B. Valves shall be furnished and installed with the type of ends shown on the Plans and as herein specified.
- C. Valves shall be manufactured to meet all applicable requirements of the latest edition of AWWA C509. Flange drilling shall be in accordance with ANSI B 16.1 standard for cast-iron flanges.
- D. Valves shall have non-rising stems, opening by turning counter-clockwise. Buried valves shall be provided with 2-inch square operating nut with arrow cast in metal to indicate direction of opening, and above ground valves shall be equipped with a handwheel. Valve stems shall be cast integral with stem collar and furnished of cast, forged, or rolled bronze. Stem nuts shall be independent of the wedge and shall be made of solid bronze. All body bolts shall be ANSI type 316 stainless steel.
- E. Cast-iron wedge shall have sealing surfaces of the wedge permanently bonded with resilient material to meet ASTM tests for rubber to metal bond ASTM D429. Each valve shall have a smooth unobstructed waterway free from any sediment pockets. Stuffing boxes shall be O-ring seal type with two rings located in stem above thrust collar. Low friction torque reduction thrust bearings shall be located both above and below the stem collar.
- F. Valves shall have hydrostatic shell test of 400 psi and shutoff test of 200 psi. At the 200 psi shutoff test the valve must be bubble tight - zero leakage will be allowed.

2.04 BALL VALVES - RUBBER SEATED

- A. Ball valve shall be of the tight-closing, shaft-mounted type which fully complies with AWWA Standard C507 latest edition. Valve design shall eliminate metal-to-metal contact or wedging in the sealing action. The valve shall be designed to provide drip-tight shutoff against flow in both directions. Design of valve shall be such that, with the valve in the open position, the full and unobstructed circular inlet and outlet port diameter shall be as specified in Table 2 of AWWA Standard C507. With the valve in the closed position, valve shall be drip-tight at rated pressure.
- B. The valve body shall have integral support legs or pads and shall consist of two body end pieces and a center body piece through-bolted and O-ring-sealed against leakage. All body pieces shall be of cast iron ASTM A126 Class B. Minimum body thickness shall be as specified in Table 3 of AWWA Standard C507. Unless otherwise specified, flanges shall be flat-faced, and flange drilling shall be in accordance with ANSI B16.1 standard for cast iron flanges.

- C. The valve ball shall be constructed of cast iron ASTM A48, Class 40, and shall be taper-pinned to an upper and lower fitted shaft of 18-8 Type 316 stainless steel that is turned, ground and polished to a 32 micro-inch or smoother finish per ANSI B46.1. Valves employing chromium plated iron or steel shafts or trunnions are not acceptable.
- D. The center section shall be fitted with sleeve-type bearings contained in the body hubs. Bearings shall be corrosion resistant and self lubricating, with minimum wall thickness of 1/4-inch. Material shall be teflon-lined with fiberglass backing. Bearing surfaces shall be isolated from flow by O-ring type seals. The ball assembly shall consist of a stainless steel stud and thrust collar in a grease-packed cavity.
- E. All seats shall be of a synthetic rubber compound. Seats shall be retained in the valve body by mechanical means without retaining rings, segments, screws or hardware of any kind in the flow stream. Seats shall seal a full 360° without interruption and have a plurality of grooves mating with a spherical stainless steel seating surface on the ball. Valve seats shall be field adjustable around the full 360° circumference and replaceable without dismantling the operator, ball or shaft. Where line size permits, seats shall also be capable of being replaced or adjusted without removing the valve from the line. There shall be two (2) sets of ball and body seats to provide drip-tight closure in both directions. Manufacturer shall certify that the rubber seat is field adjustable and replaceable.
- F. Ball valve shall be subjected to hydrostatic, shop leakage and performance tests as specified in Section 5.2 of AWWA Standard C507.
- G. Valve actuator shall conform to the operating requirements of AWWA Standard C507 and shall be designed to hold the valve in any intermediate position between full open and full closed without creeping or fluttering. Unless otherwise specified on the Plans the valve shall be equipped with a manual actuator of the self-locking type with mechanical stop-limiting devices to prevent over travel of the ball in the open or closed position with handwheel and position indicator for non-buried service. For buried service the valve shall be equipped with a 2-inch operating nut. Manual actuator shall be Pratt MDT or approved equal. Where cylinder actuators are specified, they shall be Pratt MDT with Dura-Cyl cylinder, or approved equal.
- H. The manufacturer furnishing the valve(s) shall certify that the valve(s) meet the requirements of AWWA Standard C507.

2.05 AIR RELEASE AND VACUUM RELIEF VALVES

All assemblies shall be as shown on the Standard Drawings or as detailed on the plans. Valves and fittings shall equal or exceed the pressure rating of the pipe to which they are attached. The valve shall be a combination type and shall be a minimum of 1-inch in size. Air release and vacuum relief valves shall be selected from the Approved Materials List.

- A. Air and vacuum valves shall be capable of venting sufficient quantities of air as determined by the manufacturer's approved sizing methods, while pipelines are being filled and allowing air to re-enter while pipelines are being drained.
- B. Air and vacuum valves shall be of the size indicated, with flanged or screwed ends to match the piping.
- C. Bodies shall be of high-strength cast iron or ductile iron.
- D. The float, seat, and all moving parts shall be constructed of Type 316 stainless steel.

- E. Seat washers and gaskets shall be of material insuring water tightness with a minimum of maintenance.
- F. Valves shall be designed for minimum 250 psi working pressure, unless otherwise indicated.
- G. Combination air/vacuum assemblies shall be installed on a section of pipe no closer than 18 inches to a bell, coupling, joint or fitting.
- H. Air/vacuum assemblies and valve box assemblies shall be field coated with safety yellow paint according to Specification Section 09900, unless specified on the plans or approved by the Engineering Manager.
- I. All assemblies shall be installed above ground.
- J. Assemblies shall be installed with a sanitary vent screen to the exhaust port of the valve, and selected from the Approved Materials List.
- K. Assemblies installed will have an isolation valve to permit future maintenance. Isolation valves installed above ground will have the capability to be locked out. Isolation valves installed below ground will be required to have a debris cap with a locking device.

2.06 CORPORATION STOPS

Corporation stops shall be manufactured of bronze conforming to ASTM B62. The inlet fitting shall be a male iron pipe thread when used with a saddle and the outlet connection shall be a compression or female iron pipe thread.

2.07 HOSE BIBBS AND VALVES

Hose bibbs shall be furnished and installed in the locations shown on the Plans and shall be of the sizes required. They shall be brass hose valves, with National Standard threads, cap, and chain.

PART 3 EXECUTION

3.01 INSTALLATION

- A. Flanges shall be cleaned by wire brushing before installing flanged valves. Flange bolts and nuts shall be cleaned by wire brushing, and threads lubricated with NSF 61 approved product. Nuts shall be tightened uniformly and progressively. If flanges leak under pressure testing, nuts and bolts shall be loosened or removed, the gasket reseated or replaced, the bolts and nuts reinstalled or retightened, and joints retested. Joints shall be watertight.
- B. Threaded joints shall be cleaned by wire brushing or swabbing. Teflon joint compound or Teflon tape shall be applied to pipe threads before installing threaded valves. Joints shall be watertight.

3.02 VALVE PRESSURE TESTING

Valves shall be tested at the same time that the connecting pipelines are pressure tested and in accordance with Specification Section 15044. Any parts of valves, operators, or control and instrumentation systems whose pressure rating is less than the test pressure shall be isolated and protected.

END OF SECTION 15100

SECTION 15101**RESILIENT SEATED GATE VALVES****PART 1 GENERAL****1.01 DESCRIPTION**

This section includes materials, installation, and testing of manually operated, resilient seated gate valves including accessories, linings, coatings, valve boxes, extension stems, anchors, and marker posts. Size range is 3-inches through 24-inches.

1.02 REFERENCE STANDARDS

The publications listed below form part of this specification to the extent referenced and are referred to in the text by the basic designation only. Reference shall be made to the latest edition of said standards unless otherwise called for:

AWWA C515	Reduce-Wall, Resilient-Sealed Gate Valves
ASTM A395	Ferritic Ductile Iron Pressure-Retaining Castings
ASTM A536	Ductile Iron Castings
ASTM B763	Copper Alloy Sand Castings for Valve Applications
ASTM F593	Stainless Steel Bolts
AWWA C900	PVC Pressure Pipe and Fabricated Fittings

1.03 RELATED WORK SPECIFIED ELSEWHERE

RMWD	Standard Drawings
Section 02223	Trenching, Backfilling and Compacting
Section 03300	Cast-in-Place Concrete
Section 09900	Painting and Coating
Section 09954	Polyethylene Sheet or Tube Encasement
Section 09961	Fusion-Bonded Epoxy Lining and Coating
Section 13110	Corrosion Control for Buried Piping
Section 15041	Disinfection of Piping and Water Storage Facilities
Section 15044	Pressure Testing of Piping

1.04 SUBMITTALS

- A. Submit submittal packages in accordance with Section 1 - General Conditions.
- B. Submit valve manufacturer's catalog data, descriptive literature, and assembly drawings. Show dimensions, materials of construction by specification reference and grade, linings, and coatings.

- C. Submit manufacturer's affidavit of compliance with referenced standards.
- D. Submit coating application test records for measuring coating thickness and holiday detection for the valve interior linings and exterior coatings. Describe repair procedures used.
- E. Submit valve box manufacturer's catalog data. Show dimensions and materials of construction.

PART 2 MATERIALS

2.01 GENERAL

- A. Provide valves complete with operating handwheel or operating nut, linings, coatings, valve box, extension stem, anchor, and marker post.
- B. Cast or mold onto the valve body or bonnet the name of the manufacturer and the valve size. Do not attach identification plates to the valve body or bonnet.
- C. Provide valves with the same type ends as the pipe or fittings, or with ends that have been designed for use on the pipe being installed.
- D. Unless otherwise indicated, valves shall be the same size as the pipe in which they are installed.
- E. Unless otherwise indicated, valves shall have a working pressure rating not less than the pipe in which they are installed.

2.02 RESILIENT SEATED GATE VALVES, 3-INCHES THROUGH 12-INCHES

For working pressures from zero to 250 psi, valves shall be resilient seated, non-rising stem and conform to the requirements of AWWA C515. Provide valves with resilient wedge disc, unobstructed waterway, counter-clockwise opening and designed for a working pressure of 250 psi. Construct valves of ductile iron conforming to ASTM A395 or A536. Bronze for internal working parts, including stems, shall not contain more than 2% aluminum nor more than 7% zinc, bronze shall be ASTM B763 Alloy C99500, except that stem bronze shall have a minimum tensile strength of 60,000 psi, a minimum yield strength of 30,000 psi, and a minimum of 12% elongation in 2-inches. Provide O-ring seals. Provide Type 304 or 316 stainless steel body bolts conforming to ASTM F593. Provide 2-inch AWWA operating nut for buried installations. Provide handwheel for aboveground or in vault installations. Gate valves shall be American Flow Control Series 2500, U.S. Pipe Metroseal 250, or approved equal.

2.03 RESILIENT SEATED GATE VALVES, 14-INCHES THROUGH 24-INCHES

For working pressures from zero to 250 psi, valves shall be resilient seated, non-rising stem and conform to the requirements of AWWA C515. Provide valves with resilient wedge disc, unobstructed waterway, counter-clockwise opening and designed for a working pressure of 250 psi. Construct and provide valves as described in paragraph 2.02. Provide bevel or worm gear operator. Gate valves shall be American Flow Control Series 2500, U.S. Pipe Metroseal 250, or approved equal.

2.04 LINING AND COATING FOR VALVES

Coat interior and exterior ferrous surfaces of the valves with fusion-bonded per Specification Section 09961. Do not coat bronze, rubber, or stainless steel items. Coating shall be holiday free on interior surfaces in contact with water.

2.05 PACKING, O-RINGS, AND GASKETS

Unless otherwise stated; packing, O-rings, and gaskets shall be one of the following nonasbestos materials.

- A. Teflon.
- B. Kevlar aramid fiber.
- C. Acrylic or aramid fiber bound by nitrile. Provide Garlock "Bluegard," Klinger "Klingersil C4400," or District approved equal.
- D. Buna-N (Nitrile).

2.06 VALVE BOXES

- A. Provide a valve box for each buried potable water valve consisting of a frame, cover, and one-piece extension pipe. Construct frame and cover of cast iron and design for traffic loading. Castings shall be smooth, clean, and free from blisters, blowholes, and shrinkage. Machine bearing surfaces of frame and cover to provide a close fit without rocking. Cast on the cover the words "RMWD" and "WATER". Frame and cover shall be South Bay Foundry SBF 1208-N, or District approved equal. Extension pipe shall be 8-inch diameter, polyvinyl chloride (PVC), plastic irrigation pipe (PIP) conforming to Soil Conservation Service specification SCS 430DD with a pressure rating of 100 psi, a pipe stiffness dimension ratio (SDR) of 41, and an outside diameter of 8.160-inches.
- B. Provide a valve box for each buried recycled water valve consisting of a frame, cover, and one-piece extension pipe. Construct triangular shaped frame and cover of cast iron and design for traffic loading. Castings shall be smooth, clean, and free from blisters, blowholes, and shrinkage. Machine bearing surfaces of frame and cover to provide a close fit without rocking. Cast frame into a circular precast concrete body section. Cast on the cover the words "RMWD" and "RW". Frame and cover shall be J&R Concrete Products, Inc. No. V4-T or District approved equal. Extension pipe shall be 8-inch diameter, polyvinyl chloride (PVC), conforming to AWWA C900, Class 150, and an outside diameter of 9.05-inches.

2.07 EXTENSION STEMS

Where the valve operating nut is more than 2 feet below the valve box cover, provide an extension stem to bring the operating nut to a point 6-inches below the surface of the cover. Construct stem of steel using pipe, bar stock, and plates to the dimensions shown on the Standard Drawings. Field verify required stem length prior to fabrication. Hot dip galvanize completed stem after fabrication.

2.09 POLYETHYLENE ENCASEMENT

See Specification Section 09954.

2.10 CORROSION CONTROL COMPONENTS

See Specification Section 13110.

2.11 ANCHORS

Provide anchors on valves that have non-restrained joints or that are installed with pipe having non-restrained joints. Anchor type depends on valve size and working pressure as shown in the Standard Drawings and shall be one of the following installations.

- A. Provide steel anchor straps and bolts, or reinforcing steel. Hot dip galvanize steel straps and bolts after fabrication. Completely encase in concrete after placing on valve.
- B. Provide reinforced concrete anchor and adapter with thrust collar. Design and sizing of the anchor will be based on the highest pressure the main will be subjected to, such as test or surge.

2.12 MARKER POSTS

Provide a marker post for each buried valve except where valve is located in a paved street. Use construction heart garden grade redwood per Standard Specifications for Grades of California Redwood Lumber issued by the Redwood Inspection Service. Provide seasoned redwood, 4-inches by 4-inches, and surfaced on four sides.

PART 3 EXECUTION**3.01 INSPECTION BEFORE INSTALLATION**

- A. Operate the valve from closed to fully open, then close again before installing. Check for broken, cracked, or missing parts; malfunctioning stem; scored surfaces on interior lining; and faulty operation.
- B. The District's Representative will conduct in the field an independent inspection of the lining and coating for compliance with the criteria in Specification Section 09961. Coated items failing his inspection will be cause for rejection.

3.02 INSTALLATION

- A. Prior to installing the valve in its final location, clean the interior of the valve of all contaminants and place valve in a closed position.
- B. Check all body bolts on the valve for tightness. Handle valve carefully and do not damage linings and coatings. Repair any or all damage to the satisfaction of the Engineering Manager.
- C. Install the valve per the piping instructions contained in the appropriate Standard Specification for the material used. Do not use valve to force the pipeline into position. Support piping to avoid line stresses on the valve. Do not deflect valve pipe joints.

3.03 INSTALLING POLYETHYLENE ENCASEMENT

Wrap buried valves, flanged joints, mechanical joints, flanged pipe spools with thrust collars, and adapters with polyethylene material per Specification Section 09954. Complete the wrap prior to placing concrete anchor blocks. Repair polyethylene material damaged during construction.

3.04 INSTALLING ANCHORS

Install concrete anchors over valves or around thrust collars after completion of the polyethylene encasement. Place concrete per Specification Section 02223.

3.05 INSTALLING VALVE BOXES

- A. Place and compact trench backfill to the height of the valve stem. Set the one piece extension pipe over the operating nut and center in place. Maintain the extension pipe in a vertical position during backfilling. Slip the valve box frame over the extension pipe and adjust both to finish grade. Pour a concrete ring around the valve box frame. Concrete shall be Class C per Specification Section 03300. In paved areas, top of concrete ring shall be 1-inch below finish grade of adjacent surfaces. In non-paved areas, top of valve box frame and concrete ring shall be flush with the natural or finish grade. Where paved, overlay the concrete ring with 1-inch compacted thickness of asphalt concrete pavement. Valve box frame and cover shall be flush with the finish surface of the pavement.
- B. Terminate tracer wire where installed in valve boxes as shown in the Standard Drawings. Secure tracer wire to the exterior surface of the extension pipe with plastic adhesive tape. Drill a hole at the top of the extension pipe for wire entry and provide 24-inches of coiled wire.

3.06 SETTING MARKER POSTS

Locate marker post as directed by the District's Representative. Cut redwood post to a 5-foot length and chamfer the top. Paint post per Specification Section 09900, System No. 60. Use white paint for the finish coats and blue or purple paint for the top 4-inches of the chamfered end. Excavate a hole 16-inches in diameter by 2 feet deep. Set the redwood post plumb, fill hole with concrete to 2-inches above finish grade, and crown to slope away from post. On the side facing the valve box, stencil on the post in 2-inch-high blue or purple letters the word "WATER" or the abbreviation "RW" and the distance in feet from the marker post to the valve box. Concrete shall be Class C per Specification Section 03300.

3.07 PAINTING AND COATING

- A. Coat valves located aboveground, or in vaults and structures, the same as the adjacent pipes and per Specification Section 09900. Do not apply flame spray coating to fusion-bonded epoxy coated valves. Apply finish coats in the field. Color of finish coat shall match the color of the adjacent piping. Coat handwheels the same as the valves.
- B. Paint top side of valve box covers per Specification Section 09900, System No. 20. Color of finish coat shall be as follows:
 - 1. Normally open inline or branch valve is OSHA Blue for potable water or purple for reclaimed water.

2. Branch valve to a fire hydrant assembly is OSHA Yellow.
3. Branch valve to one or more water service assemblies is OSHA White.
4. Normally closed inline or branch valve is OSHA Red.

3.08 FIELD TESTING

Operate gate valves through 10 full cycles of opening and closing. Valves shall operate from full open to full close without sticking or binding. If valves stick or bind, repair or replace the valve and repeat the tests.

3.09 PRESSURE TESTING

Test gate valves at the same time that the connecting pipelines are pressure tested. See Specification Section 15044 for pressure testing requirements. Repair leaks in the gate valves and joints of the interconnecting piping and retest.

3.10 DISINFECTION

See Specification Section 15041 for chlorination requirements.

END OF SECTION 15101

SECTION 15109

FIRE HYDRANT ASSEMBLIES

PART 1 GENERAL

1.01 DESCRIPTION

This section includes the materials for and installation of fire hydrant assemblies.

1.02 REFERENCE STANDARDS

The publications listed below form part of this specification to the extent referenced and are referred to in the text by the basic designation only. Reference shall be made to the latest edition of said standards unless otherwise called for:

AWWA C210	Liquid Epoxy Coating Systems for the Interior and Exterior of Steel Water pipelines
AWWA C213	Fusion Bonded Epoxy Coating for the Interior and Exterior of Steel Water Pipelines
AWWA C503	Wet-Barrel Fire Hydrants
AWWA C550	Protective Epoxy Interior Coatings for Valves and Hydrants

1.03 RELATED WORK SPECIFIED ELSEWHERE

RMWD	Standard Drawings
Section 03300	Cast-in-Place Concrete
Section 05550	Misc. Metals
Section 09900	Painting and Coating
Section 15041	Disinfection of Pipe
Section 15044	Hydrostatic Testing of Pressure Pipe
Section 15056	Ductile Iron Pipe and Fittings
Section 15076	CML&C Steel Pipe

1.04 SYSTEM DESCRIPTION

- A. Hydrant outlet sizes and configuration shall be as shown on the Approved Plans or as directed by the fire department of jurisdiction.
- B. Hydrants shall generally have the following number and size of outlets as directed by the fire department of jurisdiction:
 - 1. Residential: 2 1/2-inch outlet and one (1) 4-inch outlet
 - 2. Commercial: Two (2) 2 1/2-inch outlets and one (1) 4-inch outlet.
 - 3. Industrial: One (1) 2 1/2-inch outlet and two (2) 4-inch outlets.

1.05 SERVICE APPLICATION

Wet-barrel hydrants shall generally be used for pressures up to 200psi. System pressures up to and including 150psi requires standard wet-barrel hydrants, and pressures up to 200psi require high-pressure wet-barrel hydrants in accordance with the Approved Materials List. Fire hydrants with higher pressure ratings will be specified where required on the plans or as specified by the Engineering Manager.

1.06 DELIVERY, STORAGE AND HANDLING

Fire hydrants shall be delivered and stored in accordance with AWWA C210, AWWA C213, and AWWA C550. The port openings shall be covered with plastic, cardboard or wood while in transit and during storage in the field. These covers shall remain in place until the valve is ready to be installed. Fire hydrants shall not be stored in contact with bare ground. Fire hydrants shall not be stacked.

1.07 MASONRY RETAINING WALLS

If the above ground portion of the assembly is located within a cut slope or embankment fill, a masonry retaining wall shall be constructed on three sides around the assembly per Standard Drawing W-16. The face of wall shall be a minimum of one foot beyond the dimensional values of the concrete pad to be poured for the assembly as shown on the Standard Drawings. Use tan colored slump block and grout each cell solid. The concrete pad to be poured around the assembly shall extend to the face of the three walls and also to the adjacent sidewalk or curb. The Engineering Manager will decide whether the requirements of this paragraph are being followed by the Contractor. If in the opinion of the Engineering Manager modifications or changes are necessary, the work shall be performed as directed.

PART 2 MATERIALS**2.01 HYDRANTS**

- A. Fire hydrants and appurtenances shall be selected from the Approved Materials List.
- B. Wet-barrel fire hydrants shall comply with AWWA C503 and these specifications unless otherwise indicated on the Standard Drawings.
- C. All outlets shall be provided with National Standard Fire-Hose Threads. Outlets shall be equipped with brass or ductile iron caps with chains.
- D. Wet-barrel fire hydrant flanges and appurtenant bury ells and spools shall incorporate a six-hole bolt pattern.
- E. No Dry Barrel fire hydrants shall be used in Rainbow Municipal Water District.

2.02 BOLTS AND NUTS

Hydrant flange bolts and nuts shall be carbon steel conforming to ASTM A307 and selected from the Approved Materials List. For working pressures below 300 psi, bolts shall be the Break Off type with the threads facing up and filled with silicone, for pressures above 300 psi, as specified on the plans or approved by the Engineering Manager.

2.03 CONCRETE

Concrete used for splash pads, thrust or anchor blocks shall be in accordance with Specification Section 03300.

2.04 WARNING / IDENTIFICATION TAPE

Use marking tape consisting of one layer of aluminum foil laminated between two colored layers of inert plastic film. The lamination bond should be strong enough that the layers can not be separated by hand. Tape shall be a minimum of 5 mils thick and 6-inches wide. Elongation shall be a minimum of 600%. Tape shall bear a continuous, printed, message every 16 to 36-inches warning of the installation buried below. Tape shall be selected from the Approved Materials List.

2.05 FIELD PAINTING AND COATING

Field painting and coating materials shall be in accordance with Specification Section 09900.

PART 3 EXECUTION**3.01 GENERAL**

- A. Fire hydrant assemblies shall be installed at locations shown on the Approved Plans or as directed by the fire department of jurisdiction in accordance with the Standard Drawings.
- B. The location and port orientation of the Fire Hydrant shall be in accordance with the Standard Drawings and as required by the Fire Department.
- C. Fire hydrant flange bolts shall be set with nuts on top; torque nuts uniformly and progressively in accordance with the manufacturer's recommendations.
- D. Depending on location, fire hydrant assemblies may require protection posts or concrete retaining walls. When required by the Engineering Manager, or when shown on the Approved Plans, protection posts or retaining walls shall be installed in accordance with the Standard Drawings.

3.02 CONCRETE

Concrete thrust and anchor blocks shall be installed in accordance with Specification Section 03300 and the Standard Drawings. Refer to Specification Section 03300 for the minimum concrete curing time required.

3.03 WARNING/IDENTIFICATION TAPE

After the pipe zone and the first 12-inches in the trench zone have been backfilled and compacted, place the marking tape on the compacted backfill and center over the pipe. Run tape continuously along the trench and tie ends of tape together. Wrap marking tape around valve box extension pipes and continue along pipe.

3.04 DISINFECTION OF FIRE HYDRANT

The fire hydrant assembly shall be disinfected in accordance with Specification Section 15041, as part of the process of disinfecting the main pipeline. The assembly valves shall be operated and the assembly flushed to completely disinfect all internal parts.

3.05 HYDROSTATIC TESTING

Fire hydrant assemblies shall be hydrostatically tested in accordance with Specification Section 15044 in conjunction with the pipeline to which it is connected.

3.06 FIELD PAINTING AND COATING

The fire hydrant exterior shall be field painted in accordance with Specification Section 09900.

END OF SECTION 15109

SECTION 15112

BACKFLOW PREVENTION ASSEMBLIES

PART 1 GENERAL

1.01 DESCRIPTION

This section includes materials, installation, and testing of backflow prevention assemblies and detector check assemblies. Assemblies shall be installed at the locations as shown on the Drawings or as established in the field by the Engineering Manager.

1.02 REFERENCE STANDARDS

The publications listed below form part of this specification to the extent referenced and are referred to in the text by the basic designation only. Reference shall be made to the latest edition of said standards unless otherwise called for:

AWWA C511	Reduced Pressure Principal Backflow Prevention Assembly
ANSI B16.1	Cast Iron Pipe Flanges and Flanged Fittings Classes 25, 125, and 250
ASTM A536	Standard Specification for Ductile Iron Castings
ASTM B584	Standard Specification for Copper Alloy Sand Castings for General Applications
ASTM B61	Standard Specification for Steam or Valve Bronze Castings
ASTM B62	Standard Specification for Composition Bronze or Ounce Metal Castings
ASTM A307	Standard Specification for Carbon Steel Bolts and Studs, 60 000 PSI Tensile Strength
ASTM A563	Standard Specification for Carbon and Alloy Steel Nuts

1.03 RELATED WORK SPECIFIED ELSEWHERE

RMWD	Standard Drawings
Section 1 - General Conditions	Record Drawings and Submittals
Section 02223	Trenching, Backfilling, and Compacting
Section 03300	General Concrete Construction
Section 09900	Painting and Coating
Section 15041	Disinfection of Piping
Section 15044	Pressure Testing of Piping

1.04 SUBMITTALS

- A. Submit shop drawings in accordance with Section 1 – General Conditions.
- B. Submit manufacturer's catalog data, descriptive literature, and assembly drawings. Show dimensions, materials of construction by specification reference and grade, linings, and coatings.
- C. Submit manufacturer's certificate of compliance with AWWA C511 for reduced pressure principle backflow prevention assemblies.

1.05 MASONRY RETAINING WALLS

If the aboveground portion of the assembly is located within a cut slope or embankment fill, a masonry retaining wall shall be constructed on three (3) sides around the assembly per Standard Drawing W-16.

The face of wall shall be a minimum of one (1) foot beyond the dimensional values of the concrete pad to be poured for the assembly as shown on the Standard Drawings. Use tan colored slump block and grout each cell solid. The concrete pad to be poured around the assembly shall extend to the face of the three walls and also to the adjacent sidewalk or curb. The Engineering Manager will decide whether the requirements of this paragraph are being followed by the Contractor. If in the opinion of the Engineering Manager modifications or changes are necessary, the work shall be performed as directed.

1.06 PRIVATE PUMPING FACILITIES

The addition of a backflow prevention assembly to any given size water service assembly will reduce the available water service pressure. The owner may opt to install a larger size water service and backflow prevention assembly at their expense to provide adequate water service pressure. The District will not provide pumping facilities to increase water service pressure. Private pumping facilities shall be independent and located downstream of backflow prevention assemblies.

1.07 THERMAL EXPANSION

The addition of a backflow prevention assembly to a water service will constitute a closed system. The District will not provide thermal expansion facilities for this condition. Provide sufficient facilities for thermal expansion and check for proper operation of existing thermal or pressure relief devices.

PART 2 MATERIALS

2.01 MANUFACTURERS

Provide backflow prevention assemblies of the described type that are on the Approved Materials List.

2.02 BACKFLOW PREVENTERS

- A. General: Backflow prevention devices shall be the same size as and never smaller than the upstream water service assembly. Where normal minimum water service pressure is less than 80 psi; the District may require the next larger assembly size.
- B. Backflow prevention devices of the reduced pressure principle type shall conform to AWWA C511 with a maximum rated working pressure of 175 psi for operation on cold water pipelines. Provide two (2) independently acting check valves, an automatic pressure differential relief valve located between the check valves, two (2) resilient seated shutoff valves at each end of the assembly, and four (4) resilient seated test cocks so that a test of each check valve can be made. Check valves and the differential relief valve shall be constructed for servicing without removing the assembly from the line. Backflow prevention devices 2-inches and smaller, per Standard Drawing W-1 shall be bronze conforming to ASTM B61 or B62. Backflow prevention devices larger than 2-inches, per Standard Drawing W-2, shall have ductile iron bodies and covers conforming to ASTM A536 Grade 65-45-12. All internal working parts and relief valve shall be bronze conforming to ASTM B584 with stainless steel trim.
- C. Backflow prevention devices 2-inches and smaller, shall be of the conventional in-line design for installation in a horizontal position with the relief valve discharging vertically down. Resilient seated shutoff valves and test cocks shall be full ported, bronze ball valves.
- D. Backflow prevention devices 3-inches through 10-inches, shall be of the conventional in-line design for installation in a horizontal position. Shutoff valves shall be resilient seated gate valves with outside stem and yoke. Test cocks shall be full ported, bronze ball valves. Provide adjustable pipe supports to augment the installation to prevent flange damage.

- E. The degree of hazard and property size will determine the type of backflow preventer. A Reduce Pressure device would be required for high hazard regardless of property size and for low hazard properties larger than ½ an acre. The Cross Connection Control Specialist will determine the degree of hazard and will require the appropriate device.

2.03 LINING AND COATING OF ASSEMBLIES

Coat interior and exterior ferrous surfaces of the backflow preventers and detector checks with fusion-bonded epoxy per Specification Section 09900. Do not coat bronze, rubber, or stainless steel items.

2.04 VALVE END CONNECTIONS

- A. Valves, 2-inches and smaller, shall have screwed ends. Valves, 2-1/2-inches and larger, shall have flanged ends.
- B. Screwed ends shall conform to ANSI B1.20.1, NPT.
- C. Flanged ends shall conform to ANSI B16.1, Class 125.

2.05 PACKING, O-RINGS, AND GASKETS

Unless otherwise stated; packing, O-rings, and gaskets shall be one of the following non-asbestos materials.

- A. Teflon.
- A. Kevlar aramid fiber.
- C. Acrylic or aramid fiber bound by nitrile. Provide Garlock "Bluegard," Klinger "Klingersil C4400," or District approved equal.
- D. Buna-N (Nitrile).

2.06 BOLTS, NUTS AND GASKETS FOR FLANGES

- A. Provide heavy hex, SST 316 bolts and nuts for aboveground flanges and buried flanges to be wrapped with polyethylene material. Bolts and nuts shall conform to ASTM A316 Grade B and ASTM A563 Grade A, respectively.
- B. Provide washers for each nut. Washers shall be of the same material as the nuts.
- C. Gaskets shall be asbestos-free, full face, 1/16-inch or 1/8-inch thick, and shall be acrylic or aramid fiber bound with nitrile. Provide Garlock "Bluegard," Klinger "Klingersil C4400," or District approved equal. Gaskets shall be suitable for a water pressure of 500 psi at a temperature of 400°F.

2.07 VALVE SETTERS

Provide valve setters to augment the installation of the compact design ("N" series) detector checks. Valve setters shall be constructed with integral support arms between the elbows to transfer thrust downstream. Construct valve setters of ductile iron conforming to ASTM A536 Grade 65-45-12. Coat interior and exterior surfaces of the ductile iron with fusion-bonded epoxy. End connections shall be a

combination of flanged ends and mechanical joints as shown on the Standard Drawings. Flanged ends shall conform to ANS B16.1 Class 125. Valve setters shall be Cla-Val Model VS, Febco Model 611, or District approved equal.

2.08 ADJUSTABLE PIPE SUPPORTS

Provide adjustable pipe support of welded steel construction with fusion-bonded epoxy coating. Locate the pipe supports under flanges or valve bodes as shown. Provide 2-inch galvanized steel pipe, cut to length, and place between the collar and base. Provide Material Resources "Standon Pipe Support Model S-89," or District approved equal.

2.9 GUARD POSTS

Provide guard posts shall be installed around the assembly per Standard Drawings W-13.

PART 3 EXECUTION

3.01 INSPECTION BEFORE INSTALLATION

Operate the shutoff valves and test cocks on the assemblies from closed to fully open, then close again before installing. Check for broken, cracked, or missing parts; malfunctioning stems; and faulty operation.

3.02 INSTALLATION

- A. See Specification Section 02223 for earthwork requirements. Use imported sand in the pipe base and pipe zone.
- B. Install piping and riser section per the instructions contained in the appropriate Standard Specification for the material used.
- C. Piping from the main to the backflow prevention assembly shall be placed level or on a continuous upward grade to avoid pocketing air. No outlets will be allowed in the piping between the main and the assembly. Trench backfilling shall not commence until the Engineering Manager has inspected this section of piping and is satisfied with the installation.
- D. Install backflow prevention assemblies in a horizontal position, aboveground, and at the dimensions shown on the Standard Drawings. Locate the assemblies where shown or as established in the field by the Engineering Manager. The Engineering Manager shall be the final authority as to location, installation, size, and type of backflow prevention assembly required.
- E. Clean threaded joints by wire brushing or swabbing. Apply Teflon joint compound or Teflon tape to pipe threads before installing screwed valves. Joints shall be watertight.
- F. Clean bolts, nuts and flange faces by wire brushing before installing flanged assemblies. Inspect gasket seating surfaces, gasket, each stud or bolt, nut, and washer. Replace any damaged item. Coat bolt shafts with waterproof gear grease or primer for wax tape coating prior to insertion in flange bolt holes. Do not apply grease or primer to threads. Lubricate threads of bolts and nuts with oil or graphite prior to installation. Assemble all bolts and nuts in a progressive diametrically opposite sequence, and torque with a calibrated torque wrench. All clamping torque shall be applied to the nuts only.
- G. If flanges leak under pressure testing, loosen or remove the nuts and bolts, reset or replace the gasket, reinstall or retighten the bolts and nuts, and retest the joints. Joints shall be watertight. Replace galled, cracked, or distorted bolts and nuts.

- H. After testing, coat exposed surfaces of bolts and nuts to be buried with waterproof gear grease or primer for wax tape coating.

3.03 INSTALLING POLYETHYLENE ENCASEMENT

Wrap ferrous pipe risers including base bends and valve setters with polyethylene material. Complete the wrap prior to placing concrete anchor blocks or concrete trust blocks on base bends or valve setters. Repair polyethylene material damaged during construction.

3.04 PLACING CONCRETE

Place concrete anchor blocks around the elbow of the pipe riser or valve setter. Where a thrust block is required, place concrete against the base bends and undisturbed ground. Place concrete back to back between the base bends. Allow concrete to set and be hard enough to be self-supporting. Place and compact trench backfill up to the subgrade of the concrete pad on grade. Pour a concrete pad on grade around the pipe risers. Concrete shall be per Specification Section 03300.

3.05 SETTING GUARD POSTS

Position guard posts to protect the backflow prevention assembly. Locate posts as directed by the Engineering Manager. Excavate a hole 16-inches in diameter by 3-feet deep for each post. Set posts plumb, fill holes with concrete to 2-inches above finish grade, and crown to slope away from post. Posts shall be embedded a minimum of 3 feet in concrete. Fill posts with grout and crown top. Concrete shall be Class C per Specification Section 03300.

3.06 PAINTING AND COATING

- A. Paint aboveground surfaces of the pipe risers, elbows or bends, and adjustable pipe supports per Specification Section 09900. Color of finish coat shall be OSHA Blue. Do not paint backflow prevention assemblies.
- B. Paint above ground surfaces of the guard posts per Specification Section 09900. Color of finish coat shall be OSHA Yellow.

3.07 PRESSURE TESTING

Test backflow prevention assemblies at the same time that the connecting pipelines are pressure tested. See Specification Section 15044 for pressure testing requirements. Repair leaks in the backflow prevention assemblies and joints of the interconnecting piping and retest.

3.08 DISINFECTION

See Specification Section 15041 for chlorination requirements.

3.09 INITIAL TESTING

Backflow prevention assemblies will not be placed into service until the appurtenance has been tested and certified by a certified backflow tester. The results shall be submitted to the Engineering Manager for final approval.

END OF SECTION 15112

SECTION 15125

OPEN TRENCH PIPE CASING

PART 1 GENERAL

1.01 DESCRIPTION

This section includes materials for and installation of open trench pipe casings. Jacked casings or specially-installed pipe casings shall be installed as detailed in Specification Section 15130.

1.02 REFERENCE STANDARD

The publications listed below form part of this specification to the extent referenced and are referred to in the text by the basic designation only. References shall be made to the latest edition of said standards unless otherwise called for:

ASTM A361	Standard Specification for Carbon Structural Steel
ASTM A283	Standard Specification for Low and Intermediate Tensile Strength Carbon Steel Plates
ASTM A568	Standard Specification for Steel, Sheet and Strip, Carbon, Hot-Rolled, and Structural Quality Cold Rolled
AWWA C905	Standard for Polyvinyl Chloride (PVC) Water Transmission Pipe, 14-inch through 36-inch

1.03 RELATED WORK SPECIFIED ELSEWHERE

RMWD	Standard Drawings
Section 02223	Trenching, Backfilling and Compacting
Section 15043	Testing of Gravity Sewer
Section 15044	Hydrostatic Testing of Pressure Pipe
Section 15076	CML&C Steel Pipe and Specials

1.04 SERVICE APPLICATION

Generally, pipe casings are used for protection of utilities (carrier pipes) and may be installed for future utility installations. Pipe casings shall be used for the installation of potable water, reclaimed water, and sewer mains where shown on the Approved Drawings or as required by the Engineering Manager.

1.05 DESIGN REQUIREMENTS

- A. Pipe casings shall be provided for carrier piping where shown on the Approved Drawings or as required by the Engineering Manager. The sizes and material type for pipe casing shall be as detailed in Part 2 of this Section.
- B. The Engineering Manager may select a greater steel thickness and diameter as appropriate for the intended application.

1.06 SUBMITTALS

The following items shall be submitted for review and approval by the Engineering Manager prior to the start of the casing work:

- A. Casing pipe
- B. Casing spacers and end seals
- C. Installation procedure
- D. Method of restraint to be used for the casing and carrier pipes
- E. Welding procedure
- F. Cathodic Protection

1.07 DELIVERY, STORAGE AND HANDLING

- A. PVC pipe casing shall be stored in suppliers' yards and on the job site in accordance AWWA M23 and the manufacturer's recommendations. PVC pipe casing which has been subjected to excessive ultraviolet radiation from the sun shall not be used. The determination as to the acceptability of PVC pipe casing faded by the sun's radiation shall rest solely with the Engineering Manager.
- B. Store PVC pipe casing in the field by the supporting the pipe uniformly per AWWA M23. Do not stack pipe higher than 4-inch high or stack the pipe with weight on the bell ends. Cover stored PVC pipe casing to protect it from the sun's ultraviolet radiation. Pipe which has been contaminated with any petroleum products (inside or outside) shall not be installed.
- C. Proper care shall be used to prevent damage in handling, moving and placing the pipe casing. All pipe casing materials shall be lowered into the trench in a manner that prevents damage. The pipe casing shall not be dropped, dragged or handled in a manner that will cause bruises, cracks, or other damage.

1.08 CASING SPACERS AND END SEALS

Casing spacers and end seals shall be used for all carrier pipe installations within casings.

PART 2 MATERIALS

2.01 PIPE CASING

- A. Pipe casing materials shall be as indicated below and shall be selected from the Approved Materials List. The size of the pipe casings required for the various sizes of carrier pipe is as follows:

Carrier Pipe Size	Minimum Casing Size	Carrier Pipe Size	Minimum Casing Size
6"	14"	16"	30"
8"	16"	20"	36"
10"	18"	24"	42"
12"	20"		

- B. Pipe Casing for Carrier Pipe larger than 24-inch shall be as determined by the Engineering Manager.
- C. Polyvinyl Chloride Pipe (PVC) casings shall be as follows:
 - 1. Casing pipe sizes 14-inch through 36-inch shall be in accordance with AWWA C905, pressure rated 235.
 - 2. The color for PVC casing pipe shall be blue or white for potable water carrier pipe.
- D. Steel Pipe casings shall be as follows:
 - 1. Steel pipe casings, unless otherwise approved by the Engineering Manager, shall be butt-welded sheets (spiral welding of pipe not allowed) conforming to ASTM A36/A36M, ASTM A283/A283M, Grade D, or ASTM A568/A568M, Grade 33. Other steel grades may be used upon approval of the Engineering Manager. Steel casings sized 20-inch or smaller shall have a minimum wall thickness of 3/8-inch. Steel casings sized larger than 20-inch shall have a minimum wall thickness of 1/2-inch).
 - 2. Steel pipe casings shall not be lined or coated with any material unless otherwise directed by the Engineering Manager.

If required, steel pipe casing shall be lined and coated with liquid epoxy paint per AWWA C210. Liquid epoxy shall be applied in three coats to a minimum thickness of 0.012-inch or 12 mils. The final coat of the liquid epoxy shall be blue for potable water.
 - 3. Steel pipe casings shall include the installation of an anode in accordance with the Standard Drawings, unless otherwise directed by the Engineering Manager.

2.02 CASING SPACERS

Casing spacers shall be stainless steel, centered-position type with PVC liner and non-metallic anti-friction runners selected from the Approved Materials List.

2.03 CASING END SEALS

Casing end seals, selected from the Approved Materials List, shall wrap around the casing and carrier pipe to provide a barrier to backfill material and seepage. The casing end seal shall be a minimum 1/4-inch thick styrene butadiene rubber sheet attached to the carrier pipe and casing with 1-inch wide stainless steel bands. Zippered casing end seals with stainless steel bands may also be used.

2.04 WARNING / IDENTIFICATION TAPE

Use marking tape consisting of one (1) layer of aluminum foil laminated between two (2) colored layers of inert plastic film. The lamination bond shall be strong enough that the layers can not be separated by hand. Tape shall be a minimum of 5 mils thick and 6-inches wide. Elongation shall be a minimum of 600%. Tape shall bear a continuous, printed, message every 16 to 36-inches warning of the installation buried below. Tape shall be selected from the Approved Materials List.

PART 3 EXECUTION**3.01 TRENCH EXCAVATION, BACKFILL AND COMPACTION**

Trenching, bedding, backfilling and compaction operations shall be performed in accordance with Specification Section 02223.

3.02 DEWATERING

- A. The Contractor shall provide, and maintain at all times during construction, ample means and devices to promptly remove and dispose all water from any source entering trench excavations or other parts of the work in accordance with Specification Section 02223. Any damage caused by flooding of the trench shall be the Contractor's responsibility.
- B. Dewatering shall be performed by methods that will maintain a dry excavation, preservation of the final lines and grades and protection of all utilities. If flooding of the trench does occur, the Contractor shall immediately dewater and restore the trench. Damaged or altered pipeline appurtenances or trench materials shall be repaired or replaced as directed by the Engineering Manager.

3.03 PIPE CASING INSTALLATION

Installation of pipe casing and carrier pipe shall be as described below and in accordance with the Standard Drawings.

- A. Pipe casing shall be installed in an open trench type excavation.
- B. Pipe casings shall be lowered onto the bedding of the proper lines and grades called for on the Approved Plans.
- C. Pipe casings shall have firm bearing along their full length.
- D. Pipe casing sections shall be bell and spigot joint connection for PVC. PVC casing sections shall be restrained by mechanical means or by the use of splined gaskets. Steel casing sections shall be jointed by full-circumference butt welding in the field. Steel casing shall have all areas of damaged coating repaired.
- E. Carrier pipe shall be pushed into the casing incorporating the use of casing spacers as described below.
- F. PVC or ductile-iron carrier pipe joints shall be restrained either by mechanical means or by use of splined gaskets.
- G. Steel carrier pipe sections shall be lap joint welded per Specification Section 15076.
- H. Upstream and downstream elevations of the carrier pipe shall be verified prior to installing the end seals.
- I. The portion of carrier pipes installed within casings shall have pressure, leakage, and infiltration testing completed in accordance with Specification Sections 15043 and 15044 prior to installation of the end seals.

- J. The annular space between the carrier pipe and casing shall not be filled with any material unless otherwise noted on the Approved Plans.

3.04 CASING SPACERS

Casing spacers shall be used to prevent the carrier pipe bell from touching the casing and to maintain a uniform space between the carrier pipe and casing interior. A minimum of three (3) casing spacers shall be installed equally spaced, on each pipe section at intervals recommended by the manufacturer. Casing spaces shall be selected in accordance with the Approved Materials List.

3.05 CASING END SEALS

Casing end seals shall be installed in accordance with the manufacturer's recommendations. Carrier pipe shall pass hydrostatic or leakage tests in accordance with Specification Sections 15043 or Section 15044 prior to the installation of casing end seals or backfilling operations.

3.06 WARNING/IDENTIFICATION TAPE

After the pipe zone and the first 12-inches in the trench zone have been backfilled and compacted, place the marking tape on the compacted backfill and center over the pipe. Run tape continuously along the trench and tie ends of tape together. Wrap marking tape around valve box extension pipes and continue along pipe.

END OF SECTION 15125

SECTION 15130

JACKED PIPE CASING

PART 1 GENERAL

1.01 DESCRIPTION

This section includes materials and installation of jacked pipe casings. Where the contractor proposes to install pipelines using directional drilling or boring, a complete submittal of the methods and materials shall be made to the Engineering Manager prior to the initiation of the work.

1.02 REFERENCE STANDARDS

The publications listed below form part of this specification to the extent referenced and are referred to in the text by the basic designation only. References shall be made to the latest edition of said standards unless otherwise called for.

ASTM A361	Standard Specification Steel Sheet Zinc Coated
ASTM A283	Standard Specification Carbon Steel Subjected to the Sulphidation Process
ASTM A568	Standard Specification for Steel, Sheet and Strip, Carbon, Hot-Rolled, and Structural Quality Cold Rolled

1.03 RELATED WORK SPECIFIED ELSEWHERE

RMWD	Standard Drawings
Section 02223	Trenching, Backfilling and Compacting
Section 15043	Testing of Gravity Sewer
Section 15044	Hydrostatic Testing of Pressure Pipe
Section 15076	CML&C Steel Pipe and Specials

1.04 SERVICE APPLICATION

Generally, pipe casings are used for protection of utilities (carrier pipes) and may be installed for future utility installations. Pipe casings shall be used in conjunction with the installation of potable water and sewer mains in areas shown on the Approved Plans or as directed by the Engineering Manager.

1.05 PROTECTION OF EXISTING UTILITIES AND FACILITIES

The contractor shall be responsible for the care and protection in place of all existing utilities, facilities, and structures that may be encountered in or near the area of the work.

1.06 SAFETY AND PERMITTING REQUIREMENTS

- A. Pipe jacking and boring projects 30-inch in diameter or larger are required to be classified by the State of California, Department of Industrial Relations, Division of Occupational Safety and Health.

- B. Protection of workers in trench excavation shall be as required by the State of California Construction Safety Orders, the State of California State Health and Safety Code, the requirements of CAL-OSHA.
- C. All excavations shall be performed, protected, and supported as required for safety and in the manner set forth in the operation regulations prescribed by CAL-OSHA.
- D. It shall be the Contractor's responsibility to obtain excavation permits, traffic control permits, or other applicable permits from the local agency which has jurisdiction.
- E. A pre-job safety conference with representatives of the Division of Occupational Safety, CAL-OSHA, the District, the Contractor and Contractor's employees shall be held before the work begins.
- F. Contractors performing this type of work are required to hold a current C-34 or General Engineering Contracting License from the State of California.

1.07 DESIGN REQUIREMENTS

- A. Pipe casing shall be provided for the carrier piping where shown on the Approved Plans or as required by the Engineering Manager. The sizes and material type for pipe casing shall be as detailed in Part 2 of this Section.
- B. The Engineering Manager may select a greater steel thickness and diameter as appropriate for the intended application.

1.08 SUBMITTALS

The contractor shall provide to the Engineering Manager and the agency, or agencies, of jurisdiction a drilling, boring, and jacking plan prior to commencing boring operations. The submittal shall include:

- A. Configuration of the jacking pits and jacking pit bracing or shoring. Pit excavations deeper than 20 feet require the shoring system to be certified by a Registered Civil Engineer.
- B. The pipe casing material to be used. Include pipe material type, wall thickness, and welding details.
- C. Casing spacers and end seals.
- D. Jacking plan and profile drawing detailing the placement of the jacked casing.
- E. Installation procedure.
- F. Manufacturer and type of liquid epoxy paint, including proposed steel preparation and application methods to be used.
- G. The jacking machinery and jacking head proposed to be used.
- H. Summary of the backfilling method to be used.
- I. Worker Protection and Safety Plan.

J. Cathodic Protection.

1.09 DELIVERY AND HANDLING

Proper care shall be used to prevent damage in handling, moving and placing the pipe casing. All pipe-casing materials shall be lowered into the trench in a manner that prevents damage. The pipe casing shall not be dropped, dragged or handled in a manner that will cause dents, cracks, or other damage to the pipe casing.

1.10 CASING SPACERS AND END SEALS

- A. Casing spacers and end seals shall be used for all pipe installations within casings.
- B. If the carrier pipe is not installed within the casing as a continuous operation following completion of jacking, then bulkhead the portals and backfill the approach trenches. Bulkheads will be removed at a later time to allow for the installation of the carrier pipe.

PART 2 MATERIALS

2.01 PIPE CASINGS

- A. Jacked pipe casings shall be steel. The minimum size and wall thickness of jacked steel pipe casings shall be as follows, unless otherwise required by the agency having jurisdiction over the road, utilities, or improvements:

<u>Carrier Pipe Size</u>	<u>Minimum Casing Size</u>	<u>Min. Steel Casing Wall Thickness</u>
6"	14"	3/8"
8"	16"	3/8"
10"	18"	3/8"
12"	20"	3/8"
16"	30"	1/2"
20"	36"	1/2"
24"	42"	1/2"

- B. Pipe casing for carrier pipe sizes larger than 24-inch shall be determined by the Engineering Manager.
- C. The Contractor may submit a greater steel thickness and diameter as appropriate for the method of work and loadings involved, as suitable for the site and as limited by possible interferences. The Contractor shall submit any deviations in the approved design to the Engineering Manager fourteen (14) working days in advance of jacking operations, and may not proceed with any work until the Engineering Manager has approved the alternate methods proposed.
- D. It is the Contractor's responsibility to choose a size of casing at or above the minimum specified, and to ensure that the jacking is done with a high degree of accuracy to permit installation of the carrier pipe to the lines and grades shown on the approved plans.

- E. Steel pipe casings, unless otherwise approved by the Engineering Manager, shall be butt-welded sheets (spiral welding of pipe not allowed) conforming to ASTM A361, ASTM A283, Grade D. Other steel grades may be used upon approval of the Engineering Manager.
- F. Steel pipe casings shall include the installation of an anode in accordance with the Standard Drawings, unless otherwise directed by the Engineering Manager.

2.02 CASING SPACERS

Casing spacers shall be stainless steel, centered-position type with PVC liner and non-metallic anti-friction runners in accordance with the Approved Materials List.

2.03 CASING END SEALS

Casing end seals, in accordance with the Approved Materials List, shall wrap around the casing and carrier pipe to provide a barrier to backfill material and seepage. The casing end seal shall be a minimum 1/4-inch thick styrene butadiene rubber sheet attached to the carrier pipe and casing with 1-inch wide stainless steel bands. Zippered casing end seals with stainless steel bands may also be used.

2.04 WARNING/IDENTIFICATION TAPE

Use marking tape consisting of one layer of aluminum foil laminated between two (2) colored layers of inert plastic film. The lamination bond shall be strong enough that the layers can not be separated by hand. Tape shall be a minimum of 5 mils thick and 6-inches wide. Elongation shall be a minimum of 600%. Tape shall bear a continuous, printed, message every 16 to 36-inches warning of the installation buried below. Tape shall be selected from the Approved Materials List.

PART 3 EXECUTION

3.01 TRENCH EXCAVATION, BACKFILL AND COMPACTION

Trenching, bedding, backfilling and compaction operations shall be performed in accordance with Specification Section 02223.

3.02 JACKING PIT

- A. The approach trench for jacking or boring operations shall be adequately shored to safeguard existing substructures and surface improvements and to ensure against ground movement in the vicinity of the casing portal.
- B. Placement of equipment in the approach trench of the jacking pit shall be firmly bedded on the required line and grade using heavy timbers, structural steel, or concrete cradles of sufficient length to provide accurate control of jacking alignment. Provide space to insert the casing lengths to be jacked. Anchor the timbers and structural steel sections to ensure action of the jacks in line with the axis of the casing. Place a timber or structural steel bearing block between the jacks and the end of the casing to provide uniform bearing upon the casing end evenly distribute the jacking pressure.
- C. After jacking equipment and debris from the tunnel have been removed from the approach trench of jacking pit, prepare the bottom of the jacking pit as a pipe foundation. Remove all

loose and disturbed materials below pipe grade to undisturbed earth and re-compact the material in accordance with Specification Section 02223.

3.03 PIPE CASING INSTALLATION

Installation of pipe casings shall be as described below and in accordance with the Standard Drawings. Only workers experienced in jacking operations shall be used in performing the work of jacking and boring.

- A. The Contractor's attention is called to the fact that extreme care is required in placing the casing so as to permit the installation of the carrier pipe to the lines and grades shown on the Approved Plans.
- B. Gravity flow pipelines are designed at grades that do not permit variance from the lines and grade as shown on the Approved Plans.
- C. Fit a sectional shield or steel jacking head to the leading section of the casing. The shield or head shall extend around the outer surface of the upper two-thirds of the casing and project at least 18-inch beyond the driving end of the casing. It shall not protrude more than 1/2-inch beyond the outer casing surface.
- D. The leading section of casing shall be equipped with a jacking head securely anchored (thereto to prevent any wobble or variation in alignment during the jacking operation).
- E. To avoid loss of ground outside the casing, carry out excavation entirely within the jacking head and not in advance of the head. In general, excavated materials shall be removed from the casing as jacking progresses and no accumulation of excavated material within the casing will be permitted.
- F. A jacking band to reinforce the end of the pipe receiving the jacking thrust will be required.
- G. Control the application of jacking pressure and excavation of material ahead of the advancing casing to prevent it from becoming friction-bound or deviating from required line and grade. Do not encroach upon the minimum annular space detailed. Restrict the excavation of material to the least clearance to prevent binding in order to avoid settlement or possible damage to overlying structures or utilities.
- H. Steel casing sections shall be full-circumference butt-welded in the field. It shall be the Contractors responsibility to provide stress transfer across the joints capable of resisting the jacking forces involved.

3.04 CARRIER PIPE INSTALLATION

- A. Carrier pipe shall be pushed into the casing incorporating the use of casing spacers as described below.
- B. PVC or ductile-iron carrier pipe joints shall be restrained either by mechanical means or by use of splined gaskets.
- C. Steel carrier pipe sections shall be lap joint welded in accordance with Specification Section 15076.

- D. Upstream and downstream elevations of the carrier pipe shall be verified prior to installing the end seals.
- E. The portion of carrier pipe installed within a casing shall have pressure, leakage, and infiltration testing completed in accordance with Specification Sections 15043 and 15044 prior to installation of the end seals.
- F. The annular space between the carrier pipe and casing shall not be filled with any material unless otherwise noted on the Approved Plans.

3.05 CASING SPACERS

Casing spacers shall be used to prevent the carrier pipe bell from touching the casing and to maintain a uniform space between the carrier pipe and casing interior. Casing spacers shall be installed on the carrier pipe at intervals per the manufacturer's recommendations with a minimum of three (3) spacers per pipe section equally spaced.

3.06 CASING END SEALS

Casing end seals shall be installed in accordance with the manufacturer's recommendations. Carrier pipe shall pass hydrostatic or leakage tests in accordance with Specification Sections 15043 or 15044 prior to the installation of casing end seals or backfilling operations.

END OF SECTION 15130

SECTION 15150

WATER METERS

PART 1 GENERAL

1.01 DESCRIPTION

This section describes the purchase, materials, installation and testing of meter assemblies.

1.02 REFERENCE STANDARDS

AWWA C700	Cold Water Meters – Displacement Type, Bronze Main Case
AWWA C701	Cold Water Meters – Turbine Type, for Customer Service
AWWA C702	Cold Water Meters – Compound Type
AWWA C703	Cold Water Meters – Fire Service Type

1.03 RELATED WORK SPECIFIED ELSEWHERE

RMWD	Standard Drawings
Section 02223	Trenching, Backfilling and Compaction
Section 03300	Cast-in-Place Concrete
Section 09900	Painting and Coating
Section 15057	Copper Tubing, Brass, and Bronze Pipe, Fittings
Section 15056	Ductile-Iron Pipe and Fittings
Section 15100	Valves

1.04 APPROVED MANUFACTURERS

All meters shall be supplied by the District.

1.05 WATER METERS

- A. All service runs, meter boxes and other appurtenances shall be furnished and installed by the developer/customer. Meters shall be furnished and installed by the District. Connection fees will be in accordance with governing District ordinance(s). All water services shall be constructed in accordance with the District current Standard Drawings, applicable to the size, type and intended service of the installed water service.
- B. The developer/customer shall conduct a pre-construction conference with the Engineering Manager prior to commencement of water service construction and shall pay all applicable fees and obtain written approval for water service construction in accordance with current District ordinance(s) prior to commencement of construction. Failure to obtain written approval to construct shall constitute a breach of District protocol and may result in the inability of the District to provide water.
- C. The developer/customer shall deposit an amount with the District for inspection of the entire water service installation prior to commencement of work. **No water service(s) shall be constructed or placed into service without District inspection.** All components of the water service installation shall meet the current District standards and the requirements of these specifications. Failure to pay inspection fees or obtain proper District inspection will result in the District inability to provide water supply to all un-inspected water service installations.

- D. The developer and/or customer are responsible for coordinating inspection services through the District for all water service installations. The developer and/or customer shall notify the District Inspector a minimum of five (5) working days prior to starting work; and two (2) working days during the construction for inspections. Failure to provide the sufficient notice to the District Inspector to obtain inspection services may lead to project delays for which the District will not be responsible. Water services installed without proper District inspection shall be uncovered, removed and reinstalled with proper inspection by the developer and/or customer at the developer and/or customer's expense. **No exception will be made to the requirement for District inspection services.**
- E. The developer and/or customer is responsible for the installation of all water service components (except the meter) in accordance with District standards, including but not limited to the couplings, customer service valve and RP device (as appropriate).
- F. Prior to occupancy, the Engineering Manager will, upon finding the installation to be acceptable, record all meter account information and padlock the service stop in the off position.
- G. Subsequent applications for permanent service shall be made in accordance with the District's Rules and Regulations.

1.06 BY-PASS LINE

- A. A by-pass line shall be installed on all meter assemblies 3-inch and larger (see Standard Drawing W-2). A by-pass line is not required under the following conditions, as determined by the Engineering Manager:
 - 1. When the facility is serviced by multiple metered connections; and
 - 2. On agricultural or irrigation services.
- B. A lockable corporation stop or valve shall be installed in all by-pass lines.
- C. A by-pass line may be required on smaller installations that require continuous service, as determined by the Engineering Manager.

PART 2 MATERIALS

2.01 SYNTHETIC METER BOXES

Synthetic meter boxes shall be black in color and shall be manufactured by Carson or approved equal. Sizing of the meter box shall be determined by the current District standard for the sizing of the meter installation.

2.02 COPPER, BRASS, AND BRONZE PIPE, FITTINGS, AND APPURTENANCES

All service connection, by-pass piping, and appurtenances necessary for proper installation of the water service and meter shall conform to Specification Section 15057 and the Standard Drawings.

2.03 DUCTILE-IRON PIPE AND FITTINGS

All piping for meter assemblies 3-inch and larger shall be ductile iron conforming to the requirements of Specification Section 15056.

2.04 MANUAL VALVES

All manual valves shall conform to the requirements of Specification Section 15100. All manual valves shall be lockable in the closed position. On 4-inch and larger by-pass lines, valves with a chain and lock may be permitted.

PART 3 EXECUTION

3.01 METER INSTALLATION

- A. All meters will be set by the District. The developer/customer is responsible for installing all remaining parts per the Standard Drawings.
- B. All meter installations shall conform to the Standard Drawings.

3.02 METER PROTECTION

- A. Reduced Pressure back flow device shall be installed in accordance with District Ordinance conforming to the Standard Drawings. The Cross Connection Control Specialist will determine the degree of hazard and will require the appropriate device.
- B. All meter installations where the maximum static pressure exceeds 150 psi shall include the installation of a pressure regulator on the customer side after the meter and will be the customer's responsibility. Pressure regulators shall be manufactured by Wilkins or approved equal.

3.03 EXCAVATION AND BACKFILL

Excavation and backfill for the meter installation shall be in accordance with Specification Section 02223.

3.04 SERVICE PIPING

- A. All piping for service lines and by-pass lines up to 2-inch shall be installed in conformance with Specification Section 15057.
- B. The piping for all service installations 3-inch and larger shall be in accordance with Specification Section 15056 and the applicable Standard Drawings.
- C. All buried piping for service laterals shall be wrapped with 10 mil tape or sleeved in polyethylene.
- D. Hot taps required for service lateral installations shall be coordinated with the Engineering Manager and shall not be constructed until appropriate District fees have been paid and inspection services have been scheduled. **NO UNAUTHORIZED HOT TAPPING OF DISTRICT PIPELINES IS ALLOWED WITHOUT PRIOR WRITTEN APPROVAL AND AUTHORIZATION BY THE ENGINEERING MANAGER.** Hot taps shall be constructed and installed in accordance with current the RMWD Standards Manual.

3.05 METER VAULT

- A. All meter vaults shall be installed in accordance with current the RMWD Standards Manual. Synthetic meter boxes shall be black in color as manufactured by Carson or approved equal.
- B. Meter boxes shall be furnished and installed by the developer/customer, unless otherwise noted. Sizes shall be as specified on the standard drawings for the various sizes and types of services. Any meter boxes to be requested for review as an equal must have identical lid, color, and inside box dimensions.
- C. Meter boxes shall be set true to line and to the grade of the top of the curb, sidewalk, or surrounding graded area. Meters within 5-feet from a tree shall be in a concrete box.
- D. Meter boxes are not to be set until fine grading or landscape grading has been completed by the developer/customer.

3.06 CONCRETE WORK

All thrust blocks, foundations, and supports shall be of the sizes shown in the applicable standard drawings and conform to Specification Section 03300.

3.07 VALVES

All valves installed shall conform to the requirements of Specification Section 15100.

3.08 PAINTING AND COATING

- A. All exposed and/or buried piping shall be painted or coated in accordance with Specification Section 09900.
- B. The meter lids on all non-potable water services shall be painted in accordance with Specification Section 09900.

3.09 TESTING

All meter services shall be hydrostatically pressure tested during the testing of pipeline in accordance with Specification Section 15044.

END OF SECTION 15150

POTABLE WATER FACILITIES

DRAWINGS

MATERIAL LIST

- ① FORGED STEEL HALF-COUPLING, THREADED, CLASS 3000 WELDED TO PIPE PER W-5. (CML&C PIPE) OR DOUBLE STRAP, STAINLESS STEEL, TAPPING COLLAR (PVC OR DUCTILE IRON)
- ② BRASS CORP STOP
- ③ BRASS MALE/COPPER ADAPTER
- ④ TYPE "K" COPPER TUBING
- ⑤ 45° COPPER ELL
- ⑥ BRASS SERVICE STOP, B-11 W INSTALLED FOR LEFT HAND OPERATION PER RMWD SPEC. 15057 2.03
- ⑦ BRASS METER TAILS WITH GASKETS
- ⑧ WATER METER SUPPLIED BY DISTRICT
- ⑨ BRASS BALL VALVE
- ⑩ HDPE PLASTIC METER BOX AND COVER. FOR 1" USE 20"X26" BOX (BLACK) FOR 1.5" & 2" USE 26"X39" BOX (BLACK). FOR DOUBLE CHECK USE 2 METER BOXES OR ONE LARGE
- ⑪ STATE APPROVED REDUCED PRESSURE BACKFLOW PREVENTION DEVICE
- ⑫ BRONZE BALL VALVE, CLASS 125.
- ⑬ 6" BASE OF 3/4" ROCK
- ⑭ 90° METALLIC ELBOW (COPPER OR BRASS)
- ⑮ BRASS UNION
- ⑯ METALLIC PIPE (COPPER OR BRASS)
- ⑰ SACRIFICIAL ANODE REFER TO CP-16

TYPICAL CONSTRUCTION NOTES:

1. USE SILVER SOLDER FOR COPPER PIPE JOINTS.
2. MORTAR COUPLING AND MALE THREADS OF CORP STOP AFTER CONNECTING TO A MORTAR - COATED STEEL PIPE.
3. APPLY BITUMASTIC COMPOUND TO COUPLING AND MALE THREADS OF CORP STOP AFTER CONNECTING TO A TAR / WRAPPED STEEL PIPE.
4. PIPE THREADS SHALL BE CLEAN, SHARP, AND WRAPPED WITH A PIPE THREAD SEAL TAPE.
5. WHERE METER BOX IS LOCATED IN CONCRETE OR ASPHALT TRAFFIC AREAS, CONTACT DISTRICT FOR AN APPROVED CONCRETE METER BOX.
6. ON 1-1/2" & 2" METERS (WHICH ARE FLANGED), PROVIDE THREADED COMPANION FLANGES, 150-LB.
7. ALL BRASS FITTINGS TO BE DOMESTIC PRODUCTS.
8. WRAP BURIED COPPER WITH 10 MIL CALPICO TAPE OR POLYETHYLENE ENCASMENT.
9. METER TO BACKFLOW - ANY DISTANCE GREATER THAN 3' NEEDS APPROVAL FROM ENGINEER
10. AS APPROVED BY DISTRICT, DOUBLE CHECK TO BE INSTALLED BELLOW GRADE IN METER BOX.

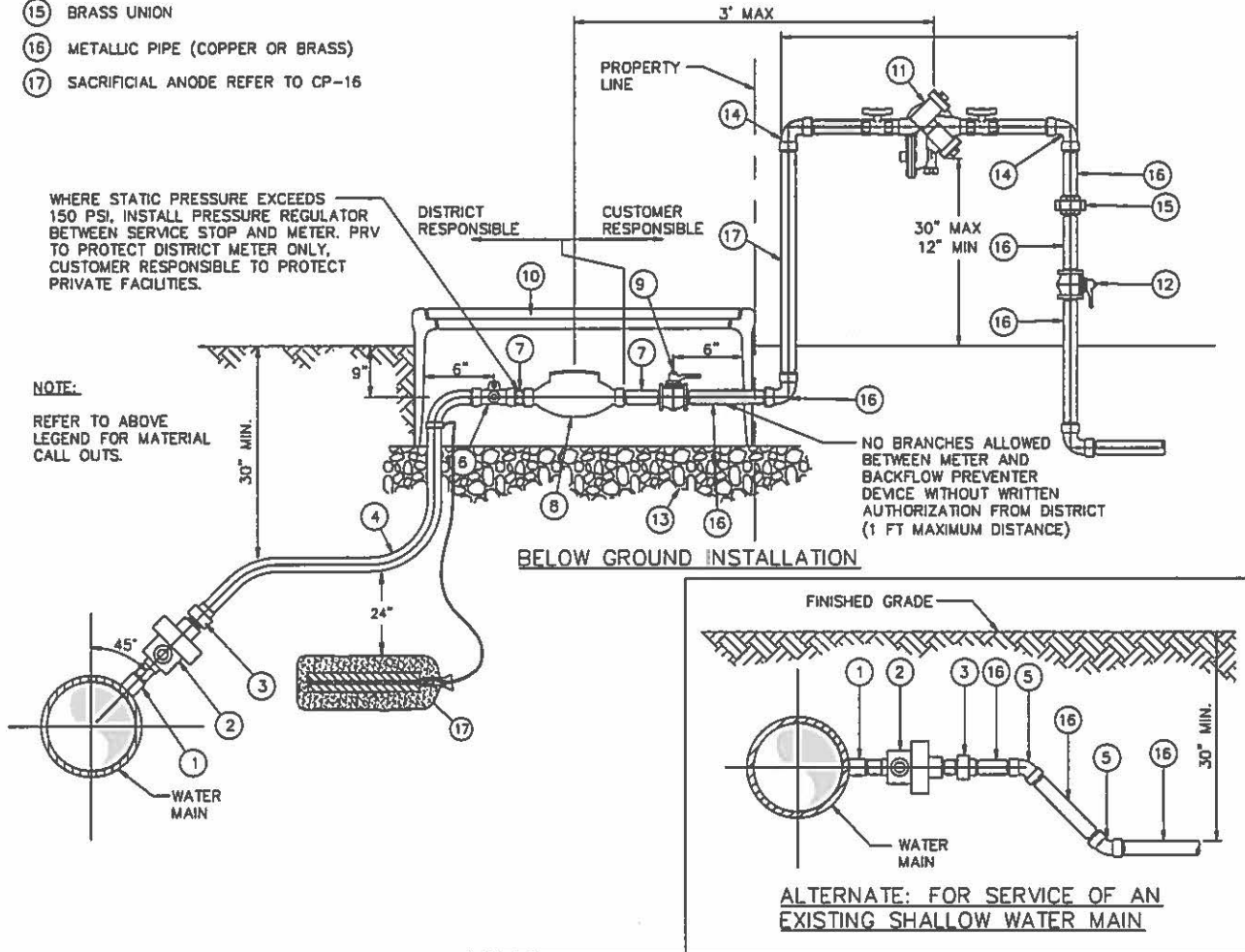

 RAINBOW MUNICIPAL WATER DISTRICT		
APPROVED: <i>Sheryl Blackwell</i> RCE # 79790 EXP.09/30/2016 REVISION APPROVED DATE	TYPICAL 1" TO 2" WATER SERVICE INSTALLATION	STANDARD DRAWING NO. W-1 JULY 2016

MATERIAL LIST

- ① FORGED STEEL HALF-COUPLING, THREADED, CLASS 3000 WELDED TO PIPE PER W-5. (CML&C PIPE) OR DOUBLE STRAP, STAINLESS STEEL, TAPPING COLLAR (PVC OR DUCTILE IRON)
- ② BRASS CORP STOP
- ③ BRASS MALE/COPPER ADAPTER
- ④ TYPE "K" COPPER TUBING
- ⑤ 45° COPPER ELL
- ⑥ BRASS SERVICE STOP, B-11 W INSTALLED FOR LEFT HAND OPERATION PER RMWD SPEC. 15057 2.03
- ⑦ BRASS METER TAILS WITH GASKETS
- ⑧ WATER METER SUPPLIED BY DISTRICT
- ⑨ BRASS BALL VALVE
- ⑩ HDPE PLASTIC METER BOX AND COVER, FOR 1" USE 20"X26" BOX (BLACK) FOR 1.5" & 2" USE 26"X39" BOX (BLACK). FOR DOUBLE CHECK USE 2 METER BOXES OR ONE LARGE
- ⑪ STATE APPROVED REDUCED PRESSURE BACKFLOW PREVENTION DEVICE
- ⑫ BRONZE BALL VALVE, CLASS 125.
- ⑬ 6" BASE OF 3/4" ROCK
- ⑭ 90° METALLIC ELBOW (COPPER OR BRASS)
- ⑮ BRASS UNION
- ⑯ METALLIC PIPE (COPPER OR BRASS)
- ⑰ SACRIFICIAL ANODE REFER TO CP-16
- ⑱ REDUCER BUSHING

TYPICAL CONSTRUCTION NOTES:

- 1. USE SILVER SOLDER FOR COPPER PIPE JOINTS.
- 2. MORTAR COUPLING AND MALE THREADS OF CORP STOP AFTER CONNECTING TO A MORTAR - COATED STEEL PIPE.
- 3. APPLY BITUMASTIC COMPOUND TO COUPLING AND MALE THREADS OF CORP STOP AFTER CONNECTING TO A TAR / WRAPPED STEEL PIPE.
- 4. PIPE THREADS SHALL BE CLEAN, SHARP, AND WRAPPED WITH A PIPE THREAD SEAL TAPE.
- 5. WHERE METER BOX IS LOCATED IN CONCRETE OR ASPHALT TRAFFIC AREAS, CONTACT DISTRICT FOR AN APPROVED CONCRETE METER BOX.
- 6. ON 1-1/2" & 2" METERS (WHICH ARE FLANGED), PROVIDE THREADED COMPANION FLANGES, 150-LB.
- 7. ALL BRASS FITTINGS TO BE DOMESTIC PRODUCTS.
- 8. WRAP BURIED COPPER WITH 10 MIL CALPICO TAPE OR POLYETHALENE ENCASEMENT.
- 9. METER TO BACKFLOW - ANY DISTANCE GREATER THAN 3' NEEDS APPROVAL FROM ENGINEER
- 10. AS APPROVED BY DISTRICT, DOUBLE CHECK TO BE INSTALLED BELLOW GRADE IN METER BOX.

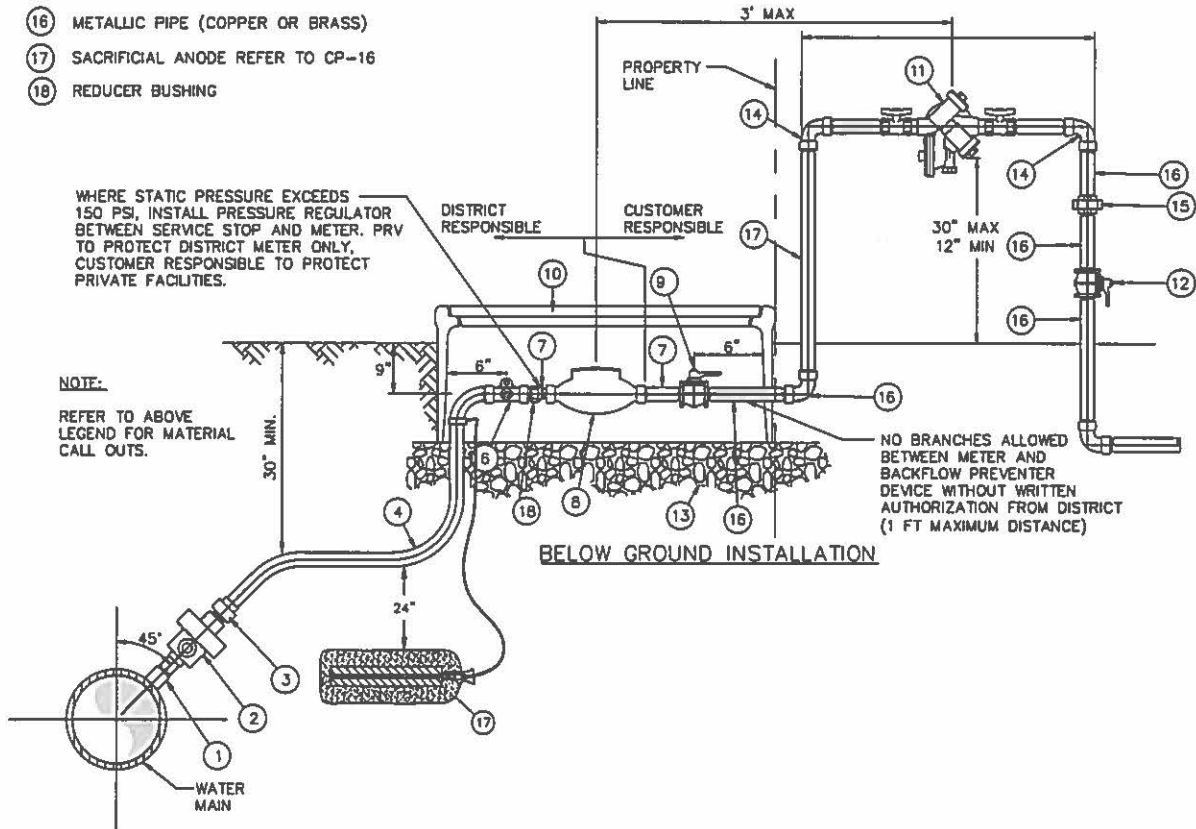

RAINBOW MUNICIPAL WATER DISTRICT

APPROVED: *Shay Pinkstiel*

RCE # 79790 EXP.09/30/2016

REVISION	APPROVED	DATE

**REDUCED
WATER SERVICE INSTALLATION**

STANDARD DRAWING NO.
W-1A
JULY 2016

MATERIAL LIST

- | | |
|---|---|
| <ul style="list-style-type: none"> ① 6" FLANGED OUTLET PER AWWA AND DISTRICT STANDARDS ② 6" FLANGED GATE VALVE, (OR FLANGED PLUG VALVE, WHERE PRESSURE IS GREATER THAN 250 PSI) ③ 3" DI PIPE T.2E. ④ 3"x90° DI PIPE ELBOW, FLANGED. ⑤ VALVE BOX INSTALLATION PER DISTRICT STD. DWG NO. W-19 ⑥ 3" FLANGE X GROVE END SPOOL. ⑦ 3" COUPLING, 150-LB, GALVANIZED. ⑧ WRAP WITH FOAM TAPE FOR CONCRETE PENETRATION ⑨ 3" GATE VALVE, FLANGED, ⑩ PRESSURE GAUGE INSTALLATION PER D.E. ⑪ 3" COMPANION FLANGE, FLANGED, 150-LB (OR 300-LB WHERE PRESSURE IS GREATER THAN 150 PSI) ⑫ WATER METER SUPPLIED BY DISTRICT ⑬ DISTRICT APPROVED REDUCED PRESSURE BACKFLOW PREVENTION DEVICE AS REQUIRED BY THE DISTRICT | <ul style="list-style-type: none"> ⑭ ADJUSTABLE STAINLESS STEEL PIPE SUPPORT FOR 3" PIPING. ⑮ CONCRETE SLAB, CLASS 520-A-2500. ⑯ BACKFILL WITH AGGREGATE BASE, (95% RELATIVE COMPACTION). ⑰ STEEL REBAR, 12" O.C. EACH WAY GRADE 60 #4, AT MID-DEPTH ⑱ THRUST BLOCK, PER RMWD SEC. 03300 ⑲ WRAP PER DISTRICT STANDARDS ⑳ VALVE SUPPORT BLOCK PER STD DWG W-4 ㉑ 6"x3" DI PIPE REDUCER, FLANGED ㉒ WHERE STATIC PRESSURE EXCEEDS 150 PSI, INSTALL PRESSURE REDUCING VALVE BETWEEN ISOLATION VALVE AND METER. PROVIDE SUFFICIENT CLEARANCE BEFORE METER ACCORDING TO MANUFACTURER SPECIFICATIONS. ㉓ PROVIDE SUFFICIENT CLEARANCE UPSTREAM AND DOWNSTREAM OF METER ACCORDING TO MANUFACTURER SPECIFICATIONS. |
|---|---|

NOTES:

1. CUSTOMER RESPONSIBLE FOR SUPPLYING PRESSURE REDUCING VALVE (PRV) WHEN PRESSURE EXCEEDS 175 PSI. REFER TO THE UNIFORM BUILDING CODE AND A PRIVATE ENGINEER REGARDING INSTALLATION OF A PRV AFTER THE METER.

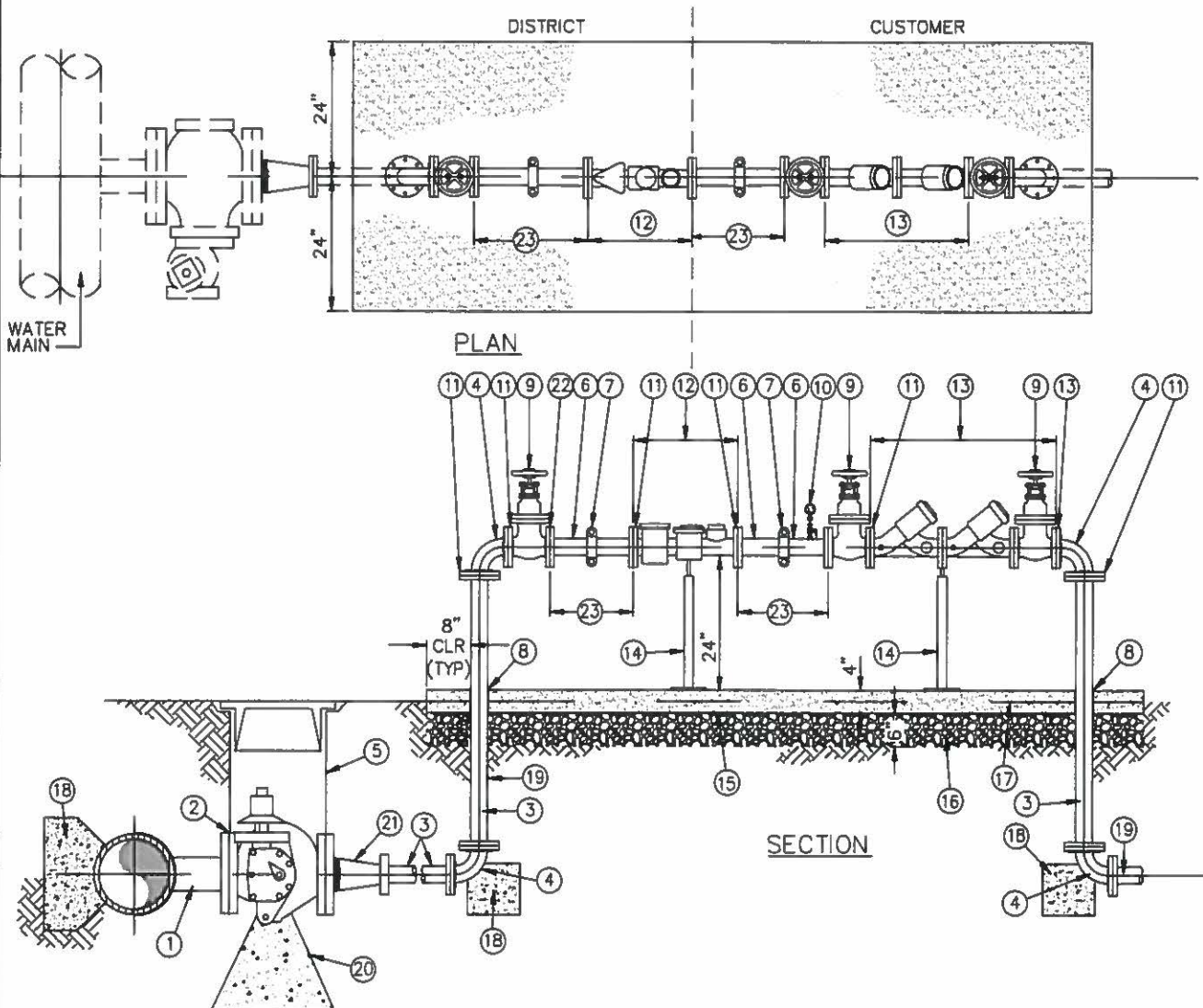

RAINBOW MUNICIPAL WATER DISTRICT

APPROVED: *Jean Stokstad*

RCE # 79790 EXP.09/30/2016

REVISION	APPROVED	DATE

3" WATER SERVICE

STANDARD DRAWING NO.
W-2
JULY 2016

MATERIAL LIST

- | | |
|--|---|
| <ul style="list-style-type: none"> ① 6" FLANGED OUTLET PER AWWA AND DISTRICT STANDARDS ② 6" FLANGED GATE VALVE, (OR FLANGED PLUG VALVE, WHERE PRESSURE IS GREATER THAN 250 PSI) ③ DI PIPE T.2E. ④ 90° DI PIPE ELBOW, FLANGED. ⑤ VALVE BOX INSTALLATION PER DISTRICT STD. DWG NO. W-19 ⑥ FLANGE X GROVE END SPOOL. ⑦ COUPLING, 150-LB, GALVANIZED. ⑧ WRAP WITH FOAM TAPE FOR CONCRETE PENETRATION ⑨ FLANGED GATE VALVE (OR FLANGED PLUG VALVE, WHERE PRESSURE IS GREATER THAN 250 PSI), WITH HANDWHEEL OPERATOR ⑩ PRESSURE GAUGE INSTALLATION PER D.E. ⑪ COMPANION FLANGE, FLANGED, 150-LB ⑫ WATER METER SUPPLIED BY DISTRICT | <ul style="list-style-type: none"> ⑬ DISTRICT APPROVED REDUCED PRESSURE BACKFLOW PREVENTION DEVICE AS REQUIRED BY THE DISTRICT ⑭ ADJUSTABLE STAINLESS STEEL PIPE SUPPORT PIPING. ⑮ CONCRETE SLAB, CLASS 520-A-2500. ⑯ BACKFILL WITH AGGREGATE BASE, (95% RELATIVE COMPACTION). ⑰ STEEL REBAR, 12" O.C. EACH WAY GRADE 60 #4, AT MID-DEPTH ⑱ THRUST BLOCK, PER RMWD SEC. 03300 ⑲ WRAP PER DISTRICT STANDARDS ⑳ VALVE SUPPORT BLOCK PER STD DWG W-4 ㉑ BRASS SERVICE STOP, INSTALLED FOR RIGHT HAND OPERATION PER RMWD SPEC. 15057 2.03 ㉒ 2" BRASS PIPE ㉓ BRASS UNION ㉔ 90° BRASS ELBOW ㉕ FORGE STEEL HALF-COUPLING, THREADED, CLASS 3000 DOUBLE STRAP, STAINLESS STEEL, TAPING COLLAR ㉖ BRASS NIPPLE ㉗ INSTALL 6"x4" DI PIPE REDUCER, FLANGED FOR 4" WATER SERVICE. ㉘ PROVIDE SUFFICIENT CLEARANCE UPSTREAM AND DOWNSTREAM OF METER ACCORDING TO MANUFACTURER SPECIFICATIONS. |
|--|---|

NOTES:

1. CUSTOMER RESPONSIBLE FOR SUPPLYING PRESSURE REDUCING VALVE (PRV) WHEN PRESSURE EXCEEDS 175 PSI. REFER TO THE UNIFORM BUILDING CODE AND A PRIVATE ENGINEER REGARDING INSTALLATION OF A PRV AFTER THE METER.
2. REPLACE 150-LB VALVES AND PIPING WITH COMPONENTS TO MEET PRESSURE REQUIREMENTS IN HIGH PRESSURE AREAS

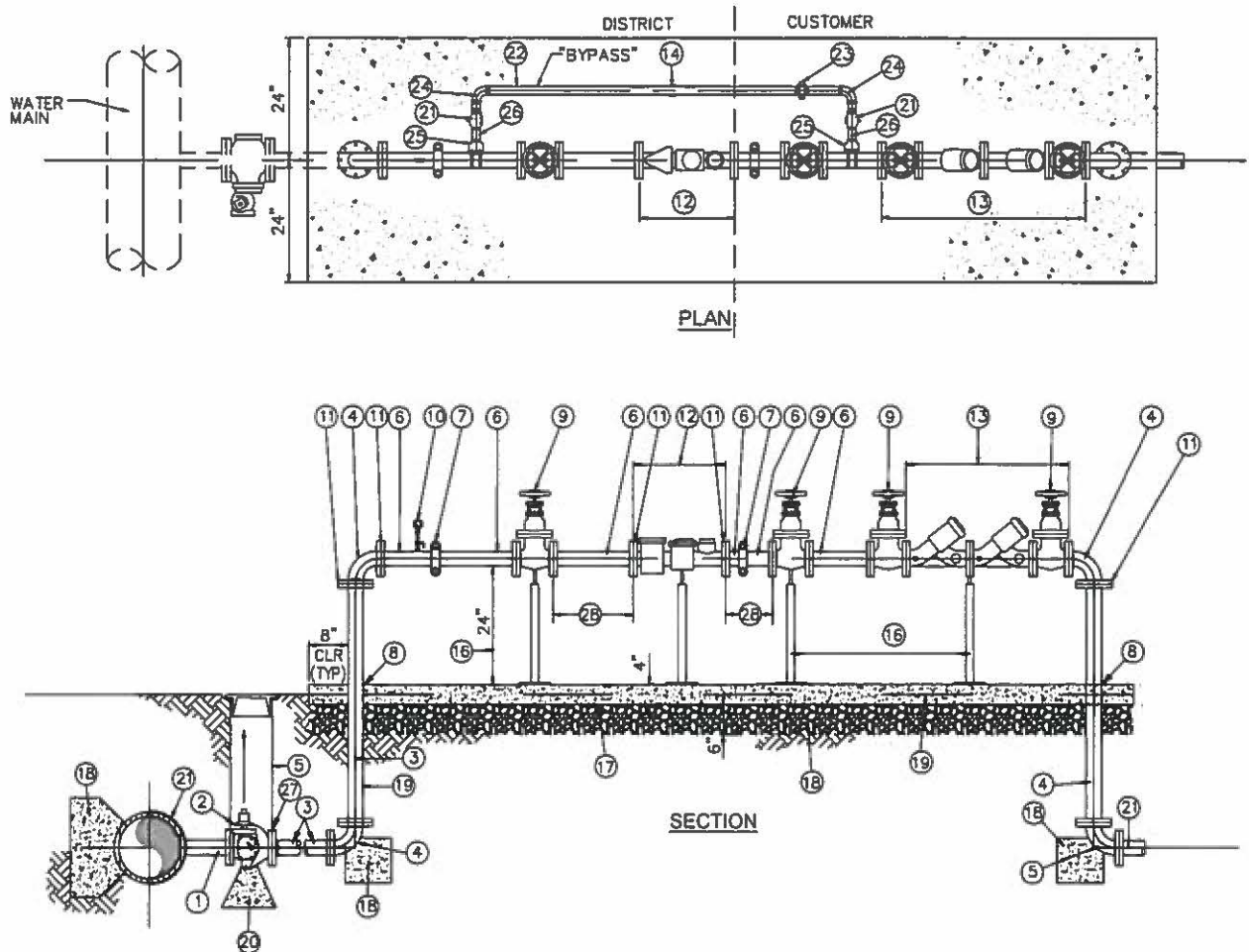

RAINBOW MUNICIPAL WATER DISTRICT

APPROVED: <i>Shirley K. Patrick</i>		
RCE # 79790 EXP.09/30/2016		
REVISION	APPROVED	DATE

4" TO 6" WATER SERVICE

STANDARD DRAWING NO.
W-2A
JULY 2016

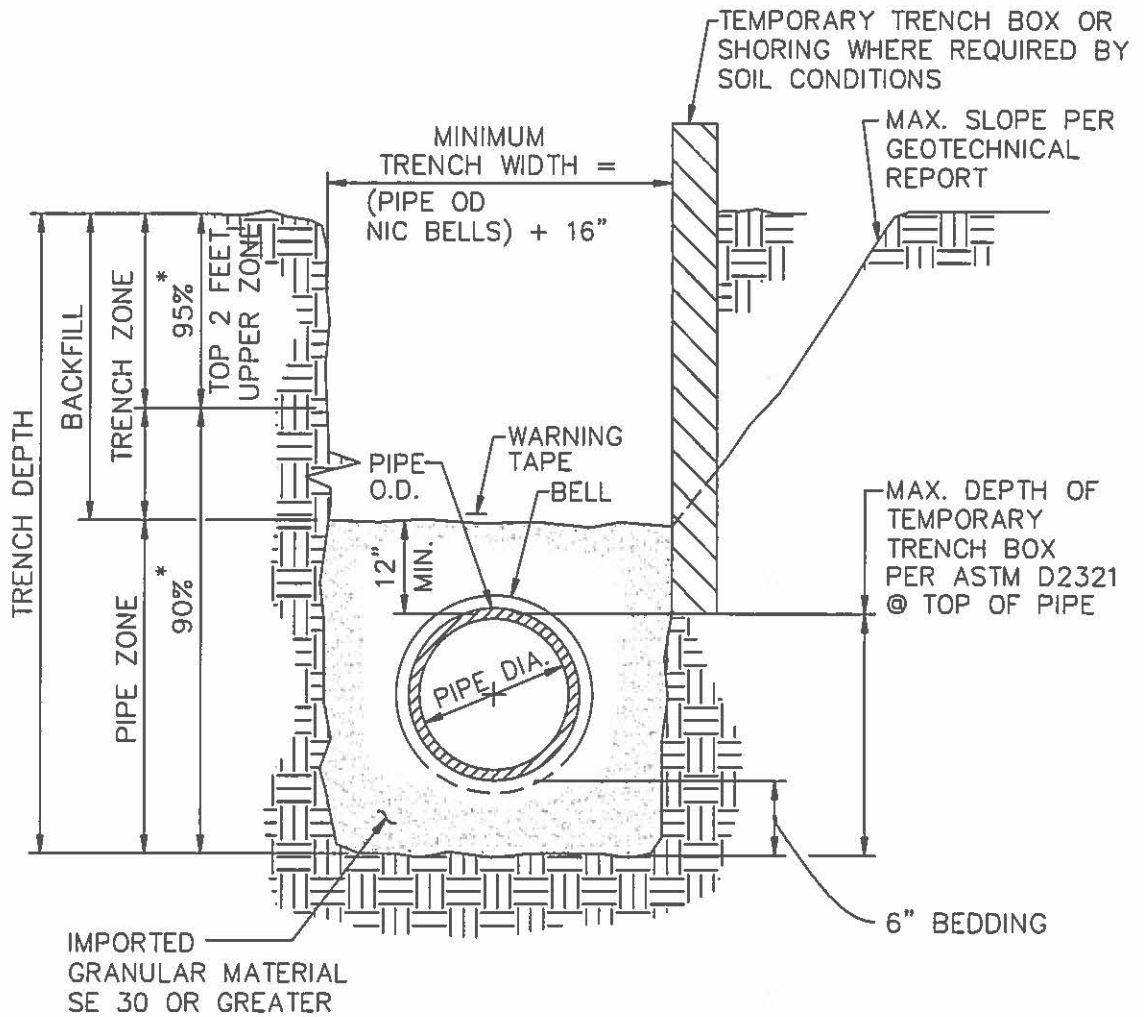

NOTES:

1. REFER TO SECTION 02223 OF THE SPECIFICATIONS
2. PAVING OR PAVEMENT REPAIR TO BE DONE IN ACCORDANCE TO CITY OR COUNTY STANDARDS
3. EXCAVATE BELL HOLES AT EACH PIPE JOINT TO PERMIT PROPER ASSEMBLY AND INSPECTION OF THE ENTIRE JOINT.
4. (*) INDICATES MINIMUM RELATIVE COMPACTION.



RAINBOW MUNICIPAL WATER DISTRICT

APPROVED: <i>Shay P. K... [Signature]</i>		
RCE # 79790 EXP.09/30/2016		
REVISION	APPROVED	DATE

STANDARD PIPE ZONE AND TRENCH BACKFILL

STANDARD DRAWING NO.
W-3
JULY 2016

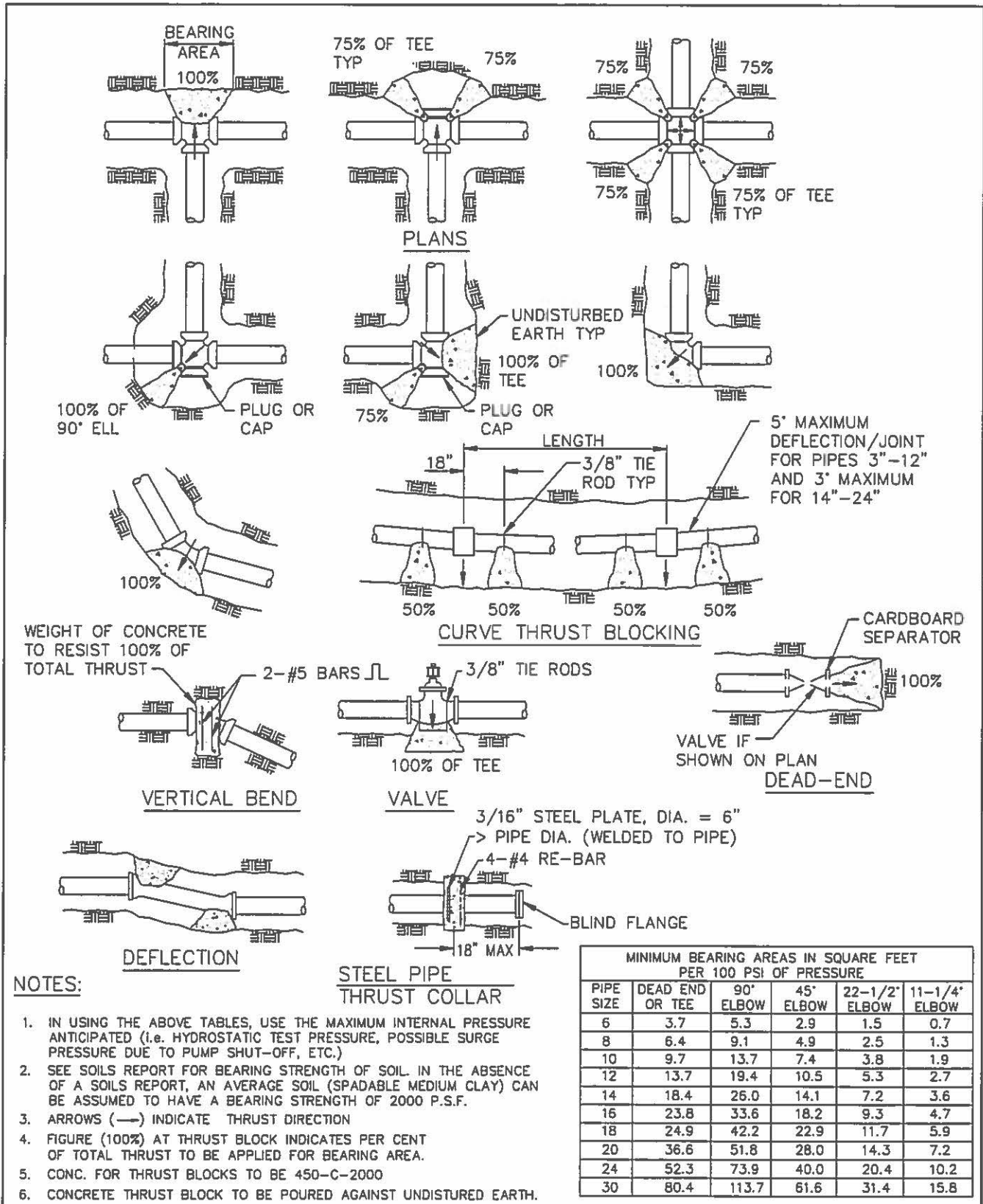

WEIGHT OF CONCRETE TO RESIST 100% OF TOTAL THRUST

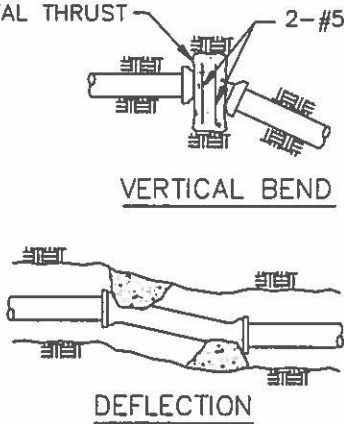

VERTICAL BEND

DEFLECTION

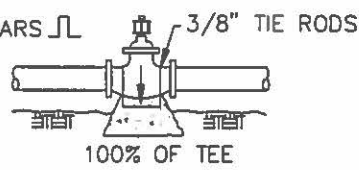

VALVE

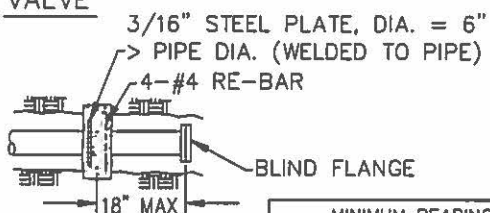

STEEL PIPE THRUST COLLAR

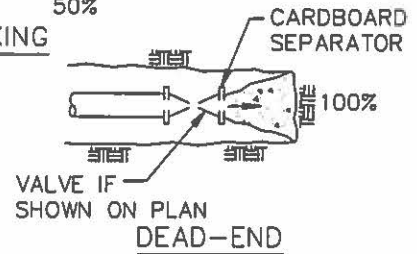

DEAD-END

MINIMUM BEARING AREAS IN SQUARE FEET PER 100 PSI OF PRESSURE					
PIPE SIZE	DEAD END OR TEE	90° ELBOW	45° ELBOW	22-1/2° ELBOW	11-1/4° ELBOW
6	3.7	5.3	2.9	1.5	0.7
8	6.4	9.1	4.9	2.5	1.3
10	9.7	13.7	7.4	3.8	1.9
12	13.7	19.4	10.5	5.3	2.7
14	18.4	26.0	14.1	7.2	3.6
16	23.8	33.6	18.2	9.3	4.7
18	24.9	42.2	22.9	11.7	5.9
20	36.6	51.8	28.0	14.3	7.2
24	52.3	73.9	40.0	20.4	10.2
30	80.4	113.7	61.6	31.4	15.8

NOTES:

1. IN USING THE ABOVE TABLES, USE THE MAXIMUM INTERNAL PRESSURE ANTICIPATED (i.e. HYDROSTATIC TEST PRESSURE, POSSIBLE SURGE PRESSURE DUE TO PUMP SHUT-OFF, ETC.)
2. SEE SOILS REPORT FOR BEARING STRENGTH OF SOIL IN THE ABSENCE OF A SOILS REPORT, AN AVERAGE SOIL (SPADABLE MEDIUM CLAY) CAN BE ASSUMED TO HAVE A BEARING STRENGTH OF 2000 P.S.F.
3. ARROWS (→) INDICATE THRUST DIRECTION
4. FIGURE (100%) AT THRUST BLOCK INDICATES PER CENT OF TOTAL THRUST TO BE APPLIED FOR BEARING AREA.
5. CONC. FOR THRUST BLOCKS TO BE 450-C-2000
6. CONCRETE THRUST BLOCKS TO BE POURED AGAINST UNDISTURBED EARTH.



RAINBOW MUNICIPAL WATER DISTRICT

APPROVED: *Shafiqul Kabir*

RCE # 79790 EXP.09/30/2016

REVISION	APPROVED	DATE

CONCRETE THRUST BLOCKS

STANDARD DRAWING NO.

W-4

JULY 2016

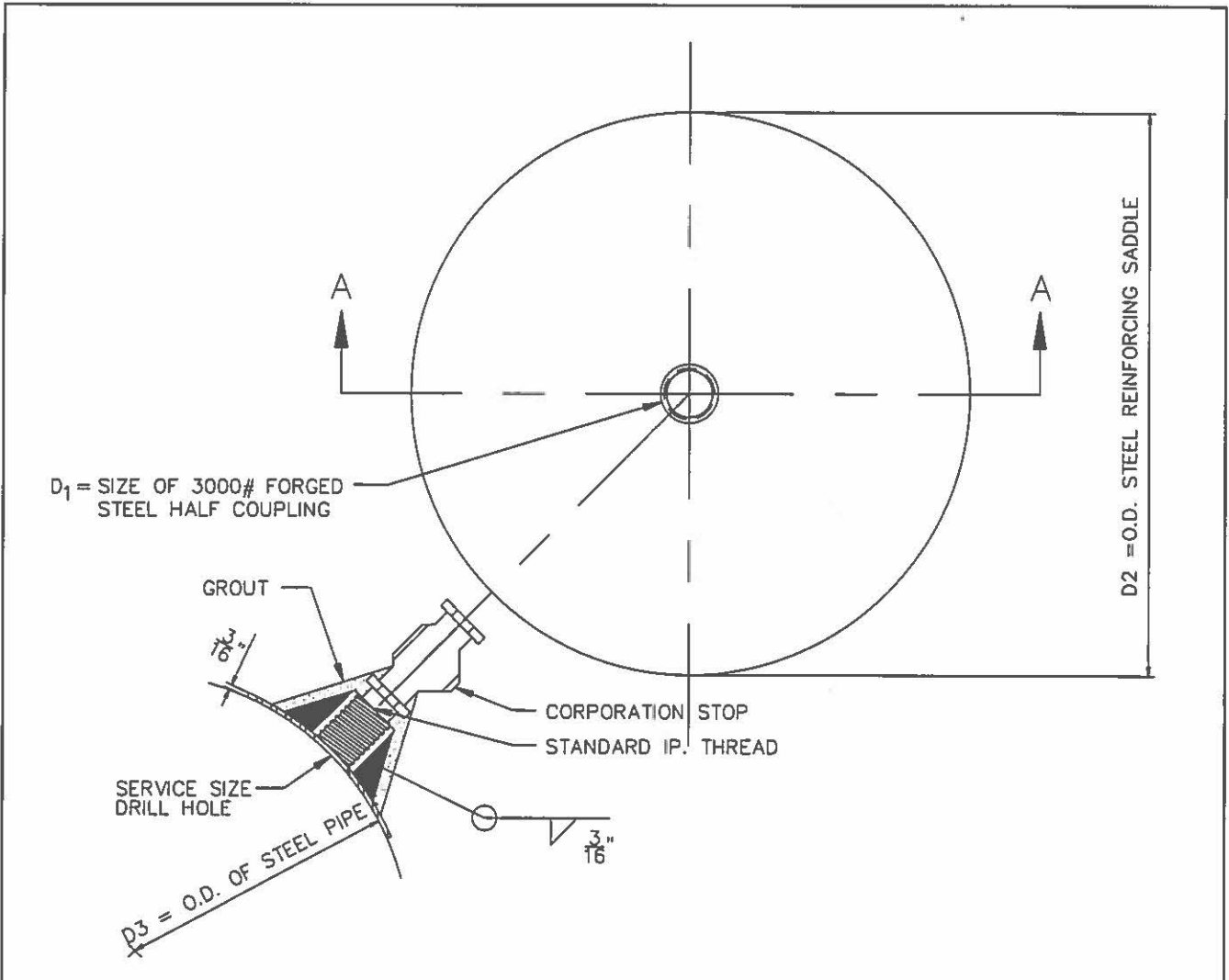

NOTES:

1. USE DOUBLE-PASS WELDS FOR FABRICATION & FIELD WELDS.
2. SADDLE CURVATURE TO BE FORMED TO MEET PIPE DIAMETERS D_3 AS INDICATED.
3. WHEN INSTALLED, OUTLET TO BE COATED WITH SAME COATING AS PIPE.
4. SERVICE LATERALS TO BE INSTALLED AT 45° ANGLE ABOVE SPRINGLINE OF PIPE.

SECTION A-A

SADDLE DIMENSIONS		
SERVICE SIZE	D ₁	D ₂
3/4" / 1"	1 1/4"	5"
1 1/2" / 2"	2 1/2"	7"



RAINBOW MUNICIPAL WATER DISTRICT

APPROVED: <i>Shawn Patrick</i>		
RCE # 79790 EXP.09/30/2016		
REVISION	APPROVED	DATE

SERVICE OUTLET SADDLE

STANDARD DRAWING NO.
W-5
JULY 2016

NOTES:

- 1) BLOWOFF INSTALLED AT STREETS OR ROADS WITHOUT CURBS SHALL BE PROTECTED WITH GUARD POSTS (2) PER RMWD STANDARD DETAIL W-13
- 2) ROLLED CURB OR AC CURBS SHALL HAVE GUARD POSTS (2) PER RMWD STANDARD DETAIL W-13

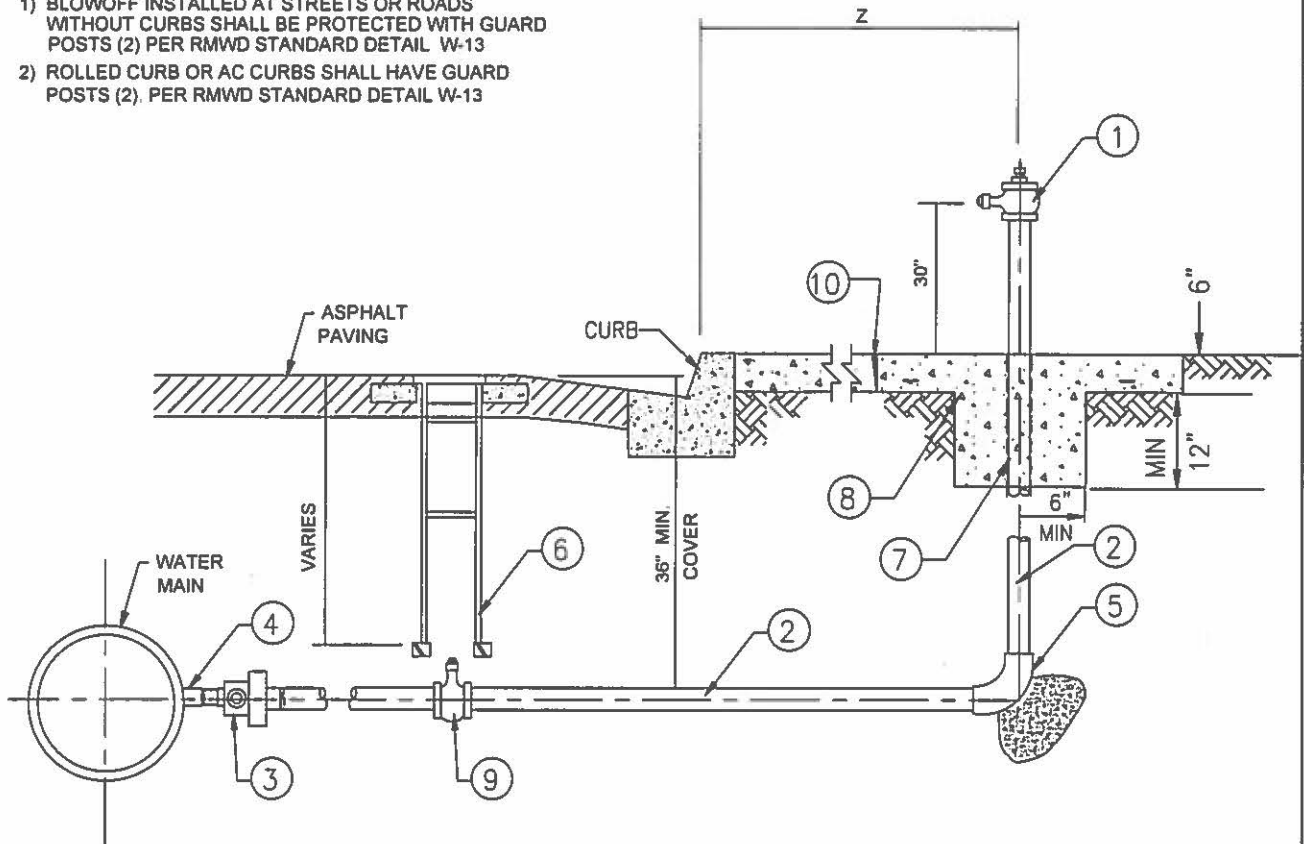

Z 2'- 6" FROM BACK OF SIDEWALK
 2'- 6" FROM FACE OF CURB IF NO SIDEWALK EXISTS.

ITEM	DESCRIPTION	REMARKS
1	2" ANGLE FIRE PLUG VALVE	BRASS
2	2" BRASS PIPE	BRASS
3	BRASS CORPORATION STOP	SEE APPROVED MATERIALS LIST
4	FORGE STEEL HALF-COUPLING, THREADED, CLASS 3000 WELDED TO PIPE. (CMLC PIPE) OR DOUBLE STRAP, STAINLESS STEEL, TAPPING COLLAR (PVC OR DIP)	PER RMWD STD. DWG. W-5
5	90° BRASS ELBOW	
6	VALVE BOX INSTALLATION	PER RMWD STD. DWG. W-19
7	PVC SLEEVE, EXTEND 2" BELOW CONCRETE	
8	2' SQUARE CONCRETE BASE	560-C-3250
9	2" BALL VALVE	
10	1/2" EXPANSION JOINT	



RAINBOW MUNICIPAL WATER DISTRICT

APPROVED:	_____	
RCE # 79790 EXP.09/30/2016		
REVISION	APPROVED	DATE

2" BLOW OFF ASSEMBLY

STANDARD DRAWING NO.
W-6
JULY 2016

NOTES:

- 1) BLOWOFF INSTALLED AT STREETS OR ROADS WITHOUT CURBS SHALL BE PROTECTED WITH GUARD POSTS (2) PER RMWD STANDARD DETAIL W-13
- 2) ROLLED CURB OR AC CURBS SHALL HAVE GUARD POSTS (2). PER RMWD STANDARD DETAIL W-13
- 3) FOR 6" BLOWOFF, USE STANDARD FIRE HYDRANT PER RMWD STD. DETAIL W-9 OR W-10

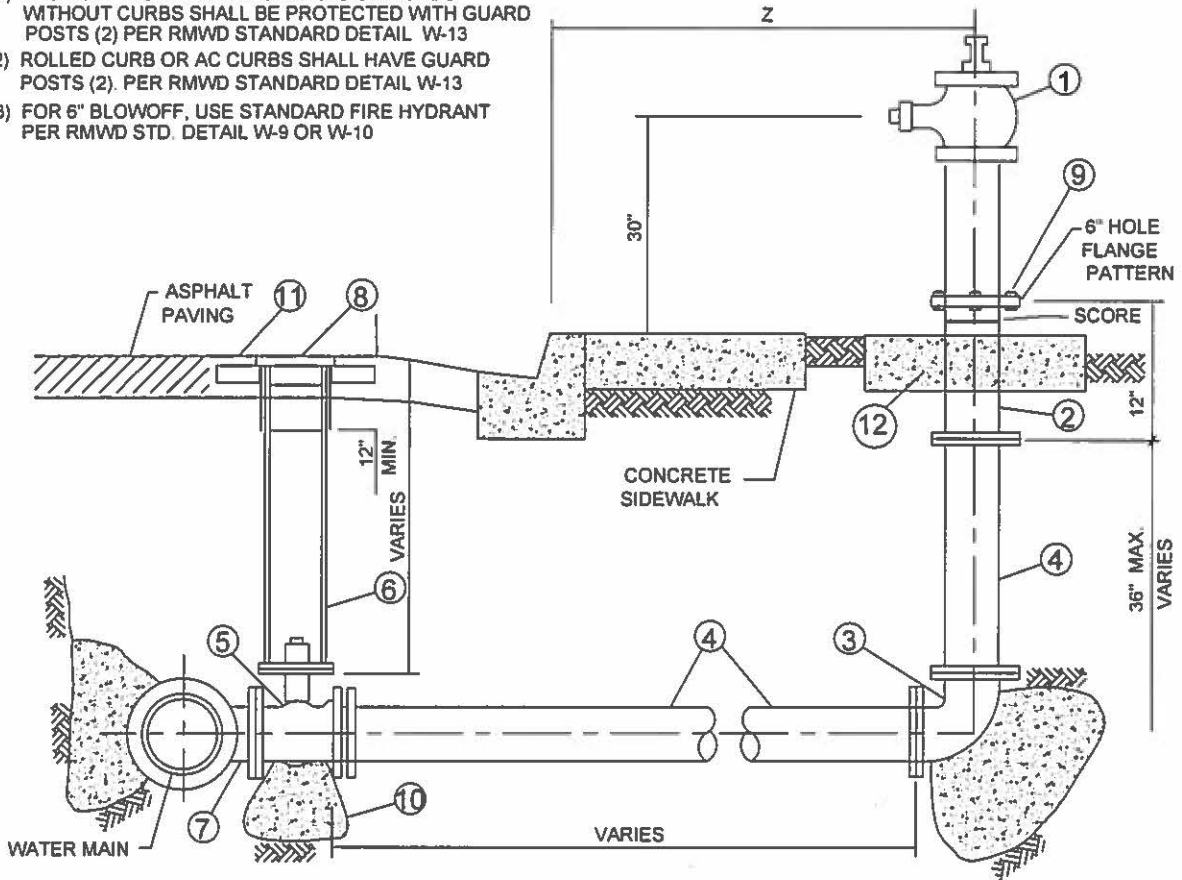

Z 2'-6" FROM BACK OF SIDEWALK
2'-6" FROM FACE OF CURB IF NO SIDEWALK EXISTS.

ITEM	NO.	DESCRIPTION	REMARKS
1	1	4" ANGLE FIRE PLUG VALVE	6 BOLTS, ALL BRONZE, SAFETY YELLOW
2	1	BREAK-OFF RISER, 6" FL. STL OR DI	SCORED (NOT MOLDED)
3	1	4" FL x FL BEND	LENGTH AS REQUIRED FL x FL
4	-	4" FL. STL OR DI PIPE	
5	1	4" GATE VALVE FL x MJ OR FLX TYTON	
6	1	CASING, 8" PVC SDR35 OR C900	
7	1	4" FLANGED OUTLET	
8	1	8" CAST IRON VALVE BOX COVER	
9	6	BREAK-OFF BOLTS, THREADS UP FILL W/ SILICON	
10	-	VALVE SUPPORT	PER SDRSD W-12B, TYPE 1
11	-	CONCRETE RING WITH AC CAP	PER RMWD STD. DETAIL W-4
12		4'X4' CONCRETE PAD, 4" THICK, 520-C-2500	



RAINBOW MUNICIPAL WATER DISTRICT

APPROVED: _____		
RCE # 79790 EXP.09/30/2016		
REVISION	APPROVED	DATE

4" BLOW-OFF ASSEMBLY
(FOR PRESSURE LESS THAN 250 PSI)

STANDARD DRAWING NO.
W-7
JULY 2016

NOTES:

- 1) BLOWOFF INSTALLED AT STREETS OR ROADS WITHOUT CURBS SHALL BE PROTECTED WITH GUARD POSTS (2) PER RMWD STANDARD DETAIL W-13
- 2) ROLLED CURB OR AC CURBS SHALL HAVE GUARD POSTS (2). PER RMWD STANDARD DETAIL W-13
- 3) FOR 6" BLOWOFF, USE STANDARD FIRE HYDRANT PER RMWD STD. DETAIL W-9 OR W-10

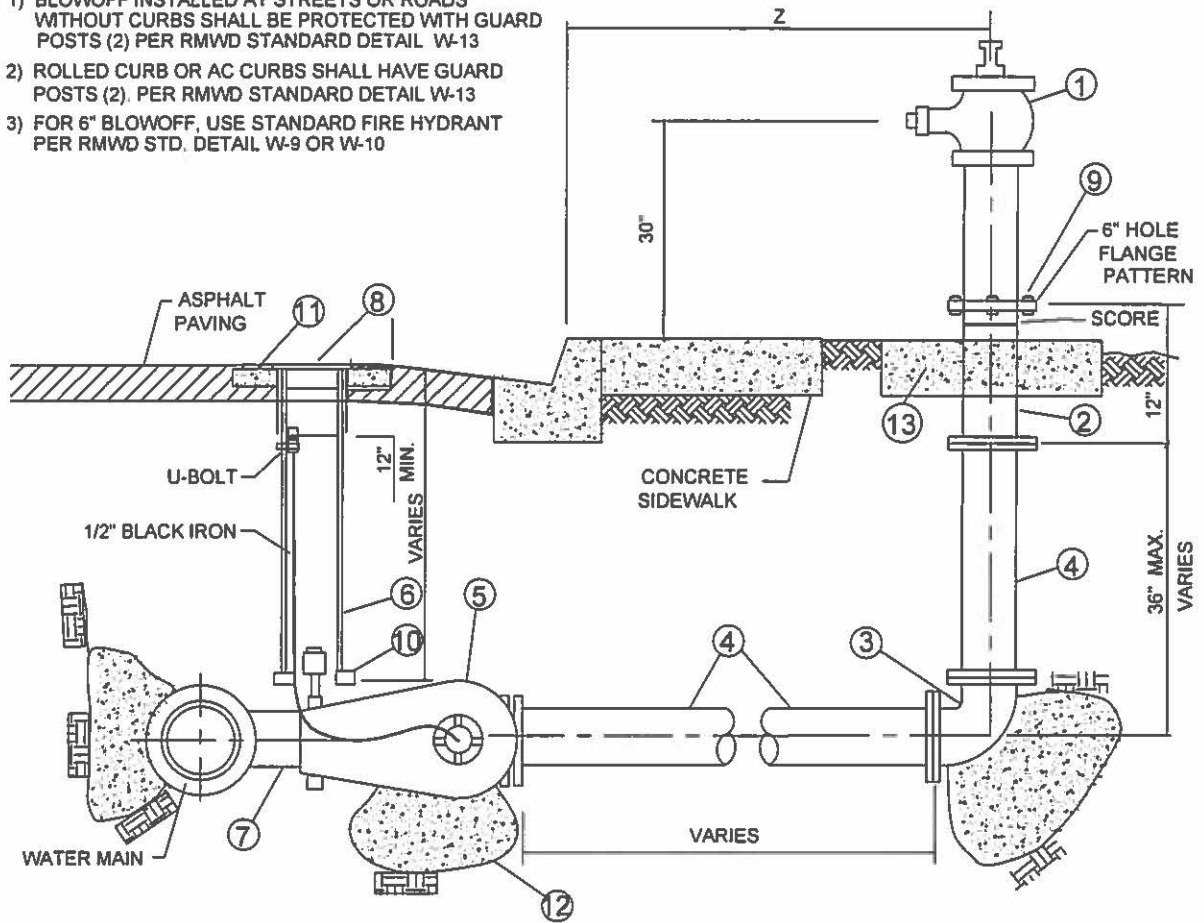

Z 2'-6" FROM BACK OF SIDEWALK
2'-6" FROM FACE OF CURB IF NO SIDEWALK EXISTS.

ITEM	NO.	DESCRIPTION	REMARKS
1	1	4" ANGLE FIRE PLUG VALVE	6 BOLTS, ALL BRONZE, SAFETY YELLOW
2	1	BREAK-OFF RISER, 6" FL. STL OR DI	SCORED (NOT MOLDED)
3	1	4" FL x FL BEND	LENGTH AS REQUIRED FL x FL
4	-	4" FL. STL OR DI PIPE	
5	1	4" FL x FL PLUG VALVE	
6	1	CASING, 8" PVC SDR35 OR C900	
7	1	4" FLANGED OUTLET	
8	1	8" CAST IRON VALVE BOX COVER	
9	6	BREAK-OFF BOLTS, THREADS UP FILL W/ SILICON	300 PSI AND BELOW
10	2	RED BRICK	
11	-	CONCRETE RING WITH AC CAP	PER RMWD STD. DETAIL W-4
12	-	VALVE SUPPORT	PER SDRSD W-12B, TYPE 1
13		4'X4' CONCRETE PAD, 4"THICK, 520-C-2500	



RAINBOW MUNICIPAL WATER DISTRICT

APPROVED: _____

RCE # 79790 EXP.09/30/2016

REVISION	APPROVED	DATE

4" BLOW-OFF ASSEMBLY
(FOR PRESSURE GREATER THAN 250 PSI)

STANDARD DRAWING NO.
W-8
JULY 2016

NOTES:

- 1) FIRE HYDRANTS INSTALLED AT STREETS OR ROADS WITHOUT CURBS SHALL BE PROTECTED WITH GUARD POSTS (2). PER RMWD STANDARD DETAIL W-13
- 2) ROLLED CURB OR AC CURBS SHALL HAVE GUARD POSTS (2). PER RMWD STANDARD DETAIL W-13

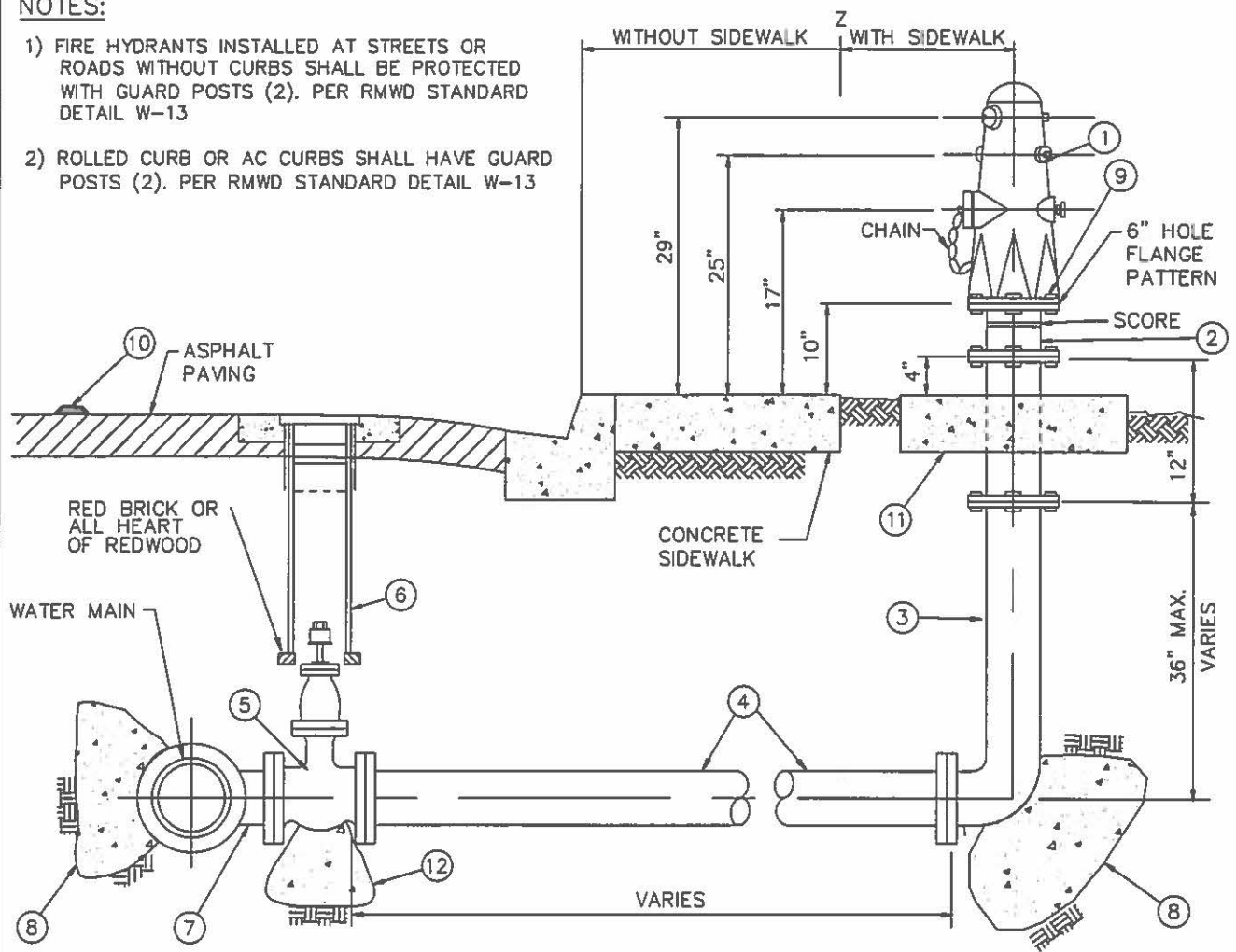

Z 2'-6" FROM BACK OF SIDEWALK.
2'-6" FROM FACE OF CURB IF NO SIDEWALK EXISTS.

DESCRIPTION	BARRELS OUTLETS
COMMERCIAL FIRE HYDRANT	6" x 4" x 2 1/2" x 2 1/2"
SINGLE FAMILY RESIDENTIAL	6" x 4" x 2 1/2"

ITEM NO.	DESCRIPTION	REMARKS
1	6" FIRE HYDRANT	6 BOLTS, ALL BRONZE, SAFETY YELLOW
2	BREAK-OFF RISER, 6" STEEL OR CAST IRON	SCORED (NOT MOLDED)
3	DUCTILE IRON BURY ELL	
4	6" DI PIPE	
5	6" GATE VALVE FL OR PO	PER STANDARD SPECIFICATION
6	VALVE BOX INSTALLATION PER DISTRICT STD. DWG# W-19	SEE STANDARD SPECIFICATION
7	6" FLANGED OUTLET	PER STANDARD SPECIFICATION
8	THRUST BLOCK	PER RMWD 03300
9	BREAK OFF BOLTS, THREADS UP FILL W/SILICON	PER STANDARD SPECIFICATIONS
10	REFLECTIVE PAVEMENT MARKER (BLUE)	PER FIRE DISTRICT REQUIREMENTS
11	4' x 4' CONCRETE PAD, 4" THICK, 520-C-2500	
12	VALVE SUPPORT BLOCK	PER RMWD STD. DETAIL W-4



RAINBOW MUNICIPAL WATER DISTRICT

APPROVED: *Shafiqul Kabir*

RCE # 79790 EXP.09/30/2016

REVISION	APPROVED	DATE

6" FIRE HYDRANT ASSEMBLY
(FOR PRESSURE LESS THAN 250 PSI)

STANDARD DRAWING NO.
W-9
JULY 2016

NOTES:

- 1) FIRE HYDRANTS INSTALLED AT STREETS OR ROADS WITHOUT CURBS SHALL BE PROTECTED WITH GUARD POSTS (2). PER RMWD STANDARD DETAIL W-13
- 2) ROLLED CURB OR AC CURBS SHALL HAVE GUARD POSTS (2). PER RMWD STANDARD DETAIL W-13

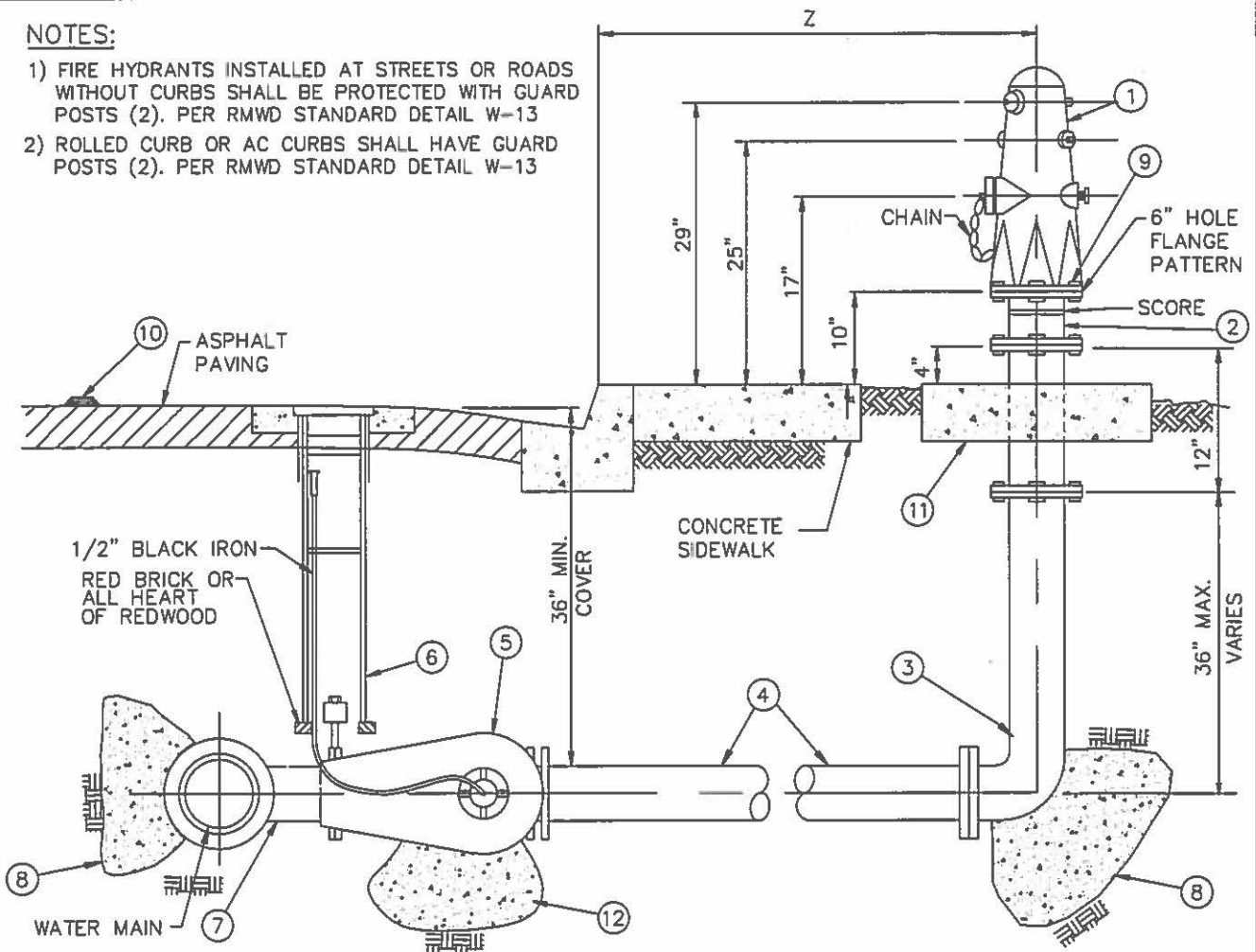

Z 2'-6" FROM BACK OF SIDEWALK.
2'-6" FROM FACE OF CURB IF NO SIDEWALK EXISTS.

DESCRIPTION	BARRELS OUTLETS
COMMERCIAL FIRE HYDRANT	6"x4"x2 1/2"x2 1/2"
SINGLE FAMILY RESIDENTIAL	6"x4"x2 1/2"

ITEM	NO.	DESCRIPTION	REMARKS
1	1	6" FIRE HYDRANT	6 BOLTS, ALL BRONZE, SAFETY YELLOW
2	1	BREAK-OFF RISER, 6" STEEL OR CAST IRON	SCORED (NOT MOLDED)
3	1	DUCTILE IRON BURIED ELL, FLG.	
4	-	6" DI PIPE	CL-300
5	1	6" PLUG VALVE, FLG.	PER STANDARD SPECIFICATION
6	1	VALVE BOX INSTALLATION PER DISTRICT STD. DWG# W-19	SEE STANDARD SPECIFICATION
7	1	6" FLANGED OUTLET	PER STANDARD SPECIFICATION
8	1	THRUST BLOCK	PER RMWD STD. DETAIL W-4
9	6	BREAK OFF BOLTS BELOW 300 psi. FILL W/ SILICONE	PER STANDARD SPECIFICATIONS
10	1	REFLECTIVE PAVEMENT MARKER (BLUE)	PER FIRE DISTRICT REQUIREMENTS
11	1	4' x 4' CONCRETE PAD 4" THICK, 520-C-2500	
12	-	VALVE SUPPORT BLOCK	



RAINBOW MUNICIPAL WATER DISTRICT

APPROVED: *Sheela Patel*

RCE # 79790 EXP.09/30/2016

REVISION	APPROVED	DATE

6" FIRE HYDRANT ASSEMBLY
(FOR PRESSURE GREATER THAN 250 PSI)

STANDARD DRAWING NO.
W-10
JULY 2016

GENERAL NOTES:

- 1) NO DIPS OR LOW SPOTS WILL BE ALLOWED IN PIPING INSTALLATION
- 2) ROLLED CURBS AND AC CURB SHALL HAVE GUARD POSTS (2) PER RMWD STD DETAIL W-13
- 3) COAT THREADS WITH ANTI-SIEZE
- 3) AIR VAC ASSEMBLY MUST MEET PRESSURE RATING

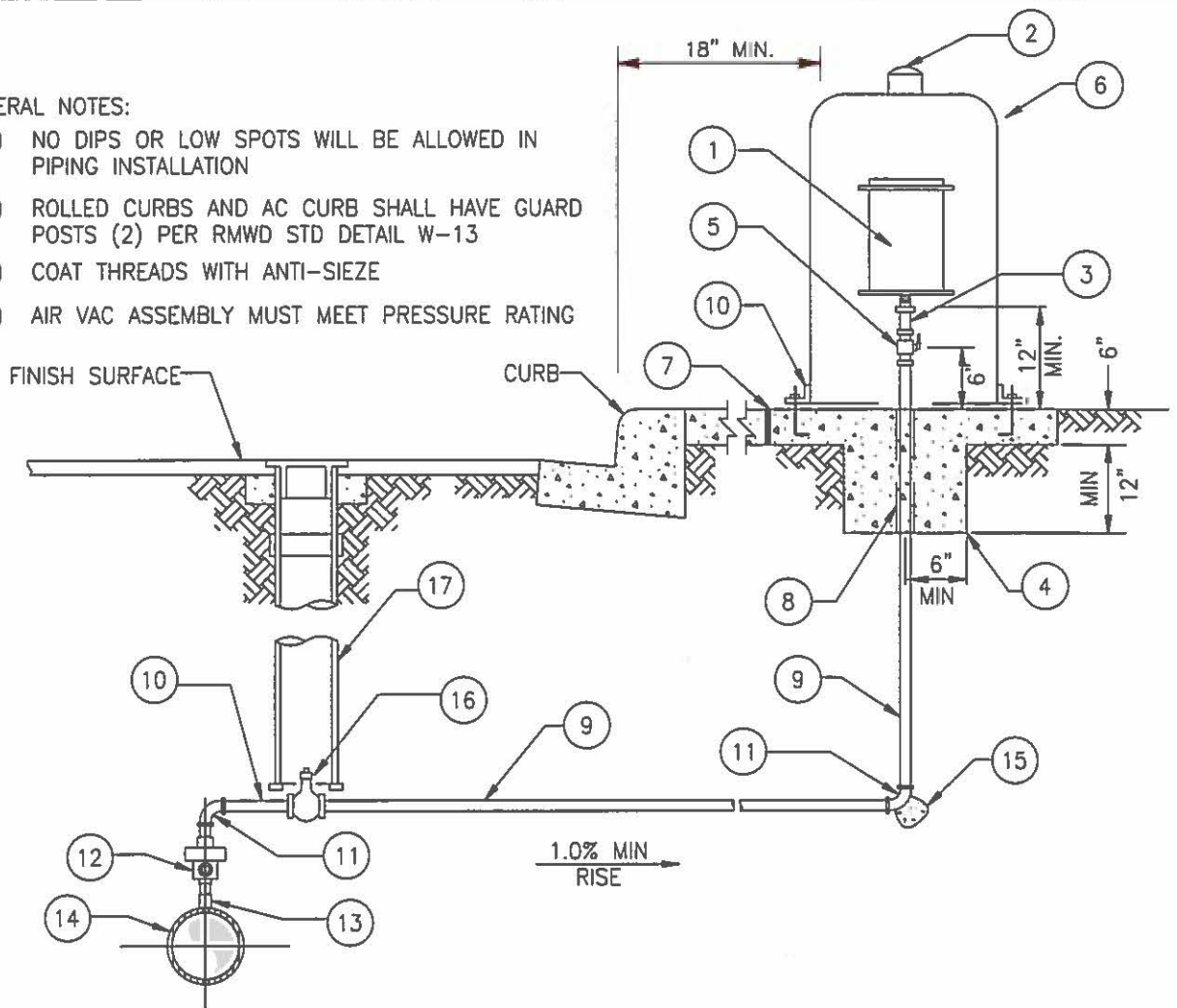

ITEM	SIZE & DESCRIPTION	ITEM	SIZE & DESCRIPTION
1	AUTOMATIC AIR RELEASE AND VACUUM RELIEF VALVE	10	316 SST, BOLTS ON ENCLOSURE RED HEAD
2	GUARD POSTS PER W-13	11	90° BRASS ELL
3	BRASS CLOSE NIPPLE	12	BRASS CORP STOP
4	2 FT SQUARE CONCRETE BASE	13	FORGED STEEL HALF-COUPLING, THREADED, CLASS 3000 WELDED TO PIPE PER W-5. (CML&C PIPE) OR DOUBLE STRAP, STAINLESS STEEL, TAPPING COLLAR (PVC OR DUCTILE IRON)
5	BALL VALVE WITH HANDLE AND SERVICE STOP	14	CML&C OR DIP WATER MAIN
6	HOUSING, 18" DIA. X 30" TALL	15	THRUST BLOCK PER RMWD SECTION 03300
7	1/2" EXPANSION JOINT	16	BALL VALVE
8	PVC SLEEVE, EXTEND 2" BELOW CONCRETE	17	VALVE BOX INSTALLATION PER DISTRICT STD. DWG NO. W-19
9	BRASS PIPE		



RAINBOW MUNICIPAL WATER DISTRICT

APPROVED:	<p>2"</p> <p>AUTOMATIC AIR RELEASE AND VACUUM RELIEF VALVE</p>	STANDARD DRAWING NO.
RCE # 79790 EXP.09/30/2016		W-11
REVISION APPROVED DATE		JULY 2016

NOTES:

- 1) ROLLED CURBS AND AC CURB SHALL HAVE GUARD POSTS (2) PER STD DWG W-13
- 2) NO DIPS OR LOW SPOTS WILL BE ALLOWED IN PIPING INSTALLATION
- 3) COAT THREADS WITH ANTI-SIEZE
- 3) AIR VAC ASSEMBLY MUST MEET PRESSURE RATING

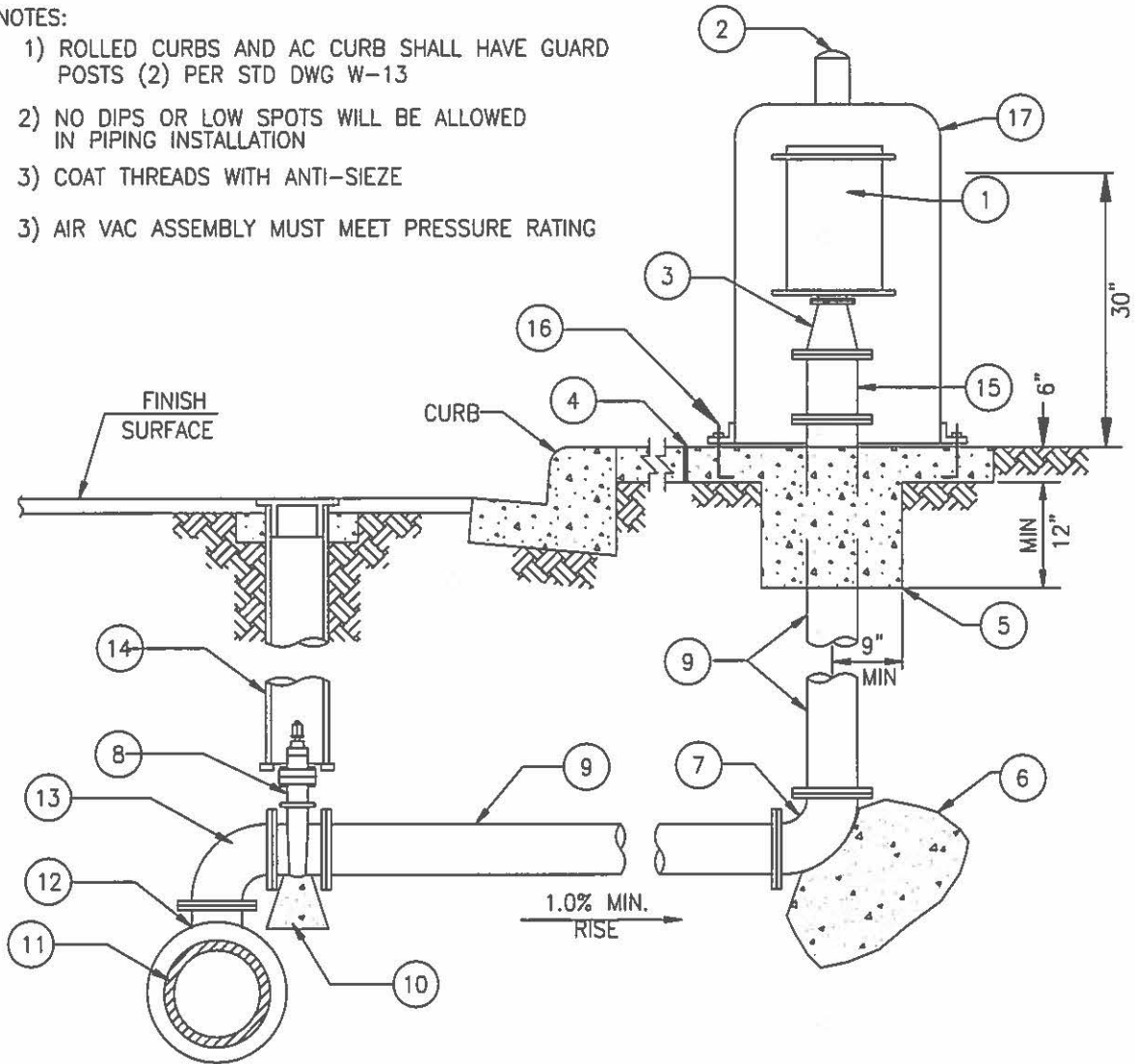

ITEM	SIZE & DESCRIPTION	ITEM	SIZE & DESCRIPTION
1	AUTOMATIC AIR RELEASE AND VACUUM RELIEF VALVE	10	VALVE SUPPORT BLOCK PER RMWD STD DETAIL W-4
2	GUARD POSTS PER W-13	11	STEEL OR DUCTILE IRON WATER MAIN
3	6" x 4" FLG REDUCER IF NEEDED	12	FLG x FLG TEE
4	1/2" EXPANSION JOINT	13	FLG DIP 90° BEND
5	3 FT SQUARE CONCRETE BASE, 560-C-3250	14	VALVE BOX INSTALLATION PER DISTRICT STD. DWG NO. W-19
6	THRUST BLOCK PER RMWD SEC. 03300	15	DIP FLG X FLG SPOOL
7	DIP FLG x FLG 90° BEND	16	316 SST, BOLTS ON ENCLOSURE RED HEAD
8	FL x FL GATE VALVE	17	HOUSING, 24" X 36" TALL, FACE LOCK AWAY FROM CURB
9	DUCTILE IRON PIPE WRAPPED W/ PE		



RAINBOW MUNICIPAL WATER DISTRICT

APPROVED: *Shay Ptakipatit*

RCE # 79790 EXP.09/30/2016

REVISION	APPROVED	DATE

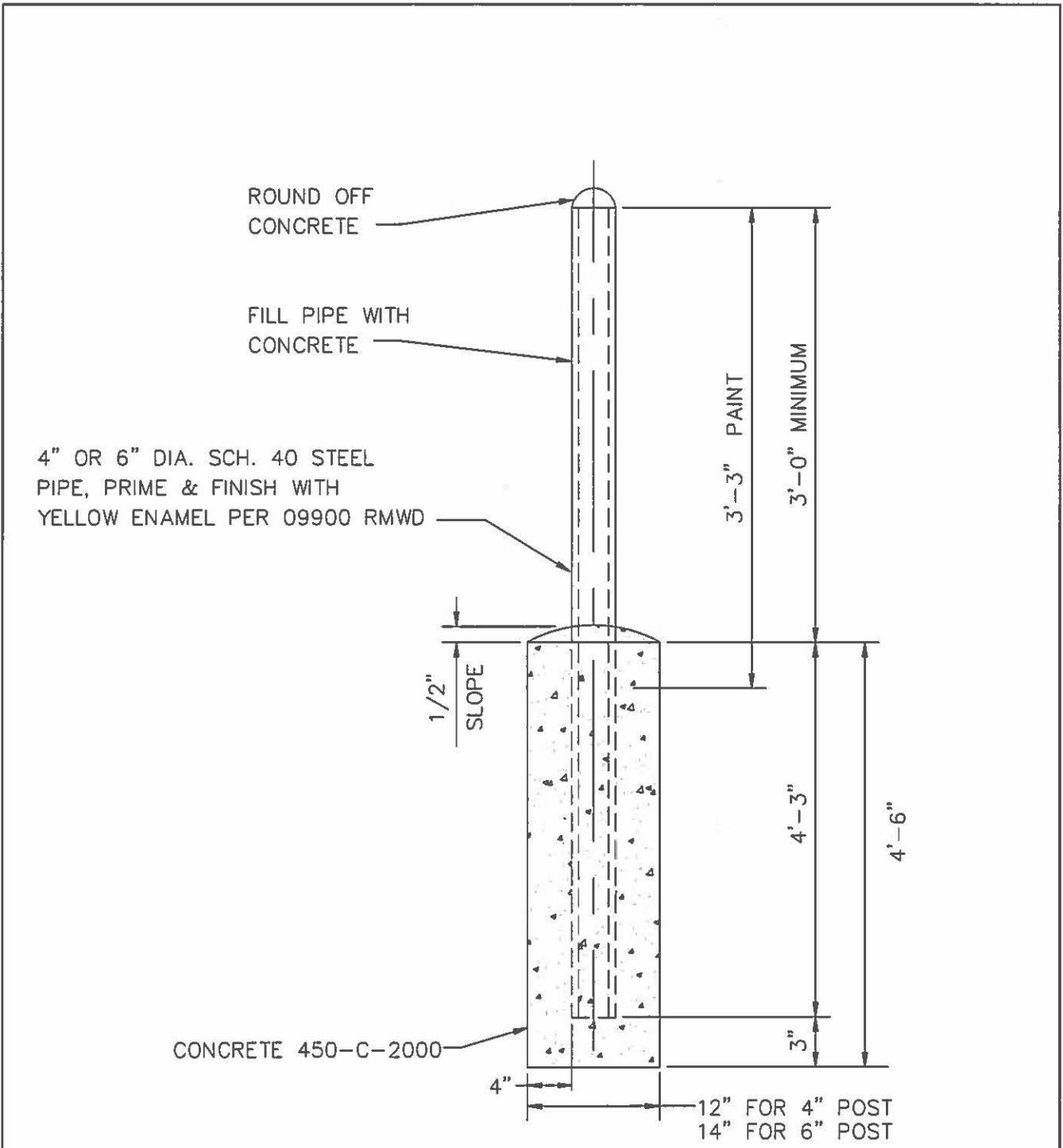

4" AND 6"
AUTOMATIC AIR RELEASE
AND VACUUM RELIEF VALVE

STANDARD DRAWING NO.
W-12
JULY 2016



NOTES:

1. LOCATION SHALL BE AS SHOWN ON PLAN VIEW, OR AS DIRECTED IN THE FIELD BY DISTRICT ENGINEER.
2. 4" DIA. POSTS SHALL BE APPROVED BY D.E. FOR SPEED GREATER THAN 30 MPH 6" DIA. POSTS SHALL BE USED.

 RAINBOW MUNICIPAL WATER DISTRICT		STANDARD DRAWING NO. W-13 JULY 2016						
APPROVED:  RCE # 79790 EXP.09/30/2016 <table border="1" style="width: 100%; border-collapse: collapse;"> <tr> <th style="width: 33%;">REVISION</th> <th style="width: 33%;">APPROVED</th> <th style="width: 33%;">DATE</th> </tr> <tr> <td> </td> <td> </td> <td> </td> </tr> </table>	REVISION	APPROVED	DATE				STANDARD GUARD POST INSTALLATION	
REVISION	APPROVED	DATE						

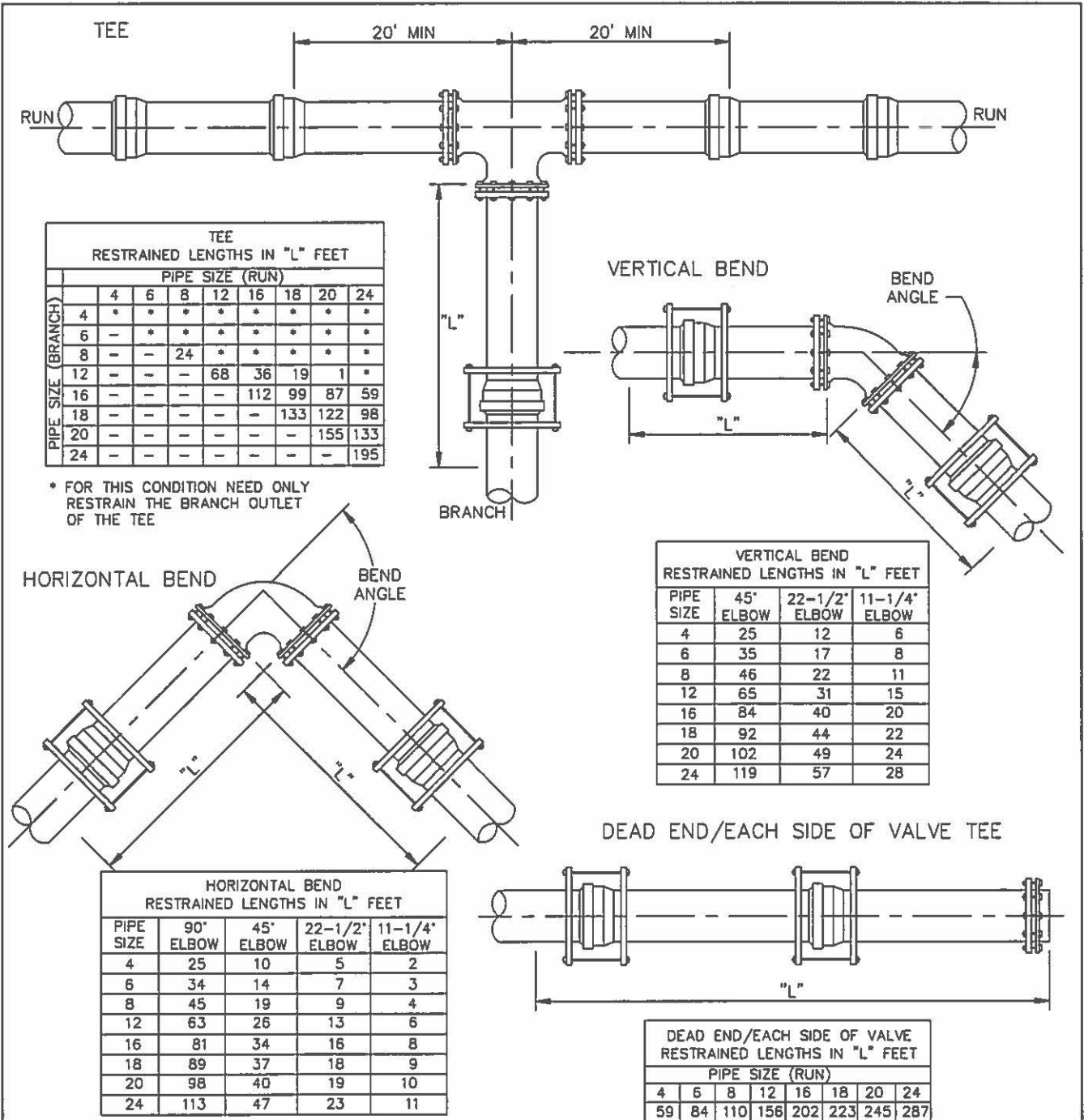

TEE RESTRAINED LENGTHS IN "L" FEET		PIPE SIZE (RUN)							
PIPE SIZE (BRANCH)									
	4	6	8	12	16	18	20	24	
4	*	*	*	*	*	*	*	*	
6	-	*	*	*	*	*	*	*	
8	-	-	24	*	*	*	*	*	
12	-	-	-	68	36	19	1	*	
16	-	-	-	-	112	99	87	59	
18	-	-	-	-	-	133	122	98	
20	-	-	-	-	-	-	155	133	
24	-	-	-	-	-	-	-	195	

* FOR THIS CONDITION NEED ONLY RESTRAIN THE BRANCH OUTLET OF THE TEE

VERTICAL BEND RESTRAINED LENGTHS IN "L" FEET			
PIPE SIZE	45° ELBOW	22-1/2° ELBOW	11-1/4° ELBOW
4	25	12	6
6	35	17	8
8	46	22	11
12	65	31	15
16	84	40	20
18	92	44	22
20	102	49	24
24	119	57	28

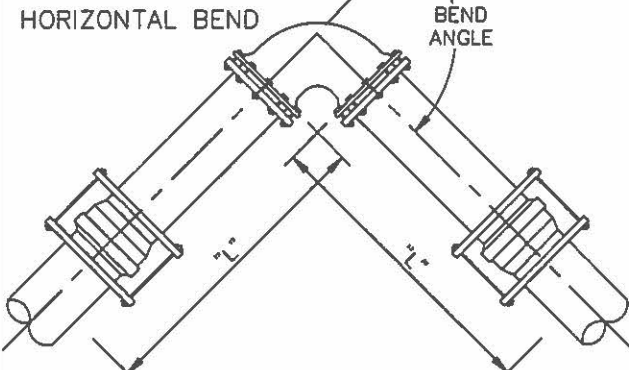

HORIZONTAL BEND RESTRAINED LENGTHS IN "L" FEET				
PIPE SIZE	90° ELBOW	45° ELBOW	22-1/2° ELBOW	11-1/4° ELBOW
4	25	10	5	2
6	34	14	7	3
8	45	19	9	4
12	63	26	13	6
16	81	34	16	8
18	89	37	18	9
20	98	40	19	10
24	113	47	23	11

DEAD END/EACH SIDE OF VALVE TEE

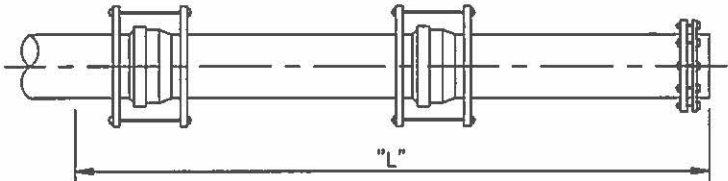

DEAD END/EACH SIDE OF VALVE RESTRAINED LENGTHS IN "L" FEET							
PIPE SIZE (RUN)							
4	6	8	12	16	18	20	24
59	84	110	156	202	223	245	287

NOTES:

1. ALL JOINTS WITHIN LENGTH "L" MUST BE RESTRAINED.
2. FOR TEE RESTRAIN BOTH RUN-SIDE JOINTS AND INSTALL A FULL LENGTH OF PIPE ON EACH SIDE OF BRANCH.
3. FORTY-EIGHT (48) INCHES MINIMUM DEPTH OF COVER.
4. A SAFETY FACTOR OF 1.5.
5. SOIL TYPE ML (INORGANIC SILTS, VERY FINE SANDS, ROCK FLOUR, SILTY OR CLAYEY FINE SANDS) PER UNITED SOIL CLASSIFICATION ASTM D-2487.
 - A. NO BEDDING IN GRANULAR MATERIAL.
 - B. NO USE OF PHI = 0 PRINCIPAL.
6. PIPE BEDDING PER RMWD STANDARD DRAWINGS.
7. TEST PRESSURE 225 PSI.
8. IF ACTUAL CONDITIONS DIFFER FROM THOSE LISTED ABOVE OR THE REQUIRED RESTRAINED LENGTH CANNOT BE MET, THE RESTRAINED LENGTH SHALL BE DETERMINED BY THE DESIGN ENGINEER AND APPROVED BY THE DISTRICT ENGINEER.



RAINBOW MUNICIPAL WATER DISTRICT

APPROVED:		
<i>Shawn Patrick</i>		
RCE # 79790 EXP.09/30/2016		
REVISION	APPROVED	DATE

STANDARD RESTRAINT, TEE,
DEAD END, BEND FOR
PVC C-900 & C905

STANDARD DRAWING NO.
W-14
JULY 2016

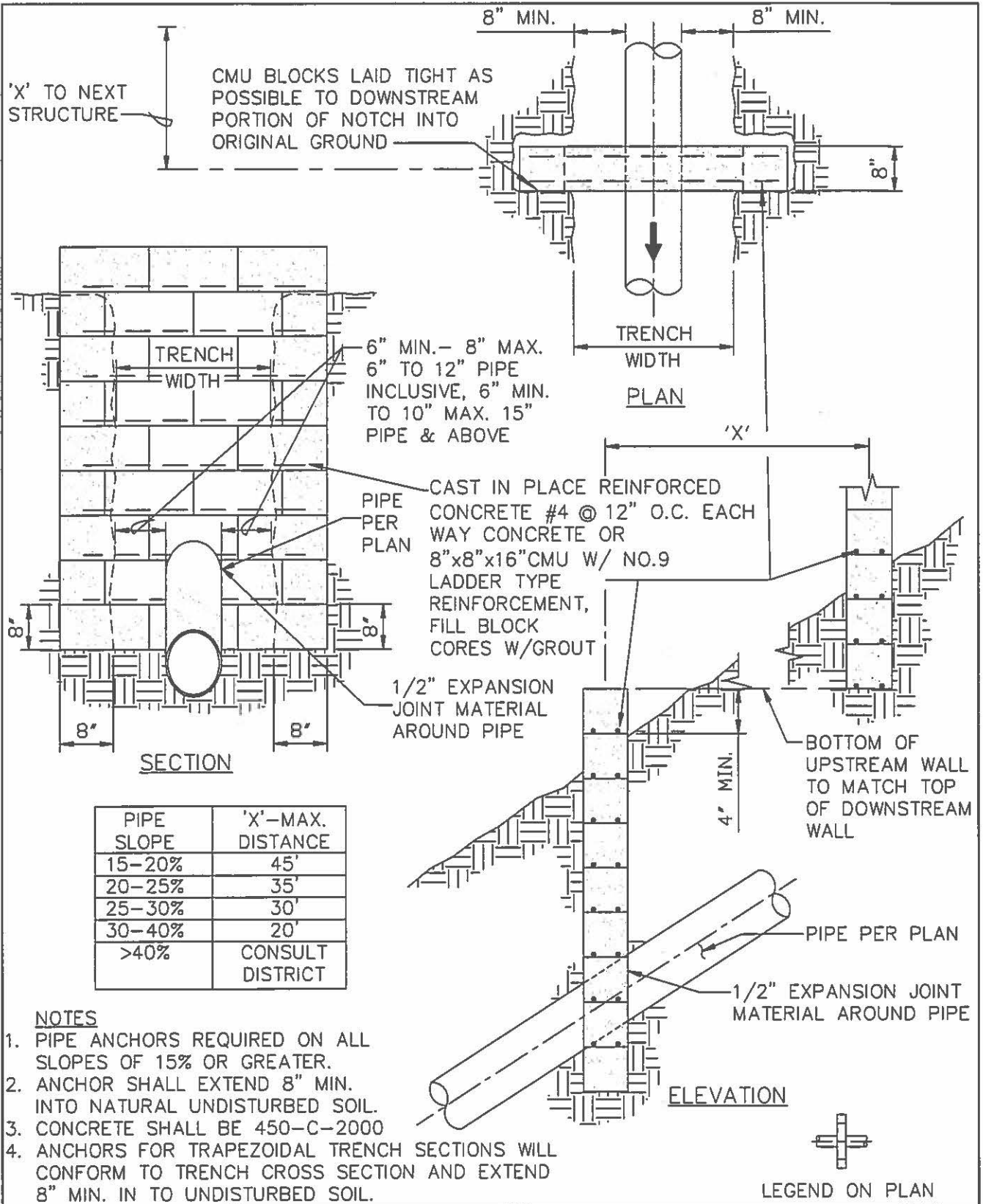

RAINBOW MUNICIPAL WATER DISTRICT
 RAINBOW MUNICIPAL WATER DISTRICT

APPROVED: *[Signature]*

RCE # 79790 EXP.09/30/2016

REVISION	APPROVED	DATE

STANDARD CUTOFF WALL FOR NON PAVED AREA

STANDARD DRAWING NO. **W-15**

JULY 2016

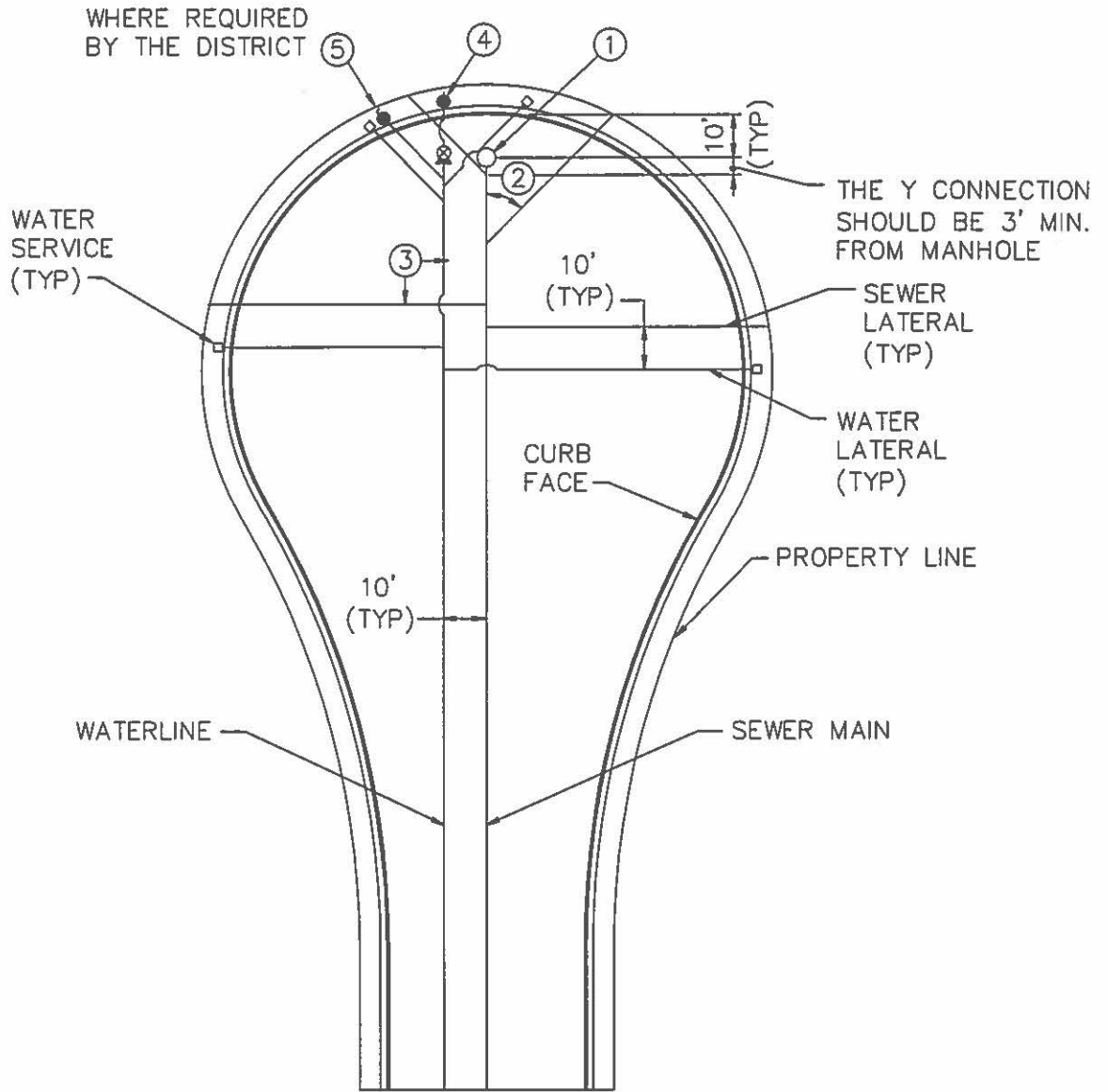

ITEM	DESCRIPTION
1	USE WATER-TIGHT MANHOLE COVER WHERE CUL-DE-SAC CREATES LOW POINT
2	45° ANGLE ONLY IF NECESSARY TO SERVE REAR LOTS (WATER & SEWER)
3	90° ANGLE (STANDARD) (WATER & SEWER)
4	END OF MAIN FIRE HYDRANT (TO SERVE AS A BLOWOFF). LOCATE TO CLEAR DRIVEWAYS
5	END OF MAIN A.V.A.R. (WHERE CUL-DE-SAC CREATES A HIGH POINT).



RAINBOW MUNICIPAL WATER DISTRICT

APPROVED: <i>Shantia Patrick</i>		
RCE # 79790 EXP.09/30/2016		
REVISION	APPROVED	DATE

**STANDARD CUL-DE-SAC
WATER LATERALS**

STANDARD DRAWING NO.
W-17
JULY 2016

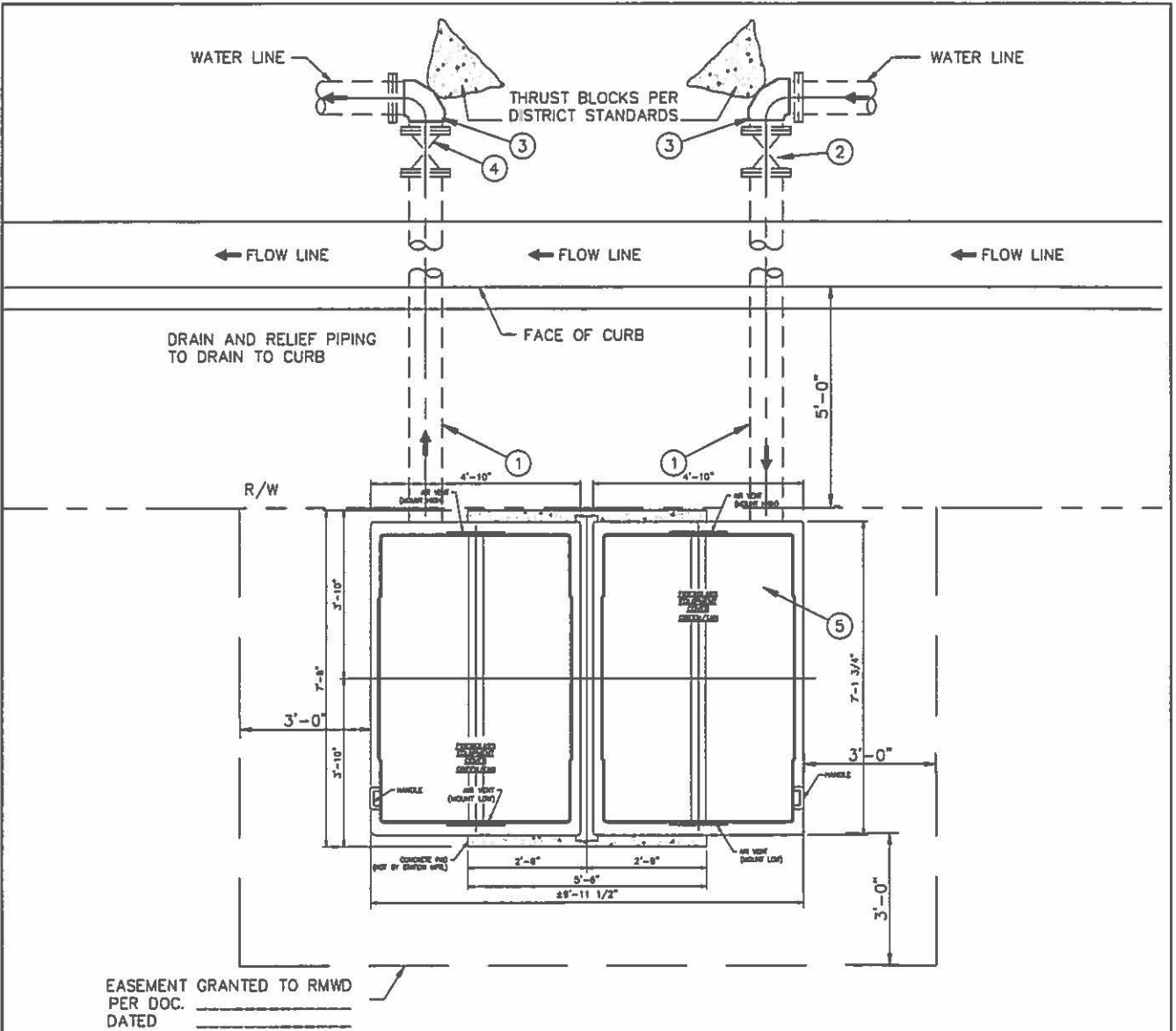

ITEM	SIZE & DESCRIPTION	REMARKS
1	8" DIP OR STEEL PIPE SPOOL	
2	8" PLUG VALVE	
3	90 DEGREE ELBOW, DIP OR STEEL	THRUST BLOCK PER RMWD STD DETAIL W-4
4	8" GATE VALVE	
5	PRE FABRICATED PRESSURE REDUCTION STATION PER DISTRICT STANDARDS	



RAINBOW MUNICIPAL WATER DISTRICT

STANDARD PRESSURE REDUCING STATION

STANDARD DRAWING NO.

W-18

JULY 2016

APPROVED: *Shawn P. Kunkel*

RCE # 79790 EXP.09/30/2016

REVISION	APPROVED	DATE

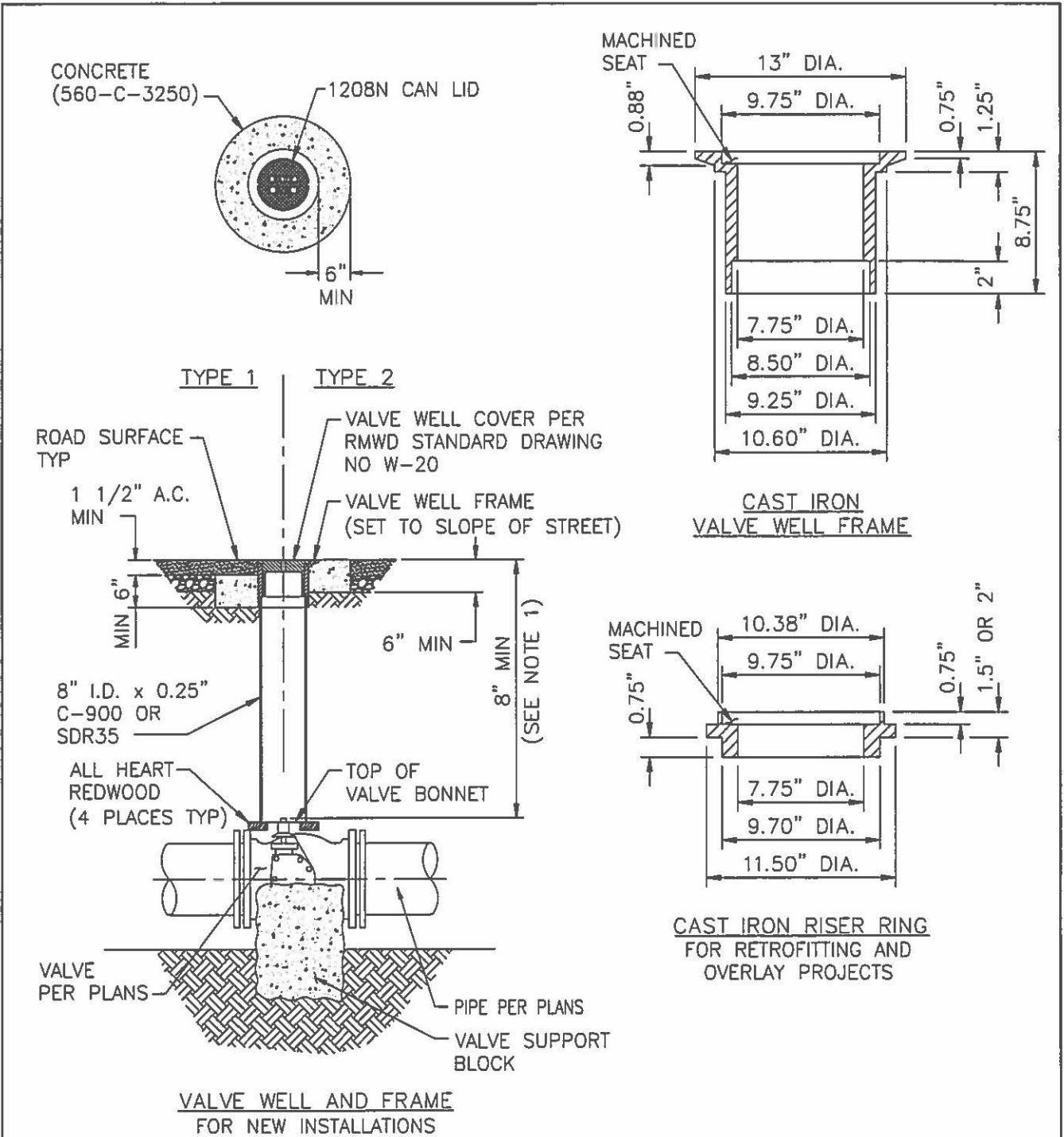

NOTES:

1. FOR GATE VALVES, PROVIDE VALVE KEY EXTENSION WHERE THIS DIMENSION EXCEEDS 9 FEET.
2. THE SURFACE OF THE VALVE WELL COVER SHALL MATCH THE STREET CROSS SLOPE AND PROFILE.



RAINBOW MUNICIPAL WATER DISTRICT

APPROVED:		
<i>Shawn Patrick</i>		
RCE # 79790 EXP.09/30/2016		
REVISION	APPROVED	DATE

VALVE WELL FRAME

STANDARD DRAWING NO.
W-19
JULY 2016

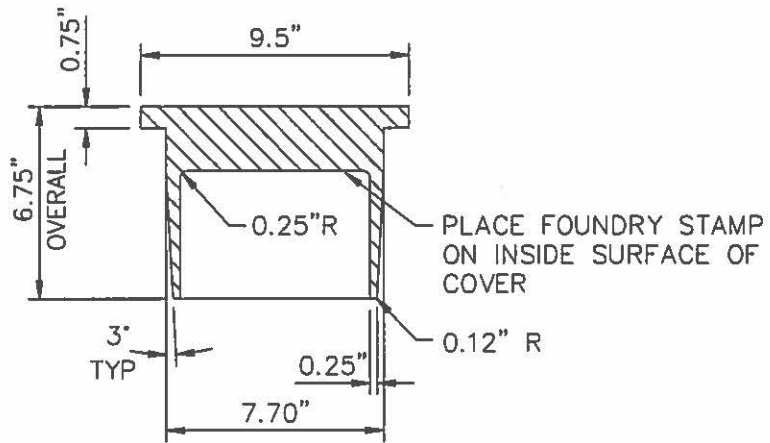
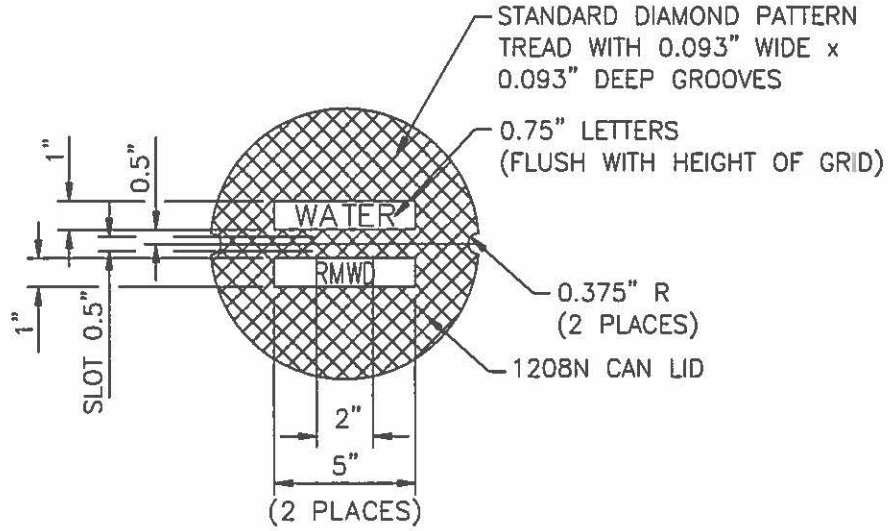

VALVE WELL COVER PAINT CHART

<u>INLINE VALVES</u>	<u>AIR VACS</u>	<u>B.O.s AND HYDRANTS</u>
WHITE	YELLOW	RED



RAINBOW MUNICIPAL WATER DISTRICT

APPROVED: <i>Shawn Patrick</i>		
RCE # 79790 EXP.09/30/2016		
REVISION	APPROVED	DATE

VALVE WELL COVER

STANDARD DRAWING NO.
W-20
JULY 2016

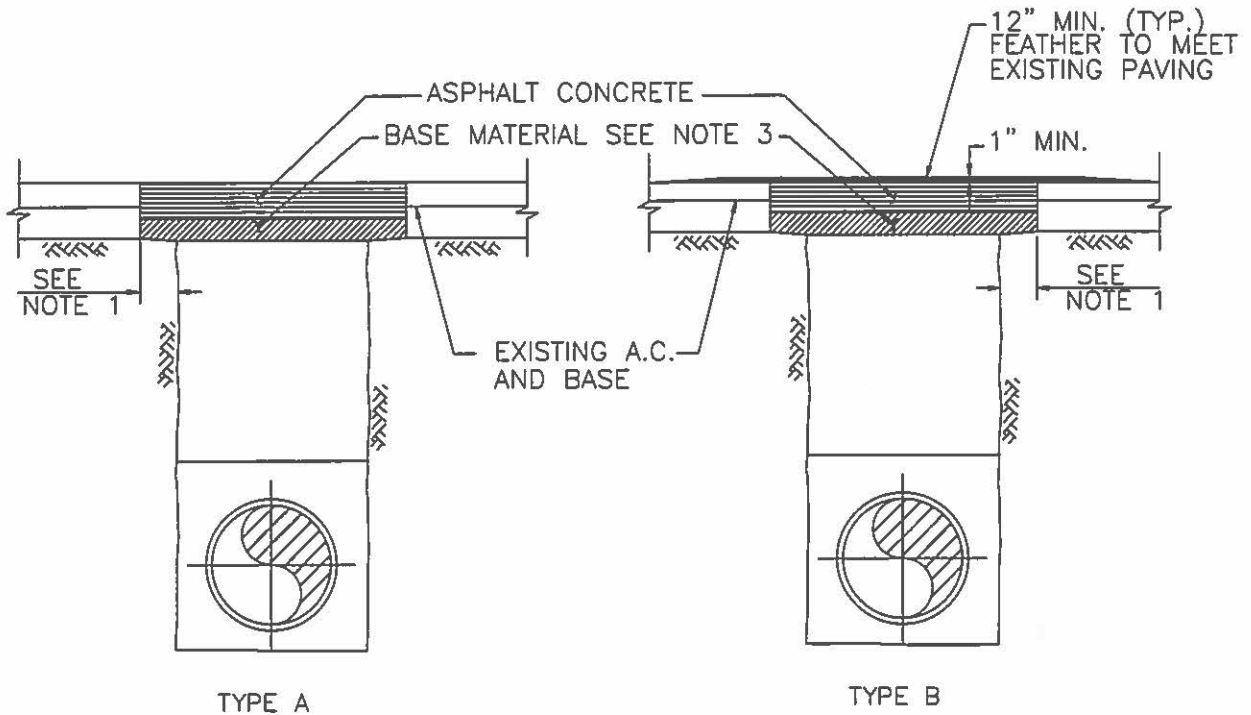

NOTES:

- 1) TRENCH EDGES TO BE CUT A MINIMUM OF 6" WIDER THAN TRENCH FOR TRENCHES 3' WIDE OR LESS, AND 12" WIDER FOR TRENCHES OVER 3' WIDE.
- 2) EXISTING AC SHALL BE CUT AND REMOVED IN SUCH A MANNER SO AS NOT TO TEAR, BULGE OR DISPLACE ADJACENT PAVEMENT. EDGES SHALL BE CLEAN AND VERTICAL. ALL CUTS SHALL BE PARALLEL OR PERPENDICULAR TO STREET CENTERLINE, WHEN PRACTICAL.
- 3) BASE MATERIAL TO BE REPLACED TO DEPTH OF EXISTING BASE OR 6" MINIMUM, AC MAY BE SUBSTITUTED FOR BASE MATERIAL.
- 4) A TACK COAT OF ASPHALT EMULSION OR PAVING ASPHALT SHALL BE APPLIED TO EXISTING AC OR P.C.C. CONTACT SURFACES, PRIOR TO RESURFACING.
- 5) ASPHALT CONCRETE RESURFACING:
 - A) MINIMUM TOTAL THICKNESS SHALL BE ONE INCH GREATER THAN EXISTING AC OR 3" MINIMUM,
 - B) AC SHALL BE HOT PLANT MIX CALTRANS SPEC GRADE C2-PG-64-10.
 - C) FINISH COURSE FOR TYPE B RESURFACING SHALL BE LAID DOWN USING A SPREADER BOX.
- 6) ALL AC RESURFACING SHALL BE SEAL COATED WITH AN EMULSIFIED ASPHALT AND COVERED WITH SAND. CHIP SEALING TO BE APPLIED AS REQUIRED BY AGENCY.
- 7) TYPE B SHALL NOT BE USED ON LATERAL CROSSINGS.
- 8) SLOUGHING OF TRENCH UNDER PAVEMENT SHALL BE CAUSE FOR REQUIRING ADDITIONAL PAVEMENT AND BASE.



RAINBOW MUNICIPAL WATER DISTRICT

APPROVED: <i>Shawn K. Kunkel</i>		
RCE # 79790 EXP. 09/30/2016		
REVISION	APPROVED	DATE

TRENCH RESURFACING
TYPES A & B

STANDARD DRAWING NO.
W-21
JULY 2016

FOR DRAWING OF FIRE SERVICE INSTALLATION SEE W22A

NOTES:

- 1) REFER TO SECTION 15112 OF THE SPECIFICATIONS
- 2) INSTALL WARNING/IDENTIFICATION TAPE AS SHOWN ON W-3
- 3) LOCATION OF FIRE SERVICES SHALL BE AS DIRECTED BY THE FIRE DEPARTMENT OF JURISDICTION. FIRE SERVICES SHOULD BE LOCATED IN SUCH A MANNER THAT WILL ALLOW THE DEVICE TO BE READILY ACCESSIBLE FOR INSPECTION, REPAIR, AND USAGE.
- 4) TAMPER SWITCH, AUTOMATIC RESET, CHAIN WITH KNOX LOCK, AND FIRE DEPARTMENT CONNECTION ("FDC") SHALL BE AS REQUIRED BY THE FIRE DEPARTMENT OF JURISDICTION.
- 5) BALL VALVE TEST COCKS SHALL BE PROVIDED AND LOCATED PER THE MANUFACTURES RECOMMENDATIONS AND THE REQUIREMENTS OF THE WATER AGENCY STANDARDS.
- 6) INSTALL FIRE SERVICES SO THAT THE DISTANCE BETWEEN THE BOTTOM OF THE RELIEF DIAPHRAGM AND THE CONCRETE SLAB OR FINISH GRADE IS 12" MIN. AND 36" MAX.
- 7) INSTALL AN ANGLE PRESSURE REDUCING VALVE IN LIEU OF THE FIRST 90° BEND WHEN SYSTEM STATIC PRESSURE EXCEEDS 175psi OR WHEN RECOMMENDED BY THE BACKFLOW MANUFACTURER
- 8) INSTALL PIPE AND RELATED APPURTENANCES IN THIS AREA PER THE REQUIREMENT OF THE RMWD SPECIFICATIONS.
- 9) INSTALL PIPE AND RELATED APPURTENANCES IN THIS AREA AS REQUIRED BE THE FIRE DEPARTMENT OF JURISDICTION.
- 10) ABOVE GROUND APPURTENANCE SHALL BE PAINTED AND IDENTIFIED AS CALLED FOR BY THE FIRE DEPARTMENT OF JURISDICTION.
- 11) TESTING SHALL BE CONDUCTED AS CALLED FOR IN SECTION 15112 OF THE SPECIFICATIONS PRIOR TO ACCEPTANCE BY THE DISTRICT.
- 12) MATERIALS SHALL BE SELECTED FORM THE APPROVED MATERIALS LIST.
- 13) DISTRICT RESPONSIBILITY ENDS AT EDGE OF PROPERTY LINE, RIGHT OF WAY, OR EASEMENT.

ITEM NO.	SIZE AND DESCRIPTION	ITEM NO.	
①	CONCRETE THRUST BLOCK SEE W-4	⑪	FLANGED 90° BEND, SEE NOTE 7
②	WATER MAIN	⑫	FLG'D OS&Y RWGV WITH HAND WHEEL
③	GATE WELL SEE W-19	⑬	RPDA SEE NOTE 4
④	SIZE X SIZE FLG X FLG TEE	⑭	CHAIN WITH LOCK SEE NOTE 4
⑤	FLG X FLG RWGV	⑮	FLANGED TEE WITH "FDC" SEE NOTE 4
⑥	FLG X MJ/PO ADAPTER (IF REQUIRED)	⑯	CONCRETE SLAB, 4" THICK X 48" WIDE, 520-C-2500
⑦	DI OR STEEL	⑰	3/4" BYPASS, METER & DOUBLE CHECK VALVE OR RP DEVICE
⑧	FLG X FLG 90° BEND	⑱	ADJUSTABLE VALVE SUPPORT
⑨	FLANGED DUCTILE IRON PIPE	⑲	DI PIPE SEE NOTE 9
⑩	1/2" EXPANSION JOINT	⑳	FLANGED ANGLE PRESSURE REDUCING VALVE SEE NOTE 7



RAINBOW MUNICIPAL WATER DISTRICT

APPROVED:		4" AND LARGER FIRE SERVICE INSTALLATION	STANDARD DRAWING NO.
			W-22B
RCE # 79790 EXP.09/30/2016			JULY 2016
REVISION	APPROVED	DATE	

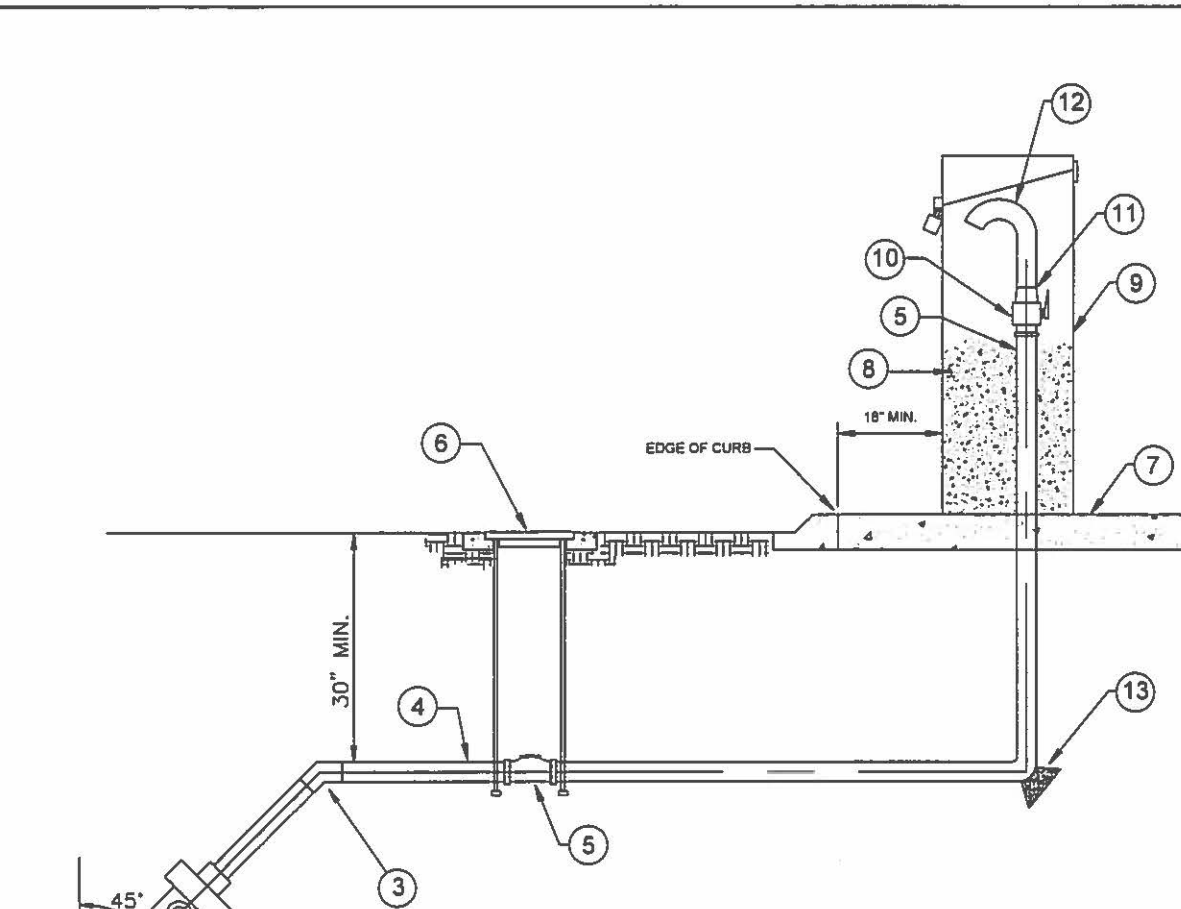

MATERIAL LIST

- ① FORGED STL HALF-COUPLING, THREADED, CLASS 3000 WELDED TO PIPE PER W-5. (CML&C PIPE) OR DOUBLE STRAP STAINLESS STL. TAPPING COLLAR (PVC OR DUCTILE IRON)
- ② CORP STOP
- ③ 45° BRASS ELBOW
- ④ BRASS PIPE
- ⑤ BRASS SERVICE STOP
- ⑥ VALVE BOX PER W-19 & W-20
- ⑦ 4 x 4 HOUSE KEEPING PAD
- ⑧ PEA GRAVEL
- ⑨ STL WATER TEST CANISTER (EPOXY POWDER COATED) WITH LOCKING CAPABILITY
- ⑩ 1" BRONZE BALL VALVE CLASS 125
- ⑪ 1-3/8" BRASS REDUCING BUSHING
- ⑫ GOOSE NECK
- ⑬ THRUST BLOCK PER RMWD SECTION 03300



RAINBOW MUNICIPAL WATER DISTRICT

APPROVED: _____		
RCE # 79790 EXP.09/30/2016		
REVISION	APPROVED	DATE

WATER SAMPLING STATION

STANDARD DRAWING NO.
W-24
JULY 2016

NOTES:

1. REFER TO SECTION 15000 OF THE SPECIFICATIONS.
2. TRACER WIRE TO RUN CONTINUOUSLY ALONG THE ENTIRE LENGTH OF WATER MAINS. WIRE SHALL BE SECURED TO THE PIPE AND MAINTAINED ON PIPE CENTERLINE DURING TRENCH BACKFILL.
3. TRACER WIRE ACCESS PORTS TO BE INSTALLED WITHIN THE CONCRETE SPLASH PAD OF ALL FIRE HYDRANTS IN ACCORDANCE WITH THE STANDARD DRAWINGS. TRACER WIRE MAY TERMINATE IN A TRACER WIRE ACCESS PORT IN A 4'X4' CONCRETE HOUSEKEEPING PAD ONLY IF NO OTHER APPURTENANCE EXISTS WITHIN THE REQUIRED 305m (1000') INTERVAL. ALL BURIED WIRES THAT REQUIRE TRENCHING TO A TEST BOX LOCATION SHALL BE INSTALLED WITHOUT SPLICE, IN A CONDUIT IN THE TRENCH AT A MINIMUM DEPTH OF 600mm (24").
4. WIRE SPLICE CONNECTORS SHALL BE SILICONE FILLED TYPE DBR-6 OR APPROVED EQUAL.
5. WARNING/IDENTIFICATION TAPE SHALL BE INSTALLED 300mm (12") ABOVE THE PIPE AND RUN CONTINUOUSLY ALONG THE ENTIRE LENGTH OF THE PIPE AND ALL RELATED APPURTENANCES IN ACCORDANCE WITH SECTION 15064.
6. FOR PIPE BEDDING AND TRENCH BACKFILL SEE W-3.
7. FOR INSTALLATION OF WARNING/IDENTIFICATION ON SEWER LINES SEE S-1.
8. MATERIALS SHALL BE SELECTED FROM THE APPROVED MATERIALS LIST.

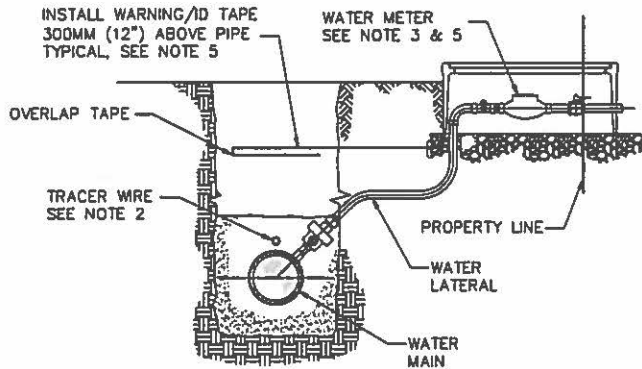

SECTION AT WATER LATERALS

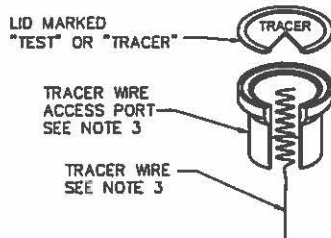

TRACER WIRE ACCESS PORT DETAIL

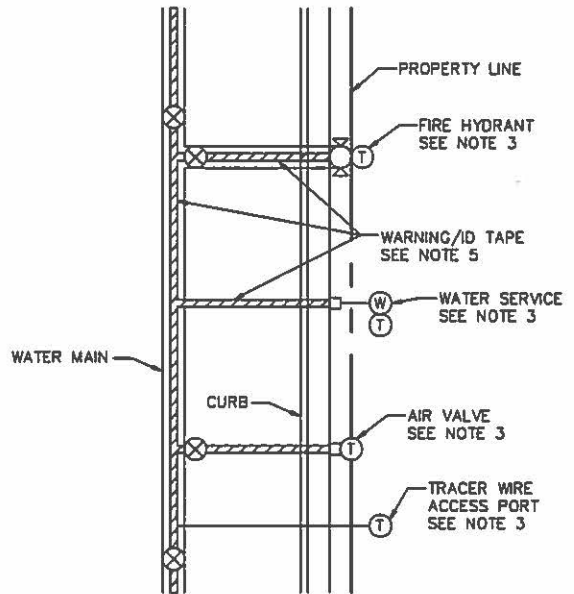

PLAN



RAINBOW MUNICIPAL WATER DISTRICT

APPROVED: <i>Shawn P. Kirkpatrick</i>		
RCE # 79790 EXP.09/30/2016		
REVISION	APPROVED	DATE

**WARNING IDENTIFICATION TAPE
AND TRACER WIRE INSTALLATION**

STANDARD DRAWING NO.
W-25
JULY 2016

CATHODIC PROTECTION

DRAWINGS

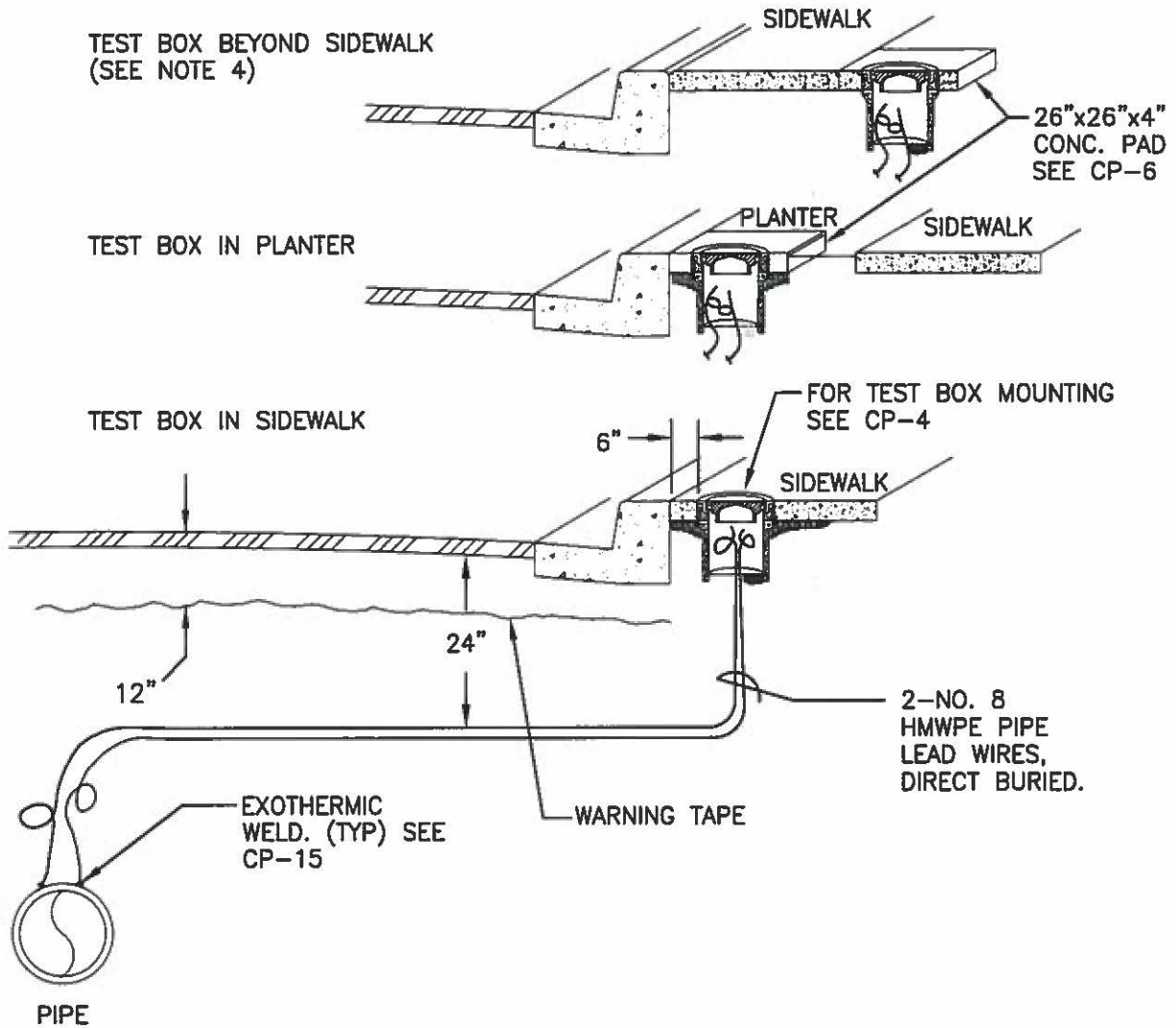

NOTES:

1. PROVIDE 18" SLACK WIRE AT WELD AND COILED IN TEST BOX.
2. WIRE TRENCH SHALL BE 24-INCHES DEEP (MIN). PLACE 3-INCHES OF SAND OR DG BEDDING IN TRENCH BEFORE PLACING WIRES. COVER WIRES WITH 6-INCHES OF SAND OR DG. COMPACT WIRE TRENCH FILL PER RWD-STD.
3. USE 6" WIDE, 4 MIL THICK INERT PLASTIC TAPE PRINTED WITH "CAUTION: CATHODIC PROTECTION CABLE BELOW". PLACE 12-INCHES BELOW GRADE.
4. TEST BOX TO BE PLACED BEHIND CURB IN SIDEWALK, BEYOND EDGE OF SIDEWALK, OR IN PLANTER AS SHOWN PER ENGINEER'S DIRECTION. IF NO CURB EXISTS, LOCATE TEST BOX JUST OFF PAVED SURFACE. IN UNPAVED AREAS OR PARKING LOTS, LOCATE TEST BOX OVER PIPE BUT NOT DIRECTLY IN PARKING SPACE. (SEE CP-2).



RAINBOW MUNICIPAL WATER DISTRICT

APPROVED:		
<i>[Signature]</i>		
RCE # 79790 EXP.09/30/2016		
REVISION	APPROVED	DATE

2-WIRE TEST STATION
(PAVED STREET)

STANDARD DRAWING NO.
CP-1
JANUARY 2016

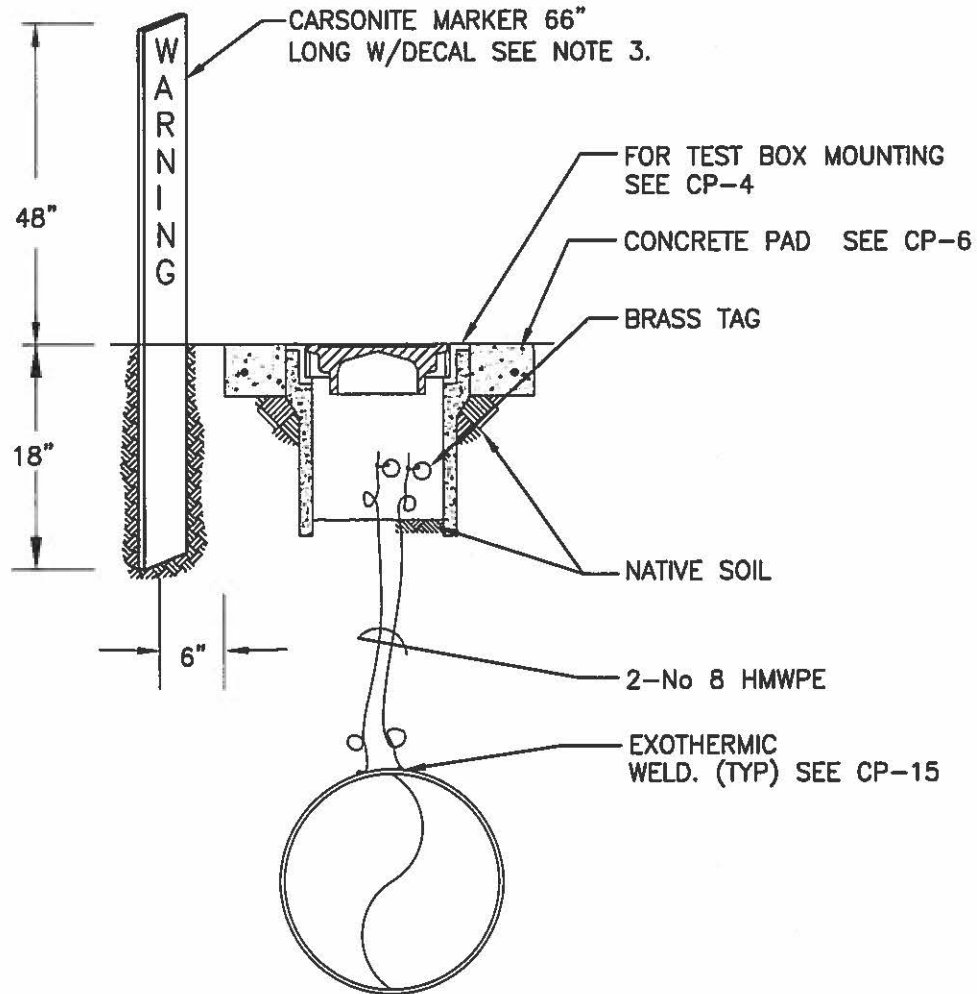

NOTES:

1. PLACE TEST STATION DIRECTLY OVER PIPE IF POSSIBLE.
2. SEE NOTES 1 THROUGH 4 ON CP-1.
3. CARSONITE MODEL R-845, YELLOW WITH BLACK CHARACTERS WITH: "RAINBOW MUNICIPAL WATER DISTRICT, UNDERGROUND CABLES, WARNING, BEFORE DIGGING CALL DIG ALERT AT 811."



RAINBOW MUNICIPAL WATER DISTRICT

APPROVED: <i>[Signature]</i>		
RCE # 79790 EXP.09/30/2016		
REVISION	APPROVED	DATE

2-WIRE TEST STATION
(UNPAVED AREA)

STANDARD DRAWING NO.
CP-2
JANUARY 2016

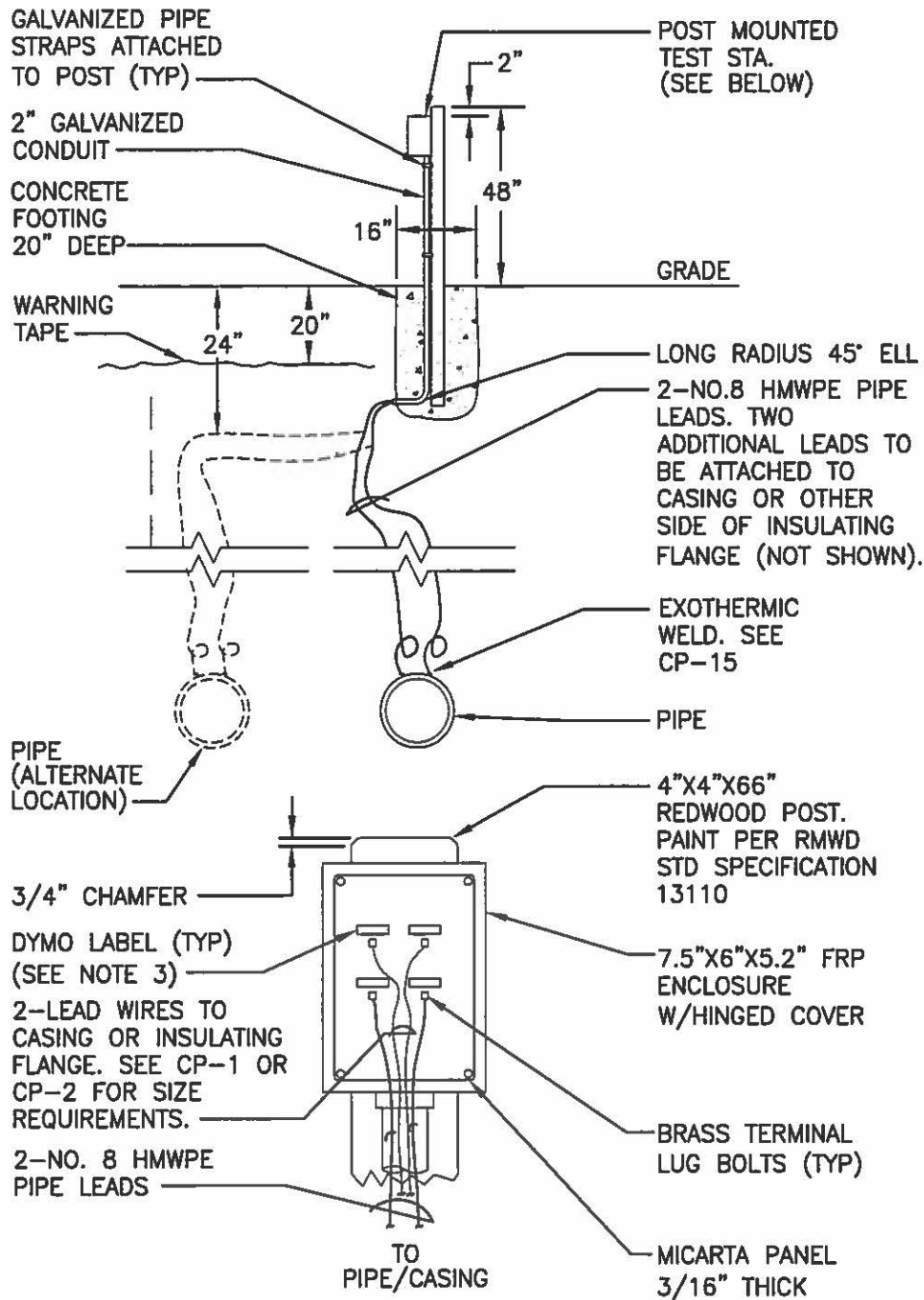

NOTES:

1. INSTALL TEST STATION OVER PIPE IF POSSIBLE. OFFSET POST AS NECESSARY TO PLACE IN PROTECTED AREA AND OUT OF TRAFFIC LANES. BUT NOT OUTSIDE RIGHT-OF-WAY.
2. FOUR-WIRE TEST STATION SHOWN IS APPLICABLE TO CASING AND INSULATING FLANGE TEST STATIONS (SEE CP-7 AND CP-5). TWO WIRE TEST STATIONS SIMILAR.
3. EACH WIRE SHALL BE IDENTIFIED WITH A DYMO LABEL AFFIXED TO THE MICARTA PANEL. LABEL WILL IDENTIFY RWD, SIZE, MATL AND SERVICE (I.E. RMWD, 14", CML&C, RW)



RAINBOW MUNICIPAL WATER DISTRICT

APPROVED: <i>[Signature]</i>		
RCE # 79790 EXP.09/30/2016		
REVISION	APPROVED	DATE

2 OR 4-WIRE TEST STATION

STANDARD DRAWING NO.
CP-3
JANUARY 2016

CAST IRON TRAFFIC COVER MARKED "CP TEST" OR "TRACER"

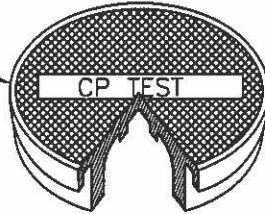

CONCRETE PAD (SEE NOTE 6)

NO. 4 REBAR (TYP) 2" COVER

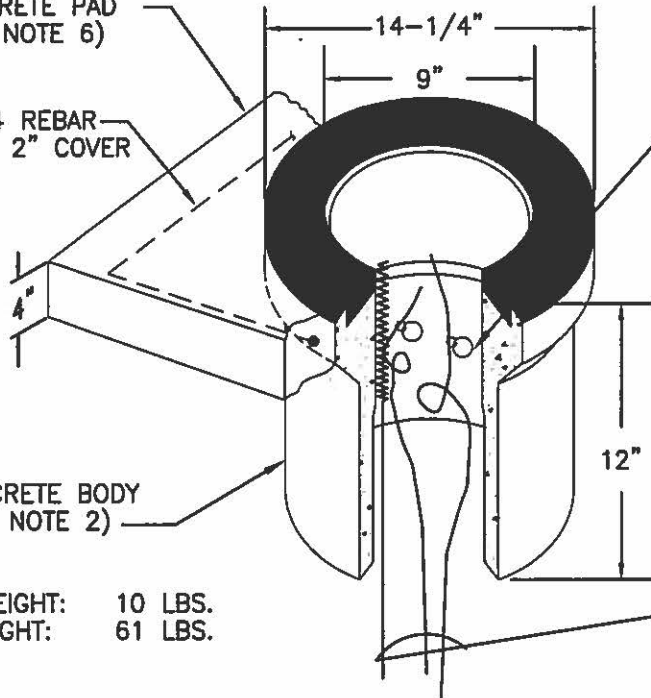

BRASS TAGS 1-1/2" DIA WITH 1/8" HOLE. STAMP WITH "RWD, SIZE, MATL, SERVICE"

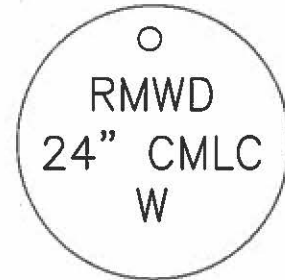

CONCRETE BODY (SEE NOTE 2)

COVER WEIGHT: 10 LBS.
BODY WEIGHT: 61 LBS.

2 NO. 8 AWG HMWPE TEST LEADS AND/OR 1 NO. 8 AWG HMWPE TRACER WIRE

NOTES:

1. SEE CP-1 FOR PLACEMENT OF TEST BOX ON PAVED STREETS AND CP-2 FOR REPLACEMENT IN UNPAVED AREAS.
2. CONCRETE BODY, RATED FOR OCCASIONAL VEHICLE TRAFFIC.
3. ALL WIRES SHALL HAVE 24" MIN. SLACK IN BOX.
4. BOTTOM OF TEST BOX SHALL BE NATIVE SOIL. DO NOT PLACE ROCK, GRAVEL OR SAND IN TEST BOX.
5. FIRMLY STAMP BRASS TAGS (1-1/2" DIA WITH 1/16" DIA. HOLE) "RWD, SIZE AND SERVICE" (EXAMPLE: RMWD 24" W). USE 1/4" HIGH CHARACTERS. SECURELY ATTACH BRASS TAGS TO TEST LEADS WITH BARE NO. 14 COPPER WIRE.
6. PROVIDE 26" x 26" x 4" THICK REINFORCED CONCRETE PAD AROUND TEST BOXES AT UNPAVED SITES. CONCRETE SHALL BE 560-C-3250.



RAINBOW MUNICIPAL WATER DISTRICT

APPROVED: <i>[Signature]</i>		
RCE # 79790 EXP.09/30/2016		
REVISION	APPROVED	DATE

AT GRADE TEST BOX

STANDARD DRAWING NO.
CP-4
JANUARY 2016

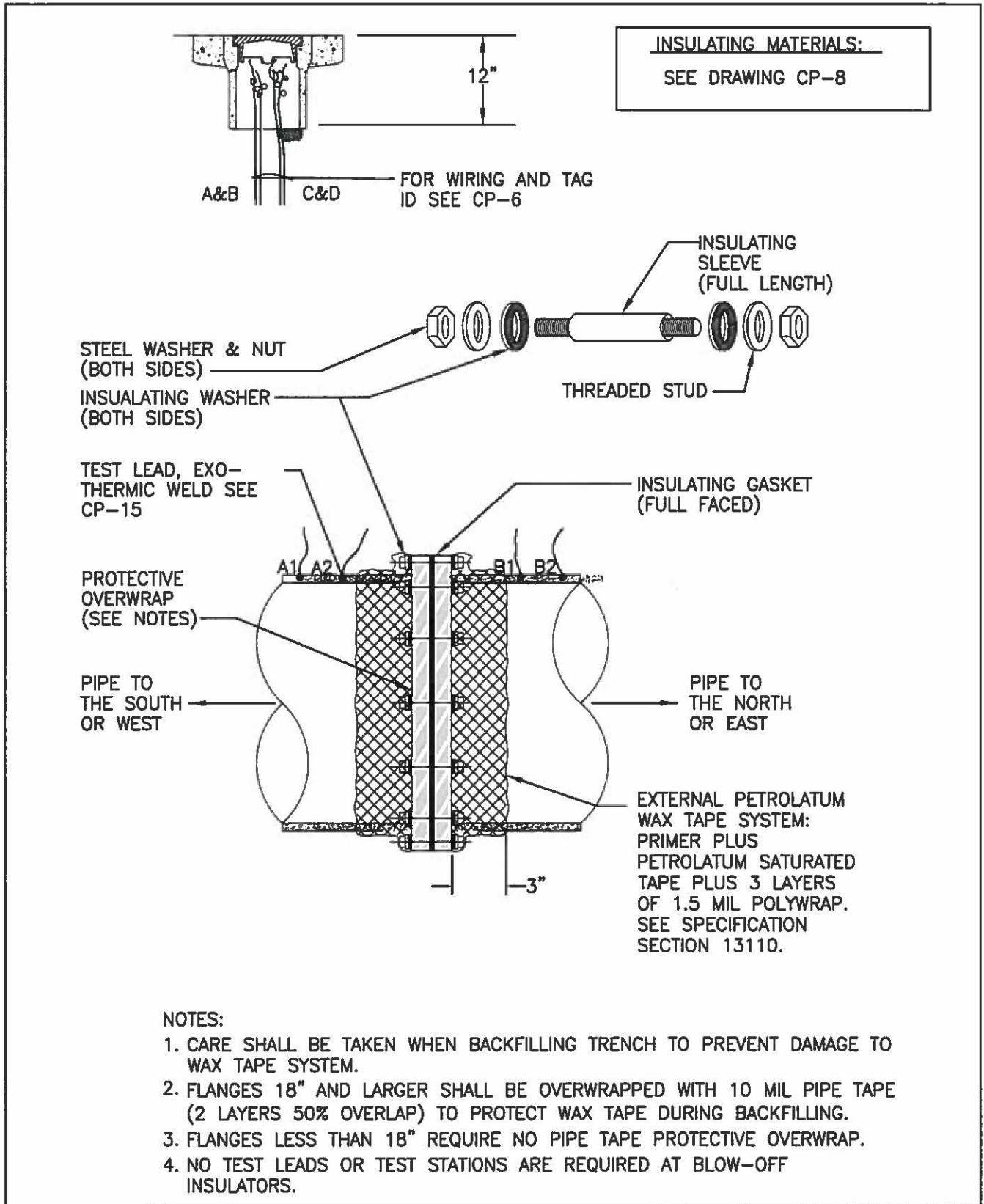

NOTES:

1. CARE SHALL BE TAKEN WHEN BACKFILLING TRENCH TO PREVENT DAMAGE TO WAX TAPE SYSTEM.
2. FLANGES 18" AND LARGER SHALL BE OVERWRAPPED WITH 10 MIL PIPE TAPE (2 LAYERS 50% OVERLAP) TO PROTECT WAX TAPE DURING BACKFILLING.
3. FLANGES LESS THAN 18" REQUIRE NO PIPE TAPE PROTECTIVE OVERWRAP.
4. NO TEST LEADS OR TEST STATIONS ARE REQUIRED AT BLOW-OFF INSULATORS.



RAINBOW MUNICIPAL WATER DISTRICT

APPROVED: <i>[Signature]</i>		
RCE # 79790 EXP.09/30/2016		
REVISION	APPROVED	DATE

BURIED INSULATING FLANGE

STANDARD DRAWING NO.
CP-5
JANUARY 2016

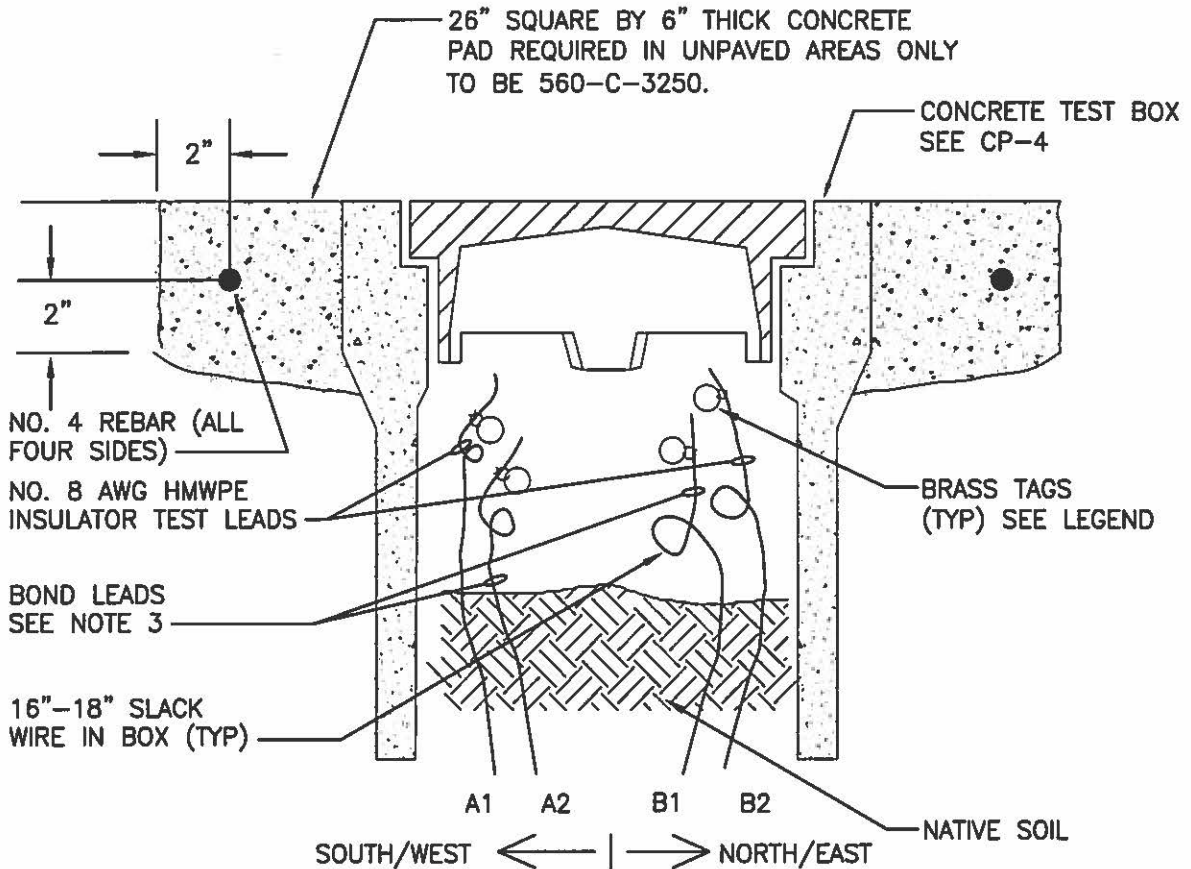

BRASS TAG LEGEND

WIRE	SIZE	ID STAMP
A1	NO. 8	"RMWD, SIZE, MATL, SERVICE, SO. OR WT."
A2	SEE NOTE 3	"RMWD, SIZE, MATL, SERVICE, SO. OR WT."
B1	SEE NOTE 3	"RMWD, SIZE, MATL, SERVICE, NO. OR ET."
B2	NO. 8	"RMWD, SIZE, MATL, SERVICE, NO. OR ET."

EXAMPLE: "RMWD 42" W-ET"

NOTES:

1. SEE CP-1 FOR PLACEMENT OF TEST BOX.
2. SEE CP-4 FOR MOUNTING AND BRASS ID TAG REQUIREMENTS.
3. SECOND WIRE (A2 & B1) ON EACH SIDE OF INSULATOR IS SIZED FOR POSSIBLE FUTURE BOND AS FOLLOWS:

WIRE	PIPE DIA	SIZE
A1 & B1	LESS THAN 12"	NO. 6 AWG HMWPE
	12" TO 18"	NO. 4 AWG HMWPE
	GREATER THAN 18"	NO. 2 AWG HMWPE



RAINBOW MUNICIPAL WATER DISTRICT

APPROVED:	<i>[Signature]</i>	
RCE # 79790 EXP.09/30/2016		
REVISION	APPROVED	DATE

BURIED INSULATING FLANGE
AT-GRADE TEST STATION

STANDARD DRAWING NO.
CP-6
JANUARY 2016

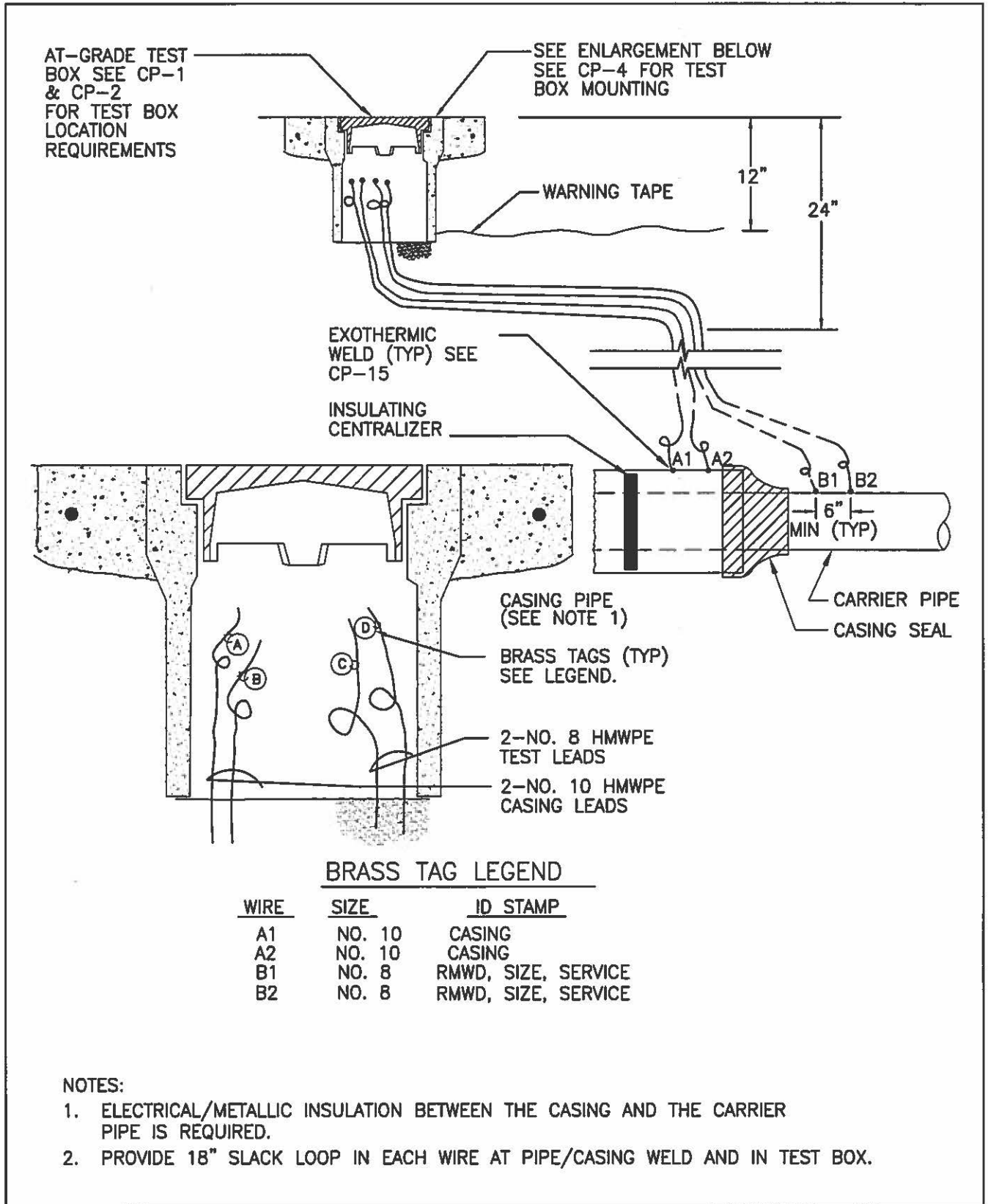

BRASS TAG LEGEND

WIRE	SIZE	ID STAMP
A1	NO. 10	CASING
A2	NO. 10	CASING
B1	NO. 8	RMWD, SIZE, SERVICE
B2	NO. 8	RMWD, SIZE, SERVICE

NOTES:

1. ELECTRICAL/METALLIC INSULATION BETWEEN THE CASING AND THE CARRIER PIPE IS REQUIRED.
2. PROVIDE 18" SLACK LOOP IN EACH WIRE AT PIPE/CASING WELD AND IN TEST BOX.



RAINBOW MUNICIPAL WATER DISTRICT

APPROVED: <i>[Signature]</i>		
RCE # 79790 EXP.09/30/2016		
REVISION	APPROVED	DATE

4-WIRE CASING TEST STATION

STANDARD DRAWING NO.
CP-7
JANUARY 2016

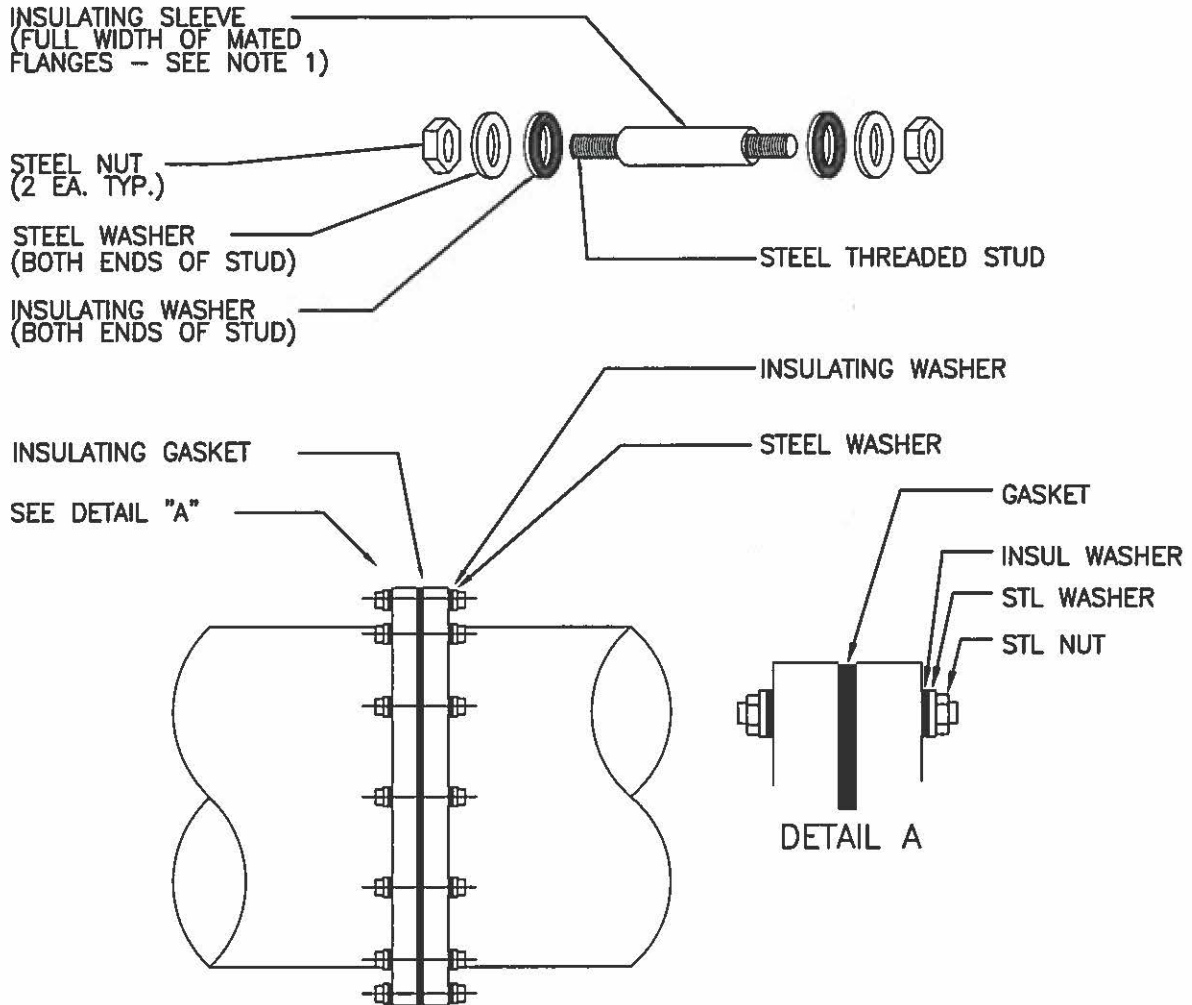

NOTES:

1. USE HALF WIDTH SLEEVES AT THREADED FLANGE BOLTS. (I.E. AT BFV BASE AND BONNET)
2. INSULATING MATERIALS:
 - GASKET - 16" OR GREATER - TYPE "E" FULLFACED PHENOLIC WITH RECTANGULAR NITRILE OR VITON O-RING SEAL.
 - LESS THAN 16" - TYPE "E" FULLFACED NEOPRENE FACED PHENOLIC.
 - SLEEVE -1/32-INCH THICK, FULL LENGTH TUBE, LAMINATED G-10 GLASS.
 - WASHER -1/8-INCH THICK LAMINATED G10 GLASS SHEET.
3. ALIGN FLANGE PROPERLY AND FOLLOW GASKET MANUFACTURER BOLT TIGHTENING SEQUENCE INSTRUCTIONS.
4. DO NOT PAINT OUTER SURFACE OF FLANGE WITH METALLIC PIGMENTED OR CONDUCTIVE PAINTS.
5. TEST MATED FLANGE WITH INSULATION CHECKER. THE FLANGE WILL BE ACCEPTED IF THERE IS NO INDICATION OF FULL OR PARTIAL SHORT.



RAINBOW MUNICIPAL WATER DISTRICT

APPROVED: <i>[Signature]</i>		
RCE # 79790 EXP.09/30/2016		
REVISION	APPROVED	DATE

ABOVE-GRADE
INSULATING FLANGE

STANDARD DRAWING NO.
CP-8
JANUARY 2016

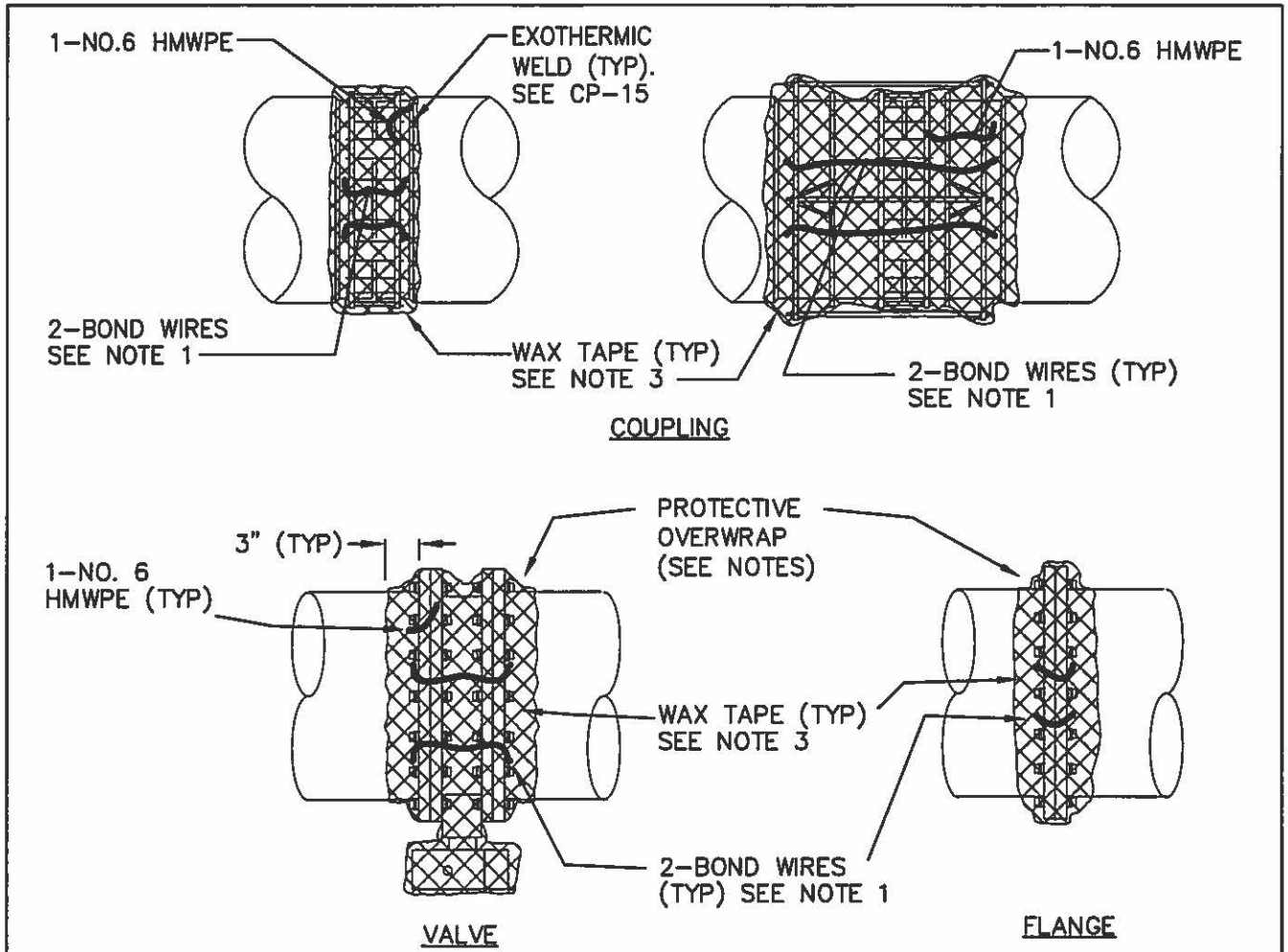

NOTES:

1. BOND WIRE SIZE:

PIPE DIA	SIZE
LESS THAN 12"	NO. 6 AWG HMWPE
12" THRU 18"	NO. 4 AWG HMWPE
GREATER THAN 18"	NO. 2 AWG HMWPE

2. WIRES CAN BE WELDED DIRECTLY TO PIPE OR FLANGE. JUMPER FROM PIPE TO VALVE OR FOLLOWER IS NO 6 HMWPE.
3. ALL NON-MORTAR COATED SURFACES SHALL BE WRAPPED WITH WAX TAPE. INDIVIDUALLY WRAP ALL RODS, BOLTS & IRREGULAR SURFACES. SEE SPEC SECT 13110.
4. INSTALL BOND WIRES BEFORE WAX TAPE.
5. CARE SHALL BE TAKEN WHEN BACKFILLING TRENCH TO PREVENT DAMAGE TO WAX TAPE SYSTEM.
6. FLANGES (ONLY) 18" AND LARGER SHALL BE OVERWRAPPED WITH 10 MIL PIPE TAPE (2 LAYERS 50% OVERLAP) TO PROTECT WAX TAPE DURING BACKFILLING.
7. FLANGES LESS THAN 18" REQUIRE NO PIPE TAPE PROTECTIVE OVERWRAP.



RAINBOW MUNICIPAL WATER DISTRICT

APPROVED: <i>[Signature]</i>		
RCE # 79790 EXP.09/30/2016		
REVISION	APPROVED	DATE

MECHANICAL JOINT BOND

STANDARD DRAWING NO.
CP-9
JANUARY 2016

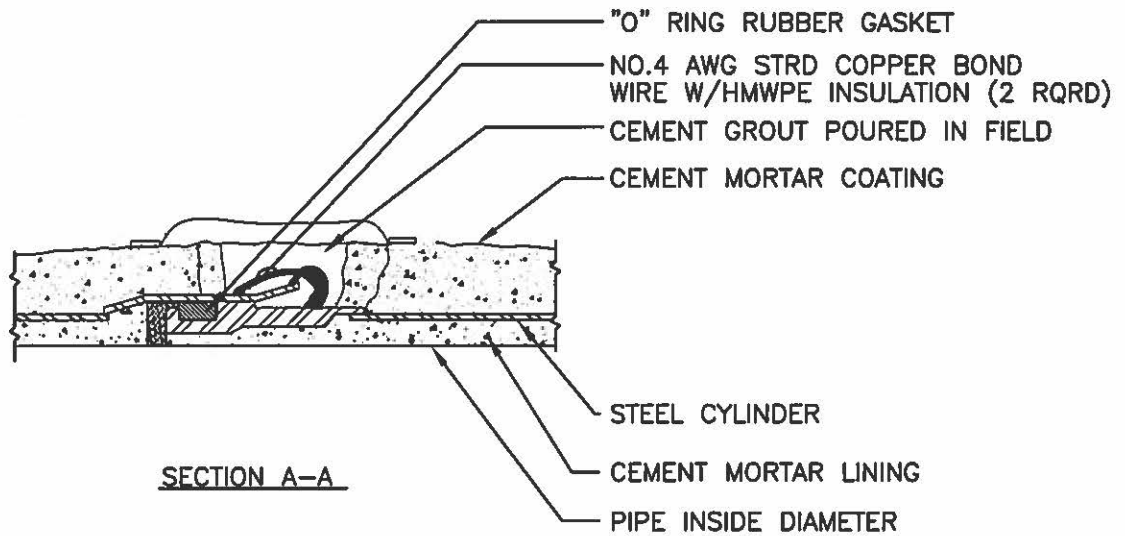
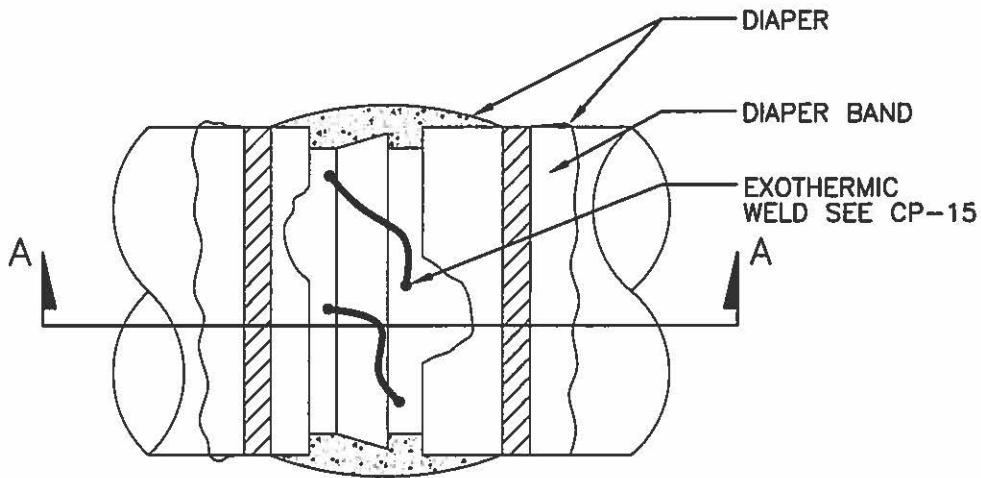

NOTES:

1. 2 BOND WIRES PER JOINT. SEE CP-9 FOR WIRE SIZE.
2. CHIP OUT MORTAR ONLY AS NECESSARY TO ALLOW WELD MOLD TO SET FLUSH ON CYLINDER OR BELL.
3. BOND WIRES TO BE AS SHORT AS PRACTICAL BUT NOT LESS THAN 6".



RAINBOW MUNICIPAL WATER DISTRICT

APPROVED: <i>[Signature]</i>		
RCE # 79790 EXP.09/30/2016		
REVISION	APPROVED	DATE

CML&C STEEL PIPE
JOINT BOND (WIRE JUMPER)

STANDARD DRAWING NO.
CP-10
JANUARY 2016

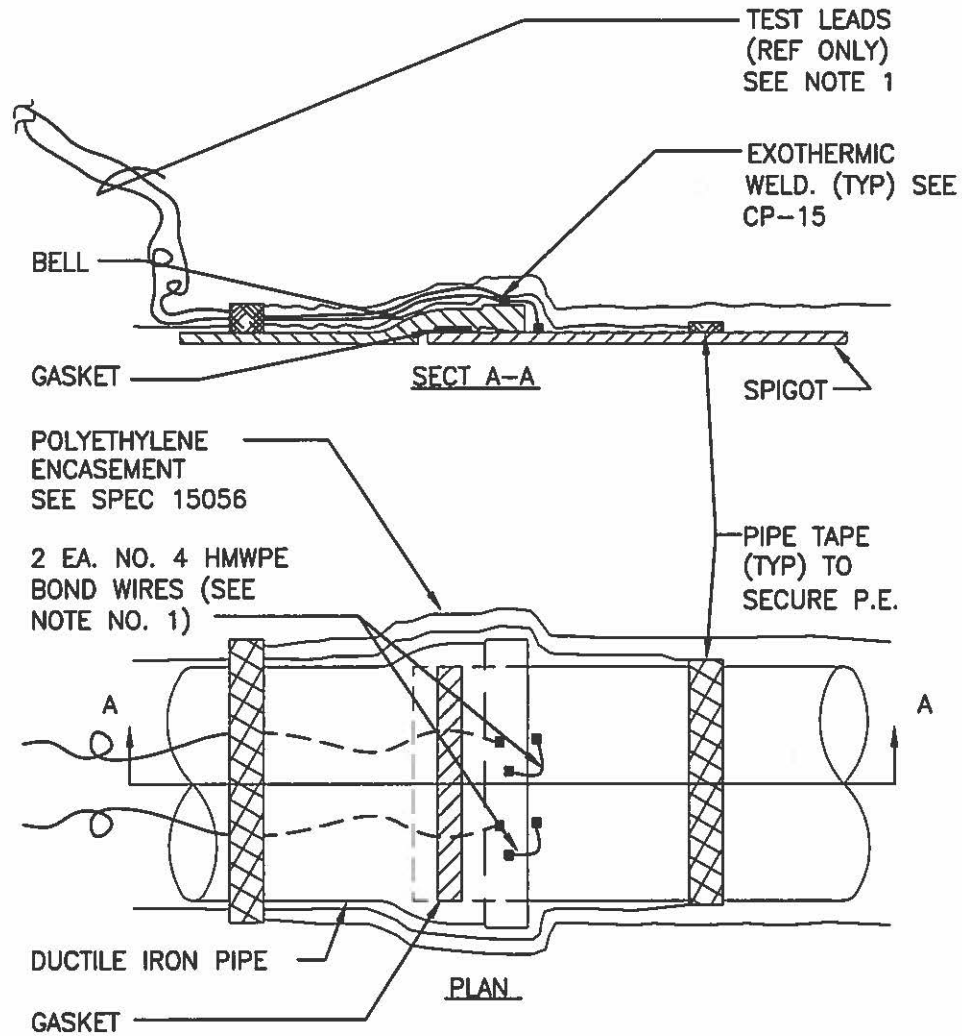

NOTES:

1. INSTALL BONDS AND TEST LEADS ONLY WHEN DIRECTED BY THE ENGINEER.
2. BOND WIRES SHALL BE OF MINIMUM LENGTH (6" MAX LENGTH) AND LAID FLUSH AGAINST PIPE AND UNDER P.E. ENCASEMENT.
3. TEST ALL WELDS BEFORE BACKFILLING. SEE CP-15.
4. WELDS ON BELL MUST BE MADE IN AN AREA BETWEEN THE END OF THE PIPE AND THE JOINT GASKET.
5. COAT WELDS PER CP-15.



RAINBOW MUNICIPAL WATER DISTRICT

APPROVED: <i>John P. Kunkel</i>		
RCE # 79790 EXP.09/30/2016		
REVISION	APPROVED	DATE

DIP JOINT BONDING
AND TEST LEAD CONNECTIONS

STANDARD DRAWING NO.
CP-11
JANUARY 2016

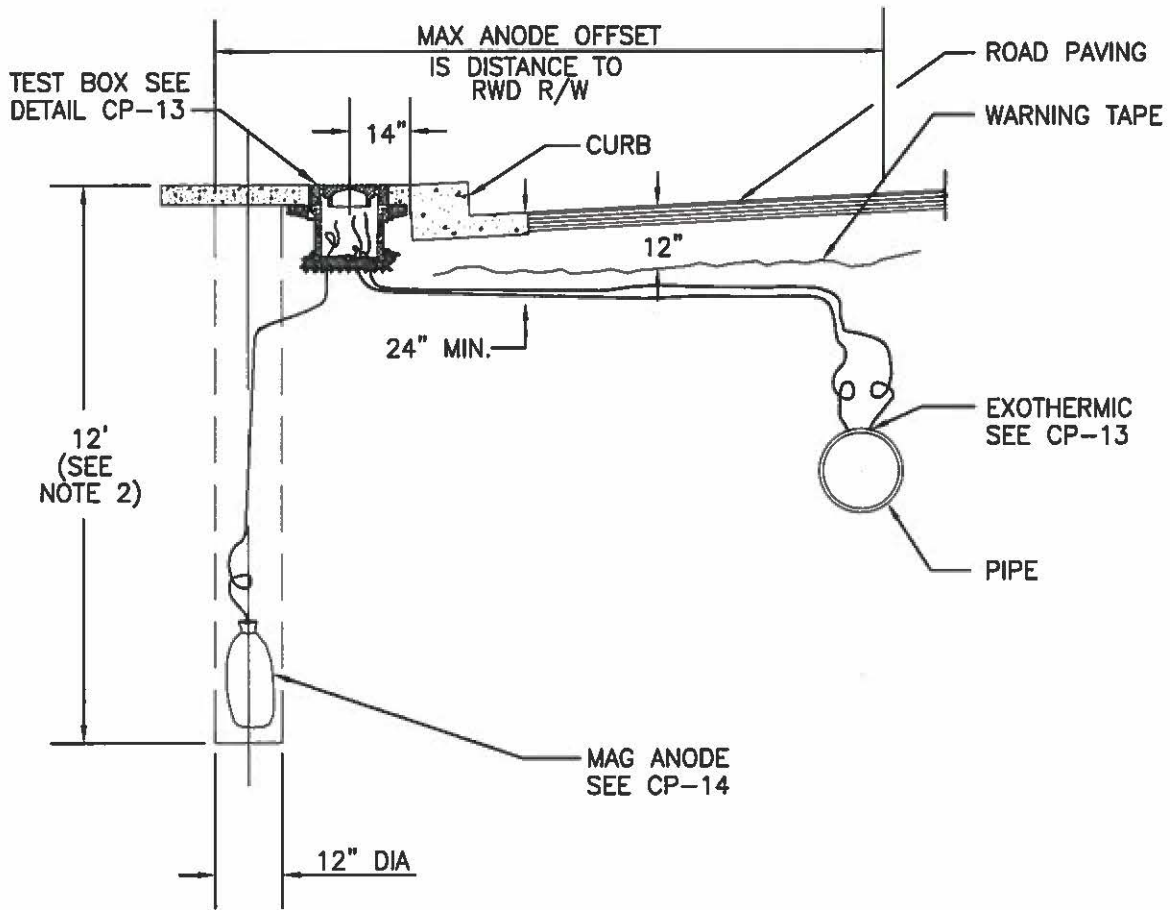

NOTES:

1. HORIZONTAL DISTANCES OFF PIPE SHALL BE MAXIMUM WITHIN RWD RIGHT-OF-WAY OR AS INDICATED IN PLAN DRAWINGS. DO NOT INSTALL ANODE SUCH THAT A FOREIGN METALLIC PIPELINE EXISTS BETWEEN ANODE AND PIPE.
2. DEPTH IS 12' UNLESS OTHERWISE INDICATED.
3. RELATIVE POSITION OF ANODE, PIPE AND TEST BOX CAN VARY FROM POSITION SHOWN. SEE CP DRAWINGS OR ENGINEER FOR SPECIFIC INSTALLATION REQUIREMENTS.



RAINBOW MUNICIPAL WATER DISTRICT

APPROVED: <i>[Signature]</i>		
RCE # 79790 EXP.09/30/2016		
REVISION	APPROVED	DATE

SINGLE ANODE
INSTALLATION

STANDARD DRAWING NO.
CP-12
JANUARY 2016

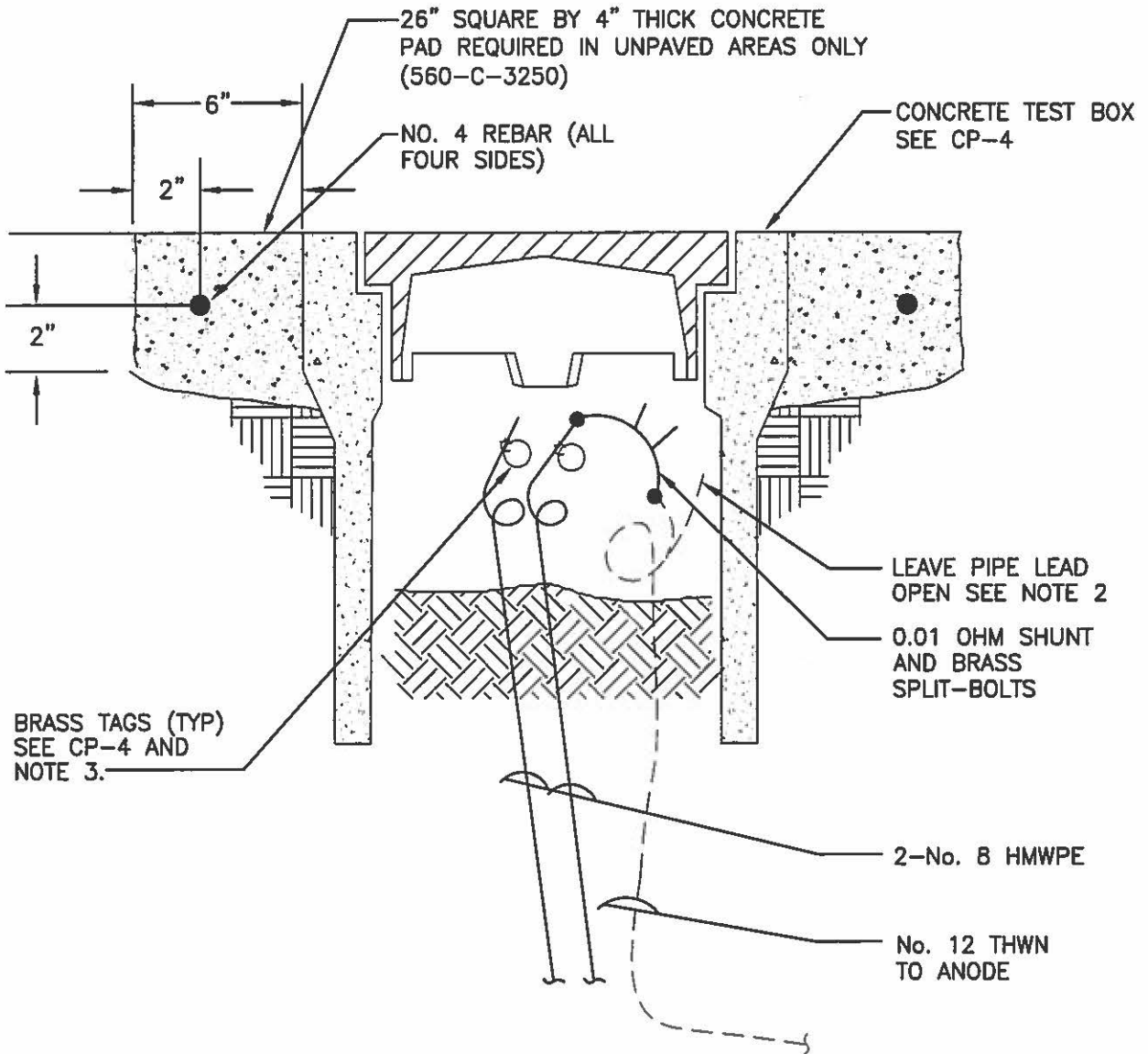

NOTES:

1. INSTALL TEST BOX AS SHOWN IN CP-1 AND CP-4.
2. CONTRACTOR TO PLACE ALL CONNECTION HARDWARE (SHUNTS & SPLIT BOLTS) IN TEST BOX, BUT MAKE UP TEST LEAD-TO-SHUNT CONNECTION ONLY. ATTACH SPLIT BOLT TO OTHER END OF SHUNT, BUT LEAVE ANODE LEAD OPEN. FINAL CONNECTION TO BE MADE AT SYSTEM ACTIVATION.
3. ANODE LEADS ARE NOT TAGGED.



RAINBOW MUNICIPAL WATER DISTRICT

APPROVED: <i>Shaft...</i>		
RCE # 79790 EXP.09/30/2016		
REVISION	APPROVED	DATE

SINGLE ANODE
TEST STATION WIRING

STANDARD DRAWING NO.
CP-13
JANUARY 2016

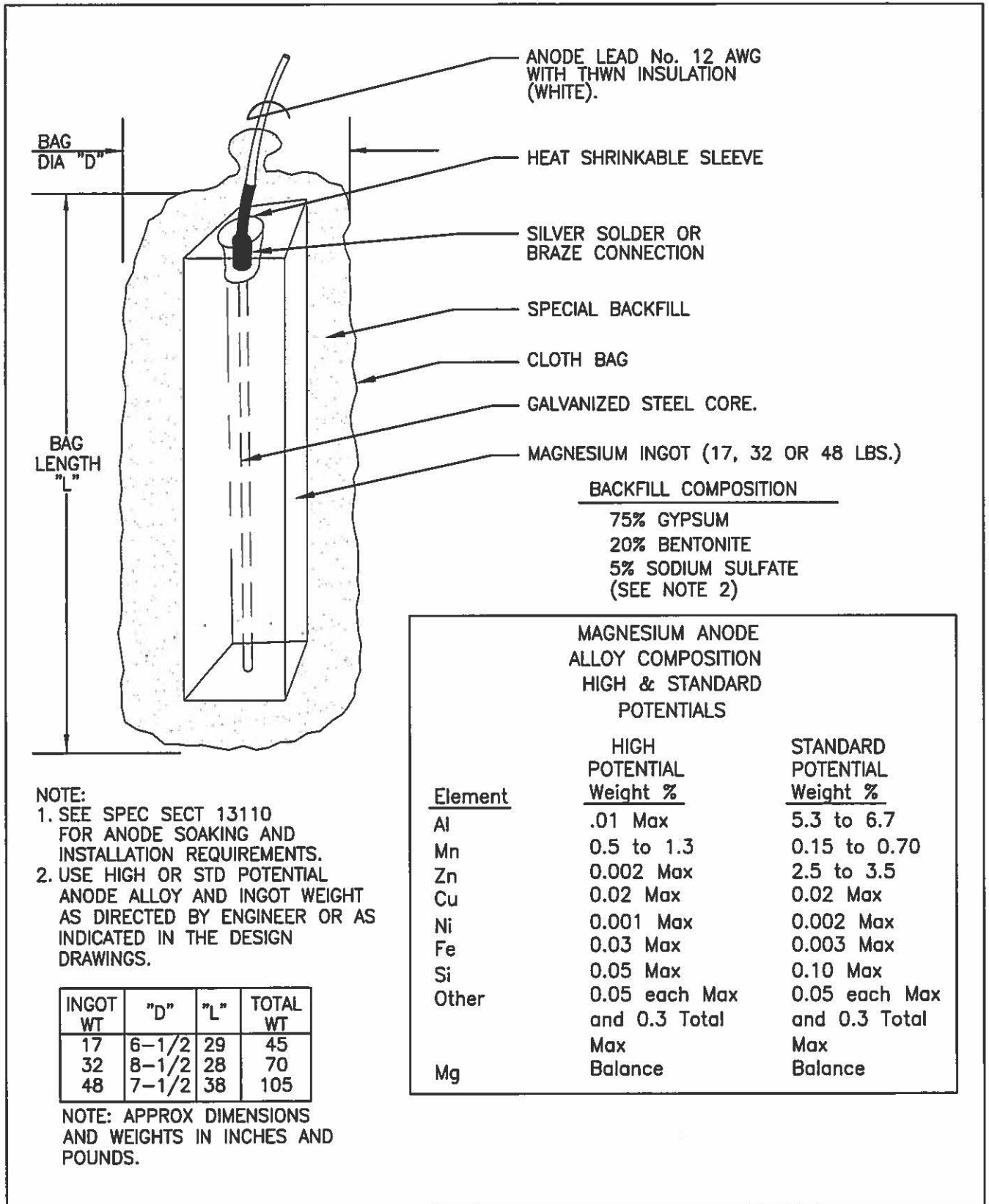

BACKFILL COMPOSITION

- 75% GYPSUM
- 20% BENTONITE
- 5% SODIUM SULFATE
- (SEE NOTE 2)

**MAGNESIUM ANODE
ALLOY COMPOSITION
HIGH & STANDARD
POTENTIALS**

Element	HIGH POTENTIAL Weight %	STANDARD POTENTIAL Weight %
Al	.01 Max	5.3 to 6.7
Mn	0.5 to 1.3	0.15 to 0.70
Zn	0.002 Max	2.5 to 3.5
Cu	0.02 Max	0.02 Max
Ni	0.001 Max	0.002 Max
Fe	0.03 Max	0.003 Max
Si	0.05 Max	0.10 Max
Other	0.05 each Max and 0.3 Total Max	0.05 each Max and 0.3 Total Max
Mg	Balance	Balance

NOTE:

1. SEE SPEC SECT 13110 FOR ANODE SOAKING AND INSTALLATION REQUIREMENTS.
2. USE HIGH OR STD POTENTIAL ANODE ALLOY AND INGOT WEIGHT AS DIRECTED BY ENGINEER OR AS INDICATED IN THE DESIGN DRAWINGS.

INGOT WT	"D"	"L"	TOTAL WT
17	6-1/2	29	45
32	8-1/2	28	70
48	7-1/2	38	105

NOTE: APPROX DIMENSIONS AND WEIGHTS IN INCHES AND POUNDS.



RAINBOW MUNICIPAL WATER DISTRICT

APPROVED: <i>[Signature]</i>		
RCE # 79790 EXP.09/30/2016		
REVISION	APPROVED	DATE

**PREPACKAGED MAGNESIUM
ANODE**

STANDARD DRAWING NO.
CP-14
JANUARY 2016

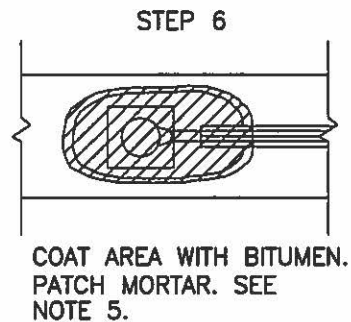
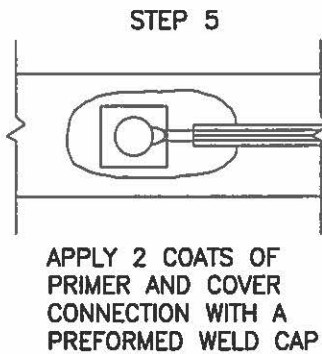
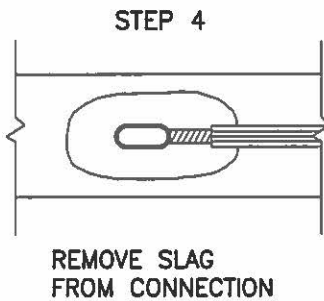
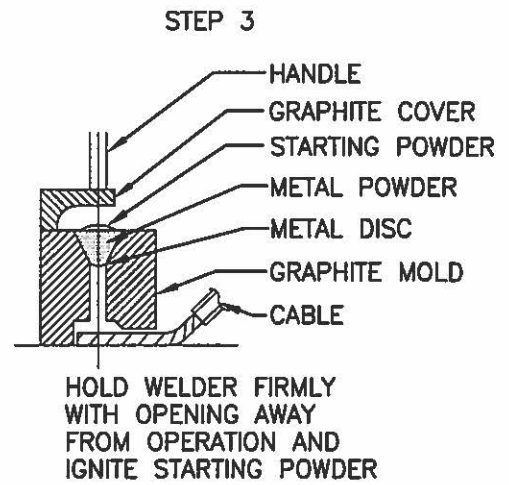
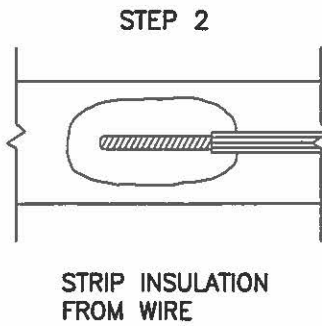
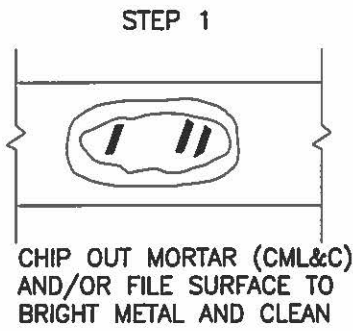

NOTES:

1. WELDER SHOWN IS FOR HORIZONTAL SURFACES. FOR VERTICAL SURFACES SIDE WELDER IS REQUIRED.
2. ALL WIRE WELDS SHALL BE 3 INCHES APART, MINIMUM.
3. STANDARD WELD CARTRIDGES SHALL BE USED FOR DUCTILE IRON AND STEEL SURFACE. FOR CAST IRON, USE XF-19 ALLOY OR EQUIVALENT.
4. TEST ALL WELDS BY STRIKING WITH 2 LBS. HAMMER. SEE SPEC SECTION 13110.
5. ALL EXPOSED METAL (STRUCTURE, WIRE & WELD) SHALL BE COVERED WITH 2 COATS OF PRIMER AND AN ELASTOMERIC WELD CAP.
6. APPLY GENEROUS COAT OF BITUMEN OVER WELD CAP AND EXPOSED METAL AREA UP TO EDGE OF MORTAR (CML&C) OR 3" BEYOND WELD CAP (DIP).
7. PATCH MORTAR COATING WITH QUICK SETTING MORTAR (CML&C).



RAINBOW MUNICIPAL WATER DISTRICT

APPROVED: <i>[Signature]</i>		
RCE # 79790 EXP.09/30/2016		
REVISION	APPROVED	DATE

EXOTHERMIC WELD

STANDARD DRAWING NO.
CP-15
JANUARY 2016

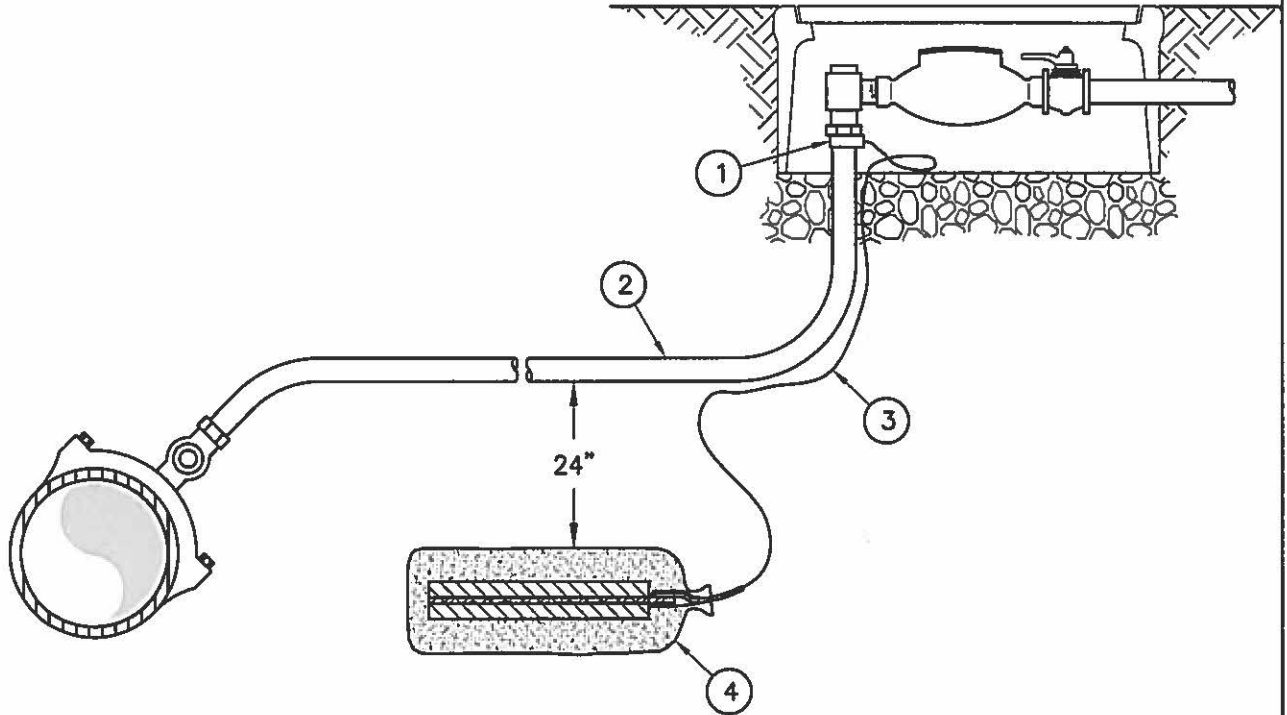

NOTES:

1. REFER TO SECTION 13110 OF THE SPECIFICATIONS.
2. WATER SERVICE SHOWN HEREON IS SHOWN AS AN EXAMPLE ONLY. ANODES SHALL BE INSTALLED ON ALL COPPER TUBING WHEN INDICATED ON THE APPROVED PLANS.
3. CLAMP ANODE LEAD WIRE TO COPPER TUBING AND SECURELY WRAP WITH DIELECTRIC TAPE.
4. LOCATE ANODE WITHIN THE PAVED ROADWAY APPROXIMATELY 5' - 10' FROM EDGE OF ROADWAY.
5. LOCATE ANODE WIRE WITHIN COPPER TUBING TRENCH. TWENTY-FOUR (24) INCHES OF EXCESS WIRE SHALL BE COILED ABOVE GROUND WITHIN METER BOX OR ENCLOSURE.
6. ANODE BACKFILL MATERIALS SHALL BE AS INDICATED IN SECTION 13110.
7. MATERIALS SHALL BE SELECTED FROM THE APPROVED MATERIALS LIST.

C W ——— |
 LEGEND ON PLANS

ITEM	NO.	DESCRIPTION	REMARKS
1	1	MECHANICAL GROUNDING CLAMP, SEE NOTE 3	
2	1	COPPER TUBING, SEE NOTE 2	
3	1	#12 AWG STRANDED COPPER WIRE WITH THW INSULATION, MINIMUM 25' LONG, SEE NOTE 5	
4	1	15-LBS MINIMUM PREPACKAGED ZINC ANODE, SEE NOTE 4	



RAINBOW MUNICIPAL WATER DISTRICT

APPROVED: <i>John P. Kiskipatid</i> RCE # 79790 EXP.09/30/2016 REVISION APPROVED DATE	NEW INSTALLATION OF SACRIFICIAL ANODES FOR COPPER TUBING	STANDARD DRAWING NO. CP-16 JANUARY 2016
---	---	--

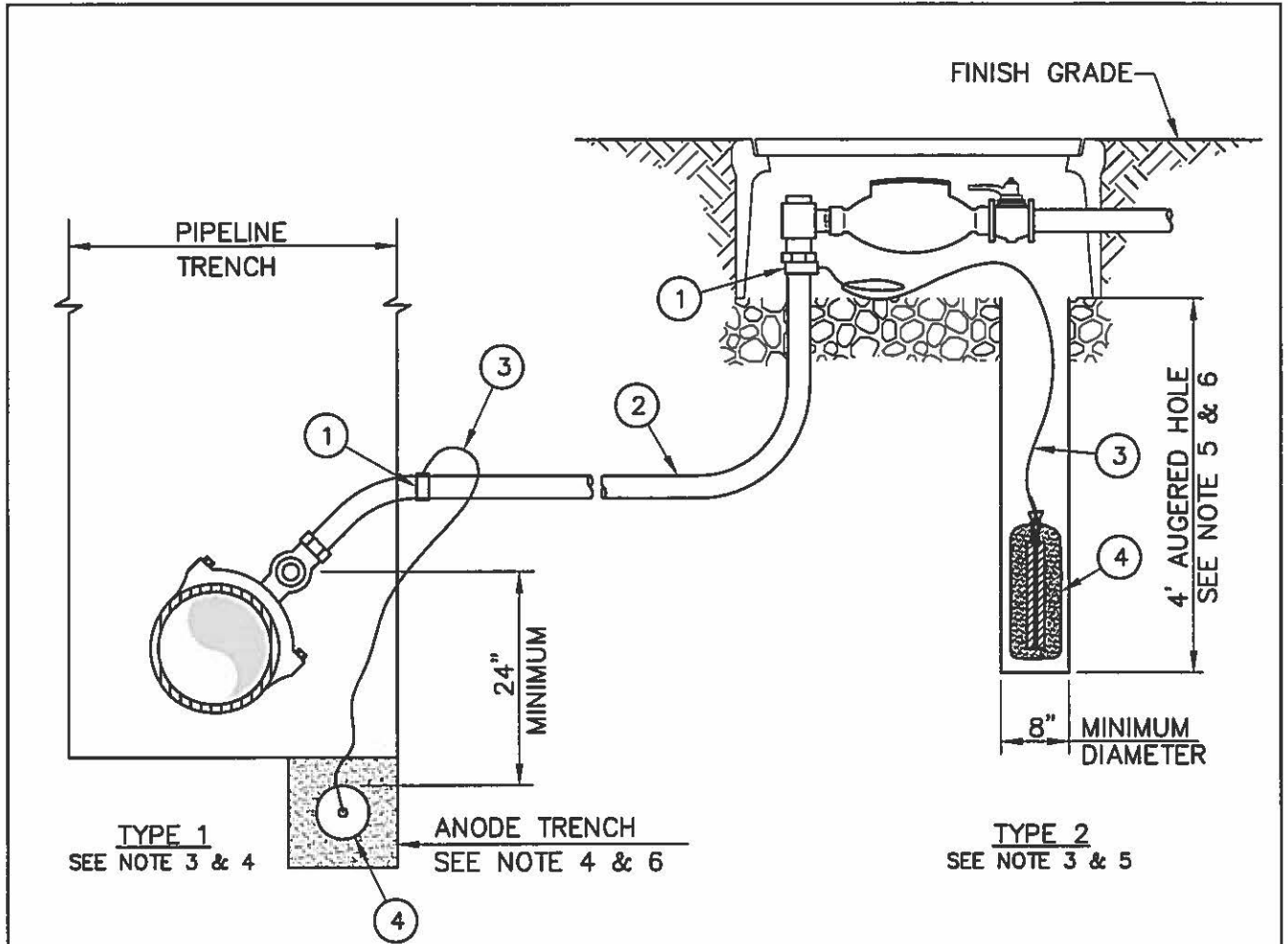

NOTES:

1. REFER TO SECTION 13110 OF THE SPECIFICATIONS.
2. WATER SERVICE SHOWN HEREON IS SHOWN AS AN EXAMPLE ONLY. ANODES SHALL BE INSTALLED ON ALL COPPER TUBING WHEN INDICATED ON THE APPROVED PLANS.
3. CLAMP ANODE LEAD WIRE TO COPPER TUBING AND SECURELY WRAP WITH DIELECTRIC TAPE.
4. FOR TYPE 1 INSTALLATION LOCATE ANODE WITHIN THE PIPELINE TRENCH UNDER THE CORPORATION STOP AS SHOWN ABOVE WITH WIRE SECURELY ATTACHED TO THE TUBING.
5. FOR TYPE 2 INSTALLATION LOCATE ANODE WITHIN AUGERED HOLE AS SHOWN ABOVE. TWENTY-FOUR (24) INCHES OF EXCESS WIRE SHALL BE COILED ABOVE GROUND WITHIN METER BOX OR ENCLOSURE.
6. ANODE BACKFILL MATERIALS SHALL BE AS INDICATED IN SECTION 13110.
7. MATERIALS SHALL BE SELECTED FROM THE APPROVED MATERIALS LIST.



ITEM	NO.	DESCRIPTION	REMARKS
1	1	MECHANICAL GROUNDING CLAMP, SEE NOTE 3	
2	1	EXISTING COPPER TUBING, SEE NOTE 2	
3	1	#12 AWG STRANDED COPPER WIRE WITH THW INSULATION, MINIMUM 25' LONG	
4	1	15-LBS MINIMUM PREPACKAGED ZINC ANODE,	



RAINBOW MUNICIPAL WATER DISTRICT

<p>APPROVED: <i>Shaft...</i></p> <p>RCE # 79790 EXP.09/30/2016</p> <table border="1"> <tr> <th>REVISION</th> <th>APPROVED</th> <th>DATE</th> </tr> <tr> <td> </td> <td> </td> <td> </td> </tr> </table>	REVISION	APPROVED	DATE				<p>RETROFIT INSTALLATION OF SACRIFICIAL ANODES FOR COPPER TUBING</p>	<p>STANDARD DRAWING NO.</p> <p style="text-align: center;">CP-17</p> <p style="text-align: center;">JANUARY 2016</p>
REVISION	APPROVED	DATE						

SANITARY SEWER FACILITIES

DRAWINGS

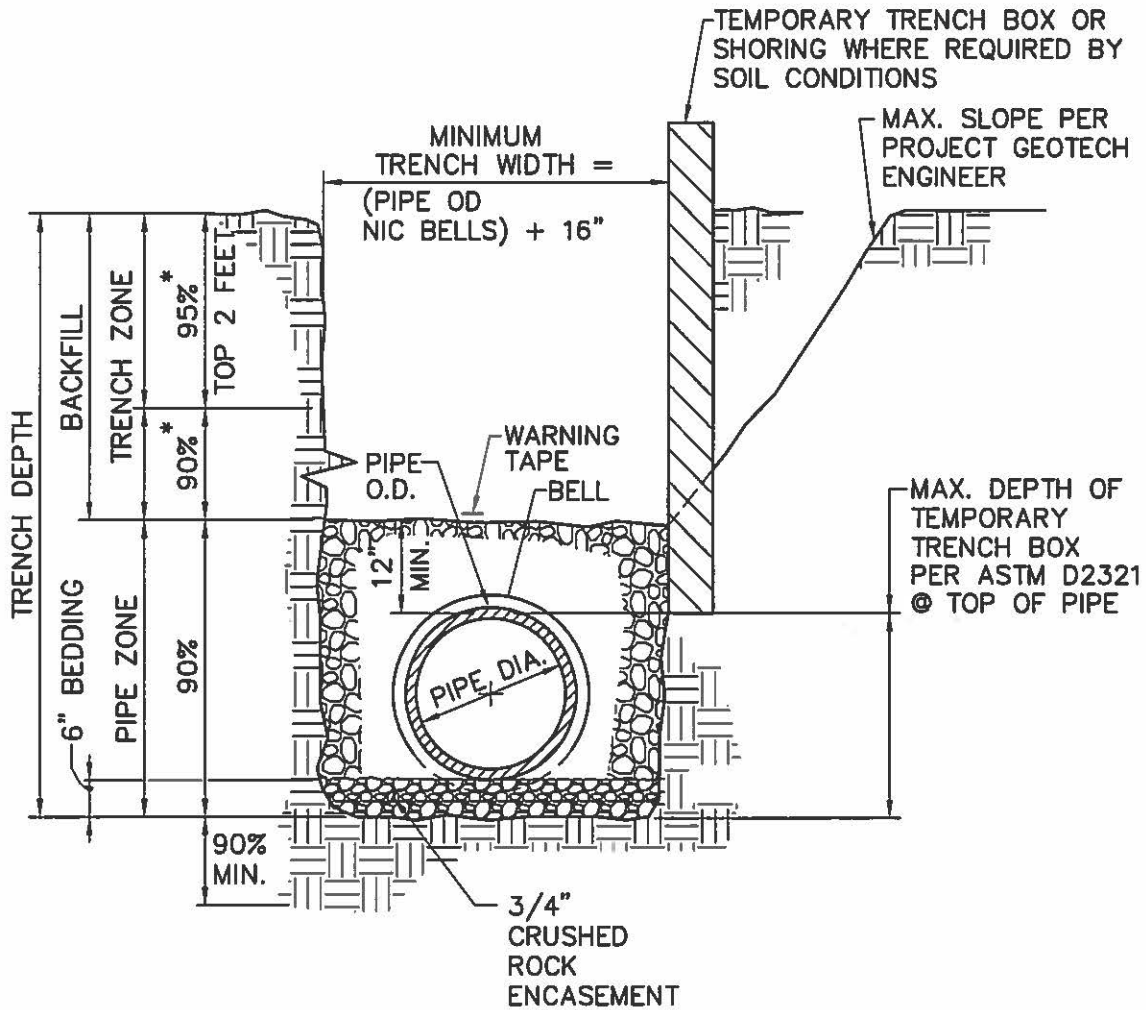

NOTES:

1. ALL PIPING SHALL BE INSTALLED IN ACCORDANCE W/ ASTM D2321 (STD PRACTICE FOR UG INSTALLATION OF PIPE FOR SEWERS & OTHER GRAVITY-FLOW APPLICATIONS.)
2. FOR TRENCHING IN IMPROVED STREETS, RESTORE PAVEMENT TO THE JURISDICTIONAL AGENCY'S STANDARDS.
3. (*) INDICATES MINIMUM RELATIVE COMPACTION. RELATIVE COMPACTION UNDER STREETS SHALL BE IN ACCORDANCE WITH LOCAL CITY OR JURISDICTIONAL REQUIREMENTS.



RAINBOW MUNICIPAL WATER DISTRICT

APPROVED:

John P. [Signature]

RCE # 79790 EXP.09/30/2016

REVISION	APPROVED	DATE

STANDARD PIPE ZONE AND TRENCH BACKFILL

STANDARD DRAWING NO.

S-1

JANUARY 2016

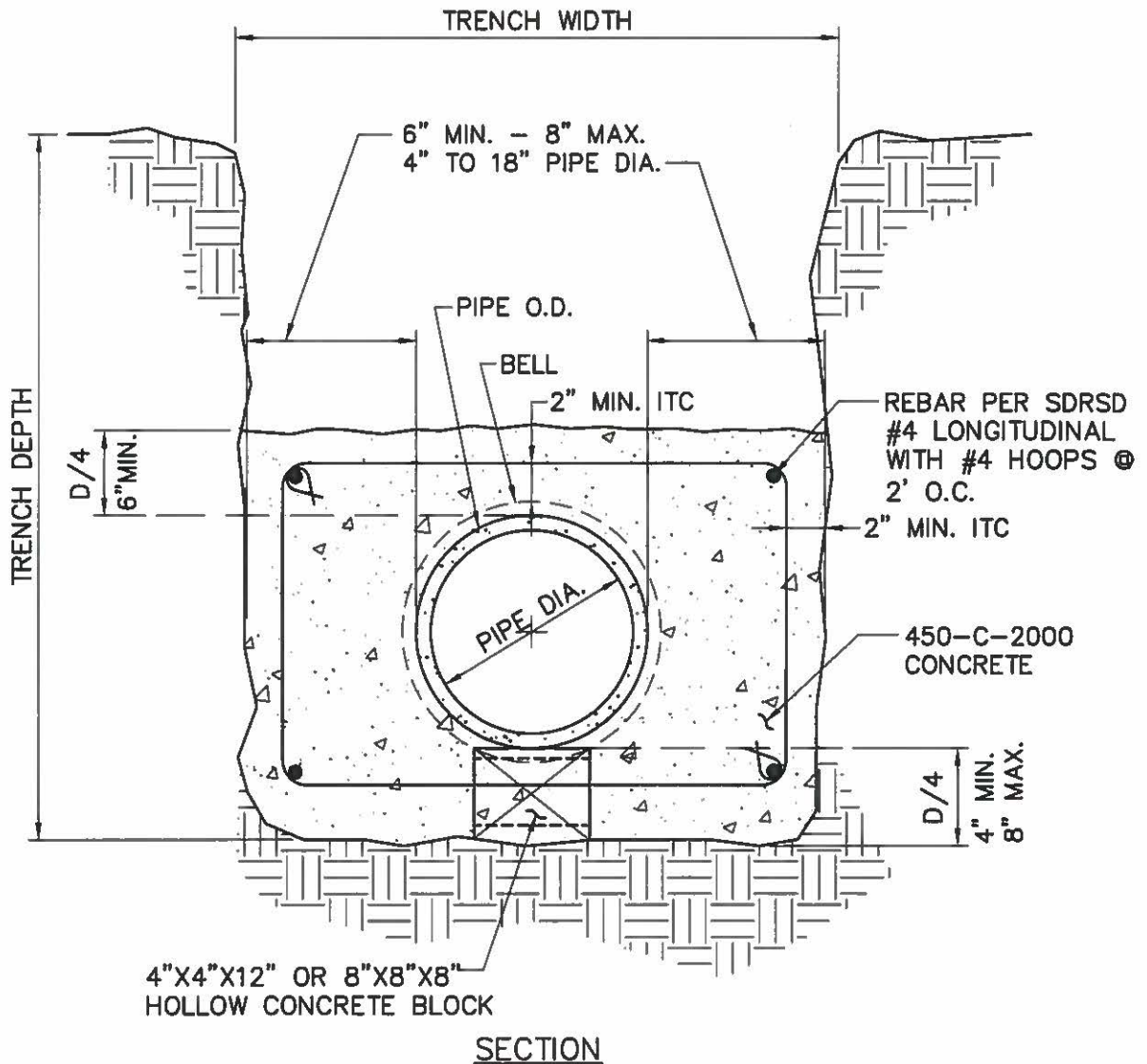

NOTE:
ENCASE PIPE TO NEAREST
FLEXIBLE JOINT



LEGEND ON PLANS



RAINBOW MUNICIPAL WATER DISTRICT

APPROVED:		
<i>Sheela Patel</i>		
RCE # 79790 EXP.09/30/2016		
REVISION	APPROVED	DATE

CONCRETE ENCASEMENT

STANDARD DRAWING NO.
S-2
JANUARY 2016

WATER & SEWER MAINS SHALL BE INSTALLED IN SEPARATE TRENCHES. SEWERS SHALL BE INSTALLED AT LEAST 10- FEET HORIZONTALLY FROM EXISTING OR NEW WATER MAINS.

PARALLEL CONSTRUCTION

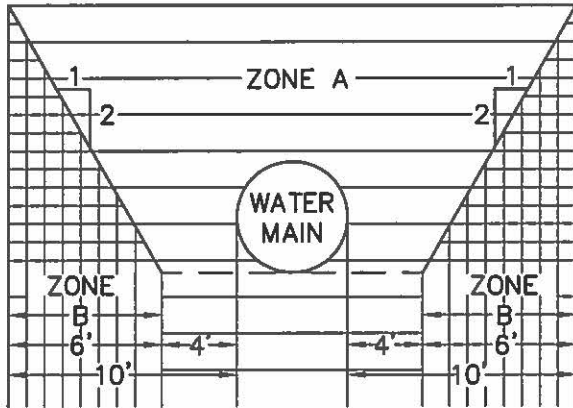

PERPENDICULAR CONSTRUCTION

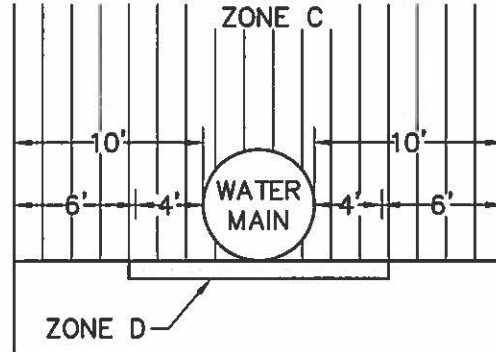

NOTES: DIMENSIONS ARE FROM OUTSIDE OF WATER MAIN TO OUTSIDE OF SEWER

SANITARY SEWERS ARE NOT PERMITTED WITHIN ANY OF THE ABOVE INDICATED ZONES UNLESS CONSTRUCTED IN CONFORMANCE WITH THE SPECIAL REQUIREMENTS AS SHOWN BELOW.

ZONE	SPECIAL SEWER CONSTRUCTION REQUIREMENTS
------	---

	SEWER LINES WILL NOT BE PERMITTED IN THIS ZONE WITHOUT SPECIAL WRITTEN PERMISSION FROM THE DEPARTMENT OF HEALTH.
--	--

	RUBBER GASKETED PLASTIC PIPE.
--	-------------------------------

	CONCRETE ENCASED SEWER PIPE; OR ANY SEWER PIPE WITHIN A CONTINUOUS STEEL CASING, WHICH CASING SHALL HAVE A THICKNESS OF NOT LESS THAN ONE-FOURTH INCH AND WITH ALL VOIDS BETWEEN SEWER PIPE AND CASING PRESSURE GROUTED WITH SAND CEMENT GROUT.



RAINBOW MUNICIPAL WATER DISTRICT

APPROVED: <i>John P. Kistner</i>		
RCE # 79790 EXP.09/30/2016		
REVISION	APPROVED	DATE

PIPELINE SEPARATION REQUIREMENTS

STANDARD DRAWING NO.
S-3
JANUARY 2016

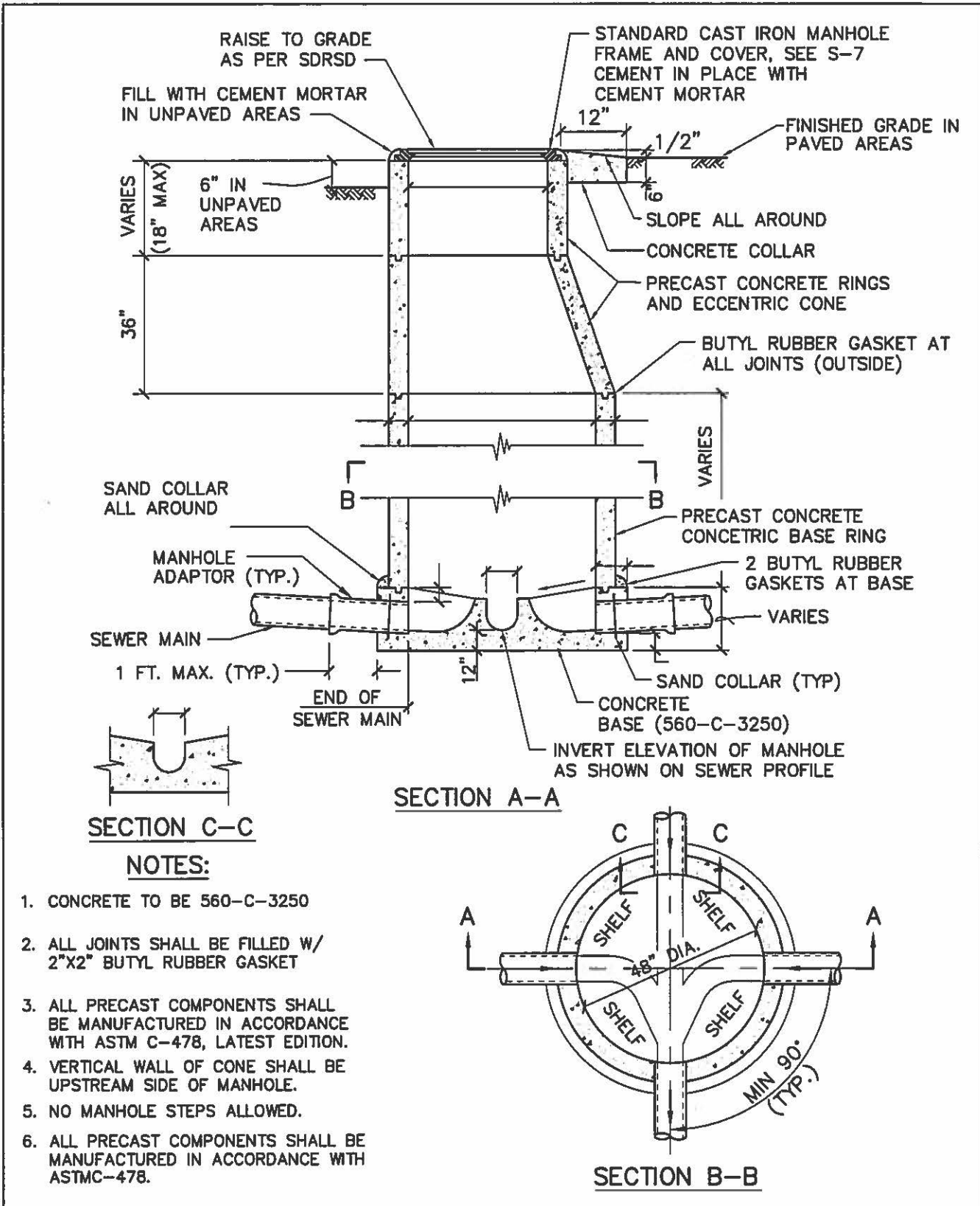

SECTION C-C

SECTION A-A

SECTION B-B

NOTES:

1. CONCRETE TO BE 560-C-3250
2. ALL JOINTS SHALL BE FILLED W/ 2"X2" BUTYL RUBBER GASKET
3. ALL PRECAST COMPONENTS SHALL BE MANUFACTURED IN ACCORDANCE WITH ASTM C-478, LATEST EDITION.
4. VERTICAL WALL OF CONE SHALL BE UPSTREAM SIDE OF MANHOLE.
5. NO MANHOLE STEPS ALLOWED.
6. ALL PRECAST COMPONENTS SHALL BE MANUFACTURED IN ACCORDANCE WITH ASTM C-478.



RAINBOW MUNICIPAL WATER DISTRICT

APPROVED: <i>[Signature]</i>		
RCE # 79790 EXP.09/30/2016		
REVISION	APPROVED	DATE

**STANDARD PRECAST CONCRETE
MANHOLE (4' DIA.)**

STANDARD DRAWING NO.
S-4
JANUARY 2016

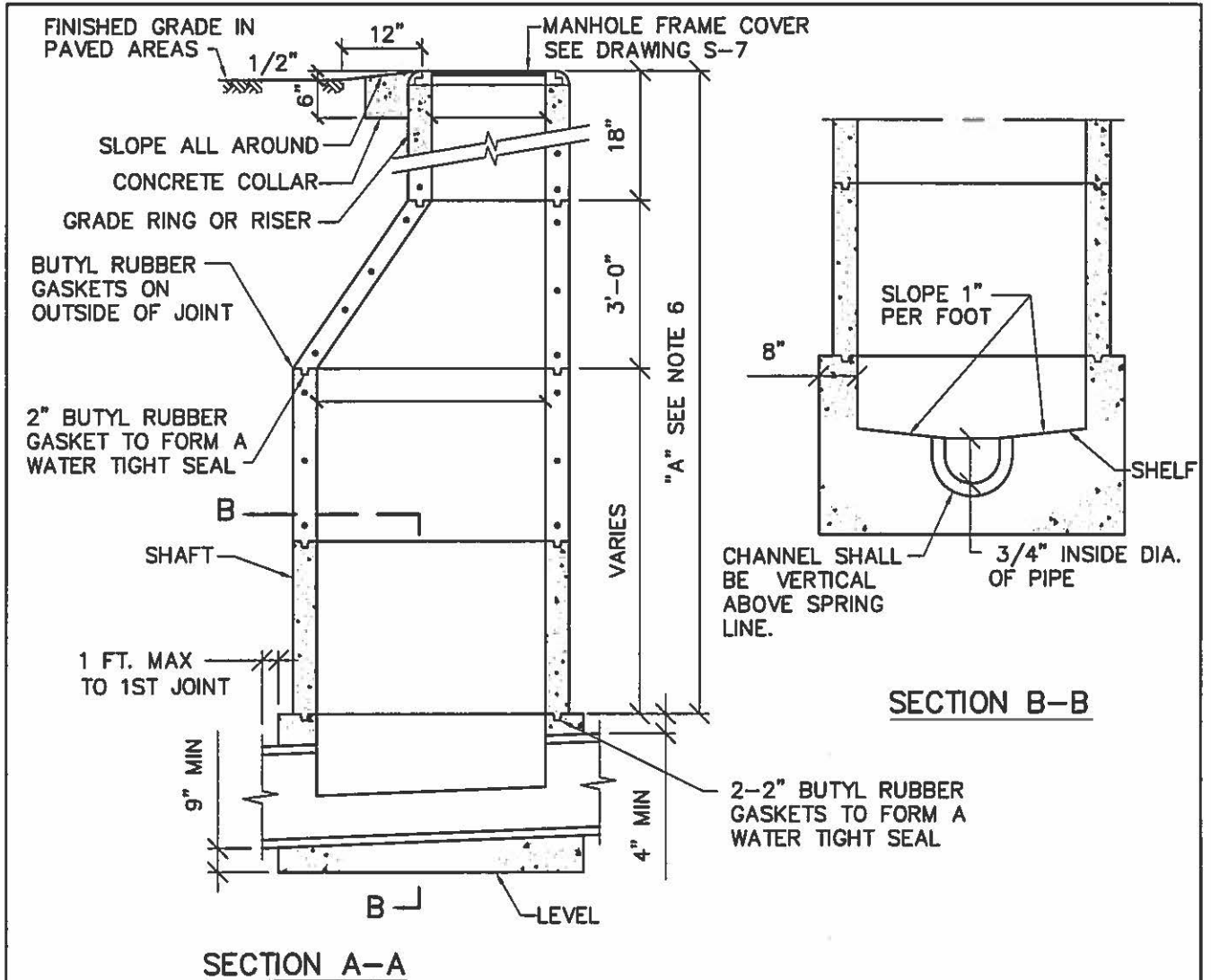

NOTES:

1. MANHOLE FRAME SHALL BE SET IN CLASS "C" MORTAR.
2. ALL PRECAST COMPONENTS SHALL BE MANUFACTURED IN ACCORDANCE WITH ASTM C-478.
3. VERTICAL WALL OF CONE SHALL BE ON THE UPSTREAM SIDE OF THE MANHOLE.
4. CONCRETE BASE SHALL BE 560-C-3250.
5. "SAND COLLAR" MH ADAPTORS SHALL BE PROVIDED FOR ALL MH CONNECTIONS.
6. PRECAST SECTIONS SHALL BE USED WITHIN DIMENSION "A" AS REQUIRED, IN ORDER OF PREFERENCE LISTED:
 - A. CONE (NOTCHED FOR PIPE IF DIMENSION "A" IS LESS THEN 3').
 - B. 6" TO 18" OF 3' DIAMETER GRADE RINGS/AND/OR RISERS.
 - C. 5' DIAMETER SHAFT VARIABLE HEIGHT.
7. ALL PATCHING WITHIN MANHOLE BASE SHALL BE EPOXY MORTAR.
8. PRIOR APPROVAL OF PRECAST BASE IS REQUIRED BY THE DISTRICT ENGINEER.
9. MAXIMUM ALLOWABLE CHANGE OF DIRECTION AT MH = 45°.
10. PROVIDE SPECIFIC DETAIL FOR REVIEW AND APPROVAL BY DISTRICT ENGINEER FOR MH'S W/ MORE THAN ONE INLET OR OUTLET, 18" OR LARGER.



RAINBOW MUNICIPAL WATER DISTRICT

APPROVED: <i>[Signature]</i>		
RCE # 79790 EXP.09/30/2016		
REVISION	APPROVED	DATE

STANDARD PRECAST CONCRETE MANHOLE (5' DIA.)

STANDARD DRAWING NO.
S-5
JANUARY 2016

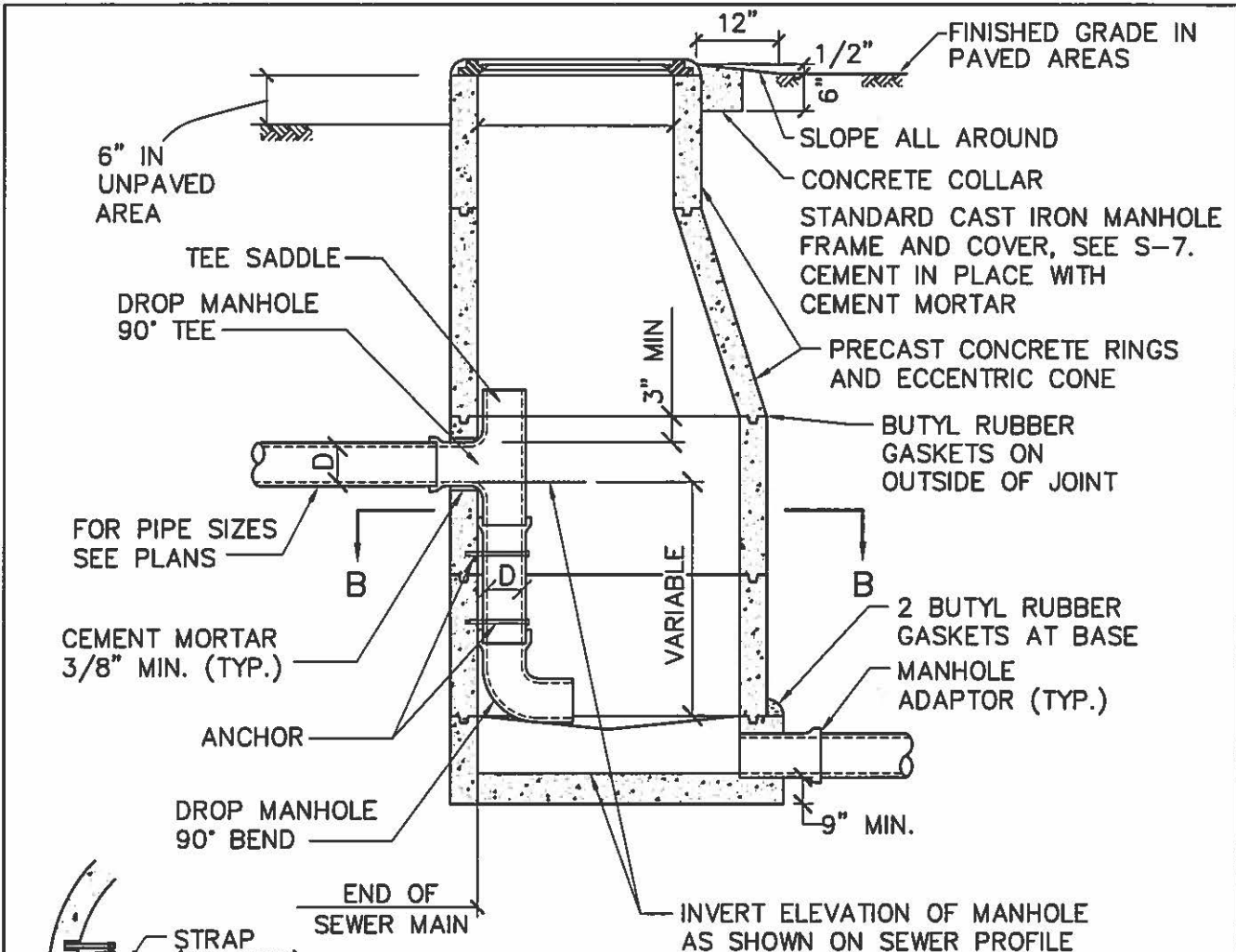

SECTION A-A

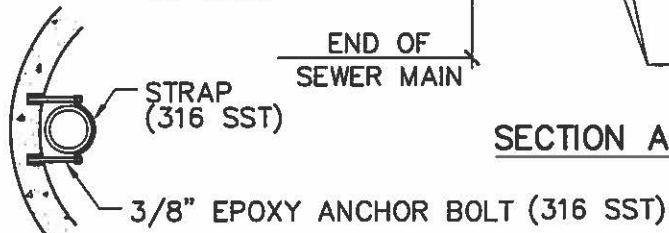

ANCHOR DETAIL

NOTES: DROP MANHOLES ALLOWED ONLY WITH APPROVAL OF THE DE

1. DROP MANHOLE SHALL BE IDENTICAL TO STANDARD CONCRETE MANHOLE, EXCEPT FOR PIPE DETAILS AS SHOWN.
2. THE DROP MANHOLE TEE SHALL ENTER THE 5' DIA. RING
3. CLEAN AND ROUGHEN OUTSIDE SURFACE OF RINGS AND APPLY NEAT CEMENT PAST PRIOR TO POURING SUPPORT FOR DROP SECTION.
4. NO MANHOLE STEPS ALLOWED.

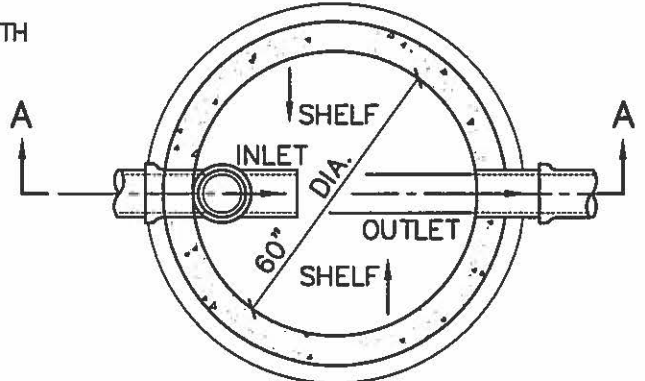

SECTION B-B



RAINBOW MUNICIPAL WATER DISTRICT

APPROVED: <i>Shay P. K... ..</i>		
RCE # 79790 EXP.09/30/2016		
REVISION	APPROVED	DATE

STANDARD PRECAST CONCRETE INSIDE DROP MANHOLE

STANDARD DRAWING NO.
S-6
JANUARY 2016

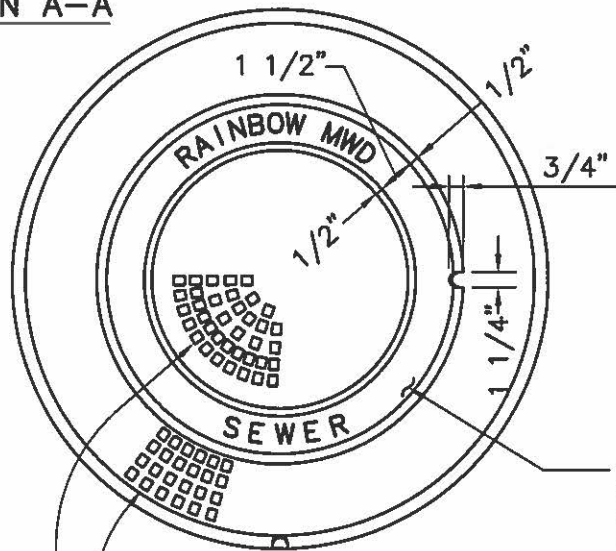
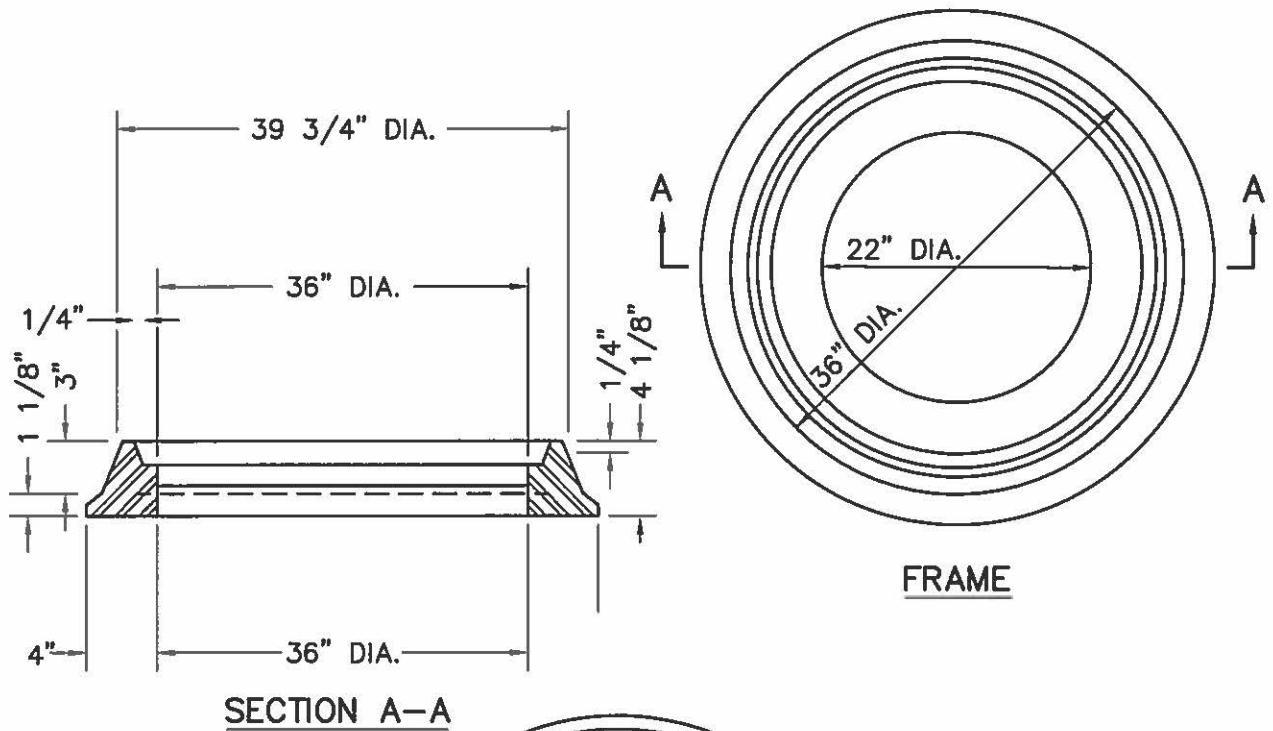

NOTE:

1. LOCKING FRAMES AND COVERS ARE REQUIRED IN REMOTE AREAS OR AS DETERMINED BY THE D.E.



RAINBOW MUNICIPAL WATER DISTRICT

APPROVED: <i>Shafiqul Kabir</i>		
RCE # 79790 EXP.09/30/2016		
REVISION	APPROVED	DATE

36" MANHOLE FRAME AND TWO CONCENTRIC COVERS

STANDARD DRAWING NO.
S-7
JANUARY 2016

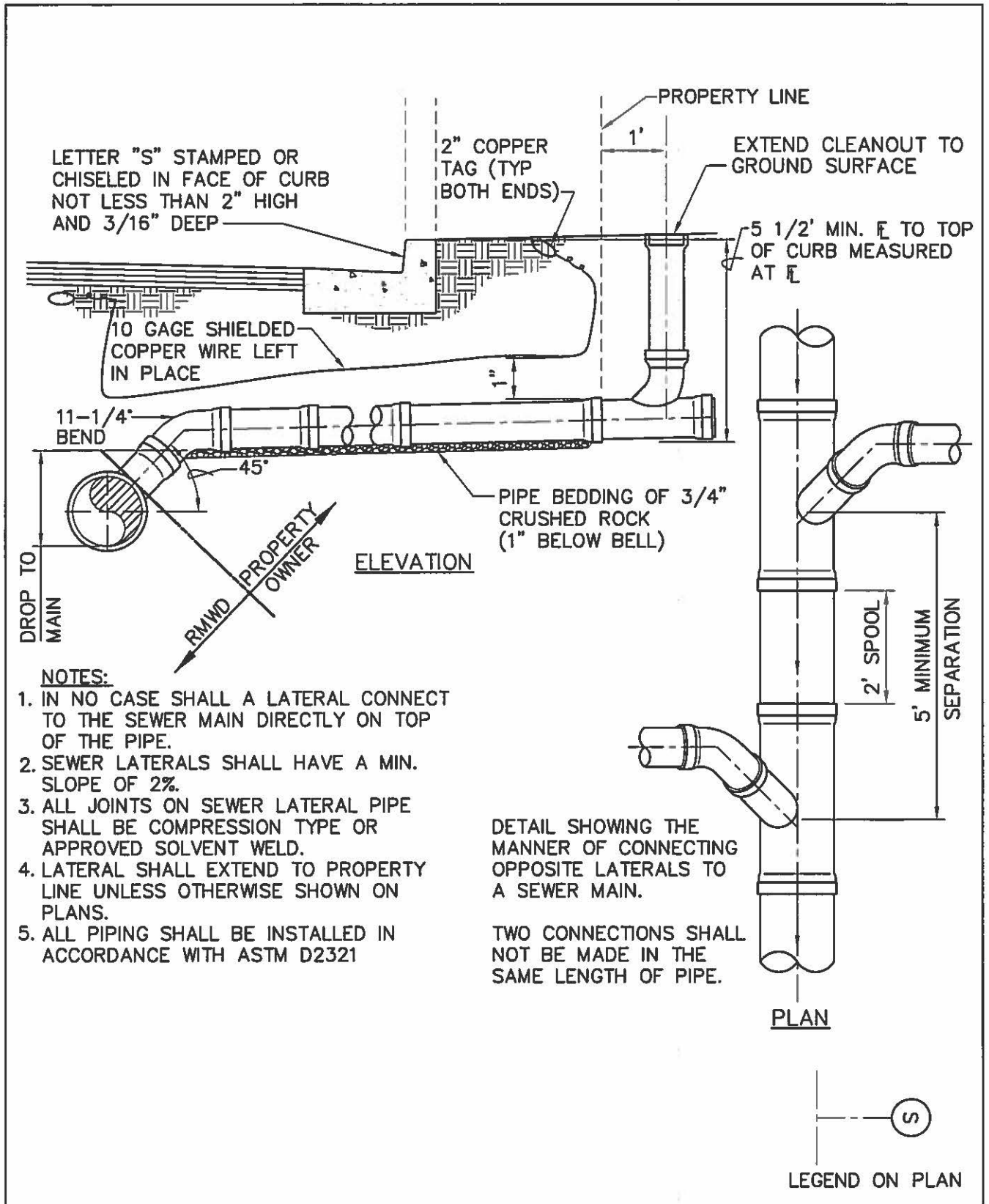

RAINBOW MUNICIPAL WATER DISTRICT

APPROVED: *Shirley K. Kunkel*

RCE # 79790 EXP. 09/30/2016

REVISION	APPROVED	DATE

NEW INSTALLATION
PVC SEWER LATERAL

STANDARD DRAWING NO.
S-8
JANUARY 2016

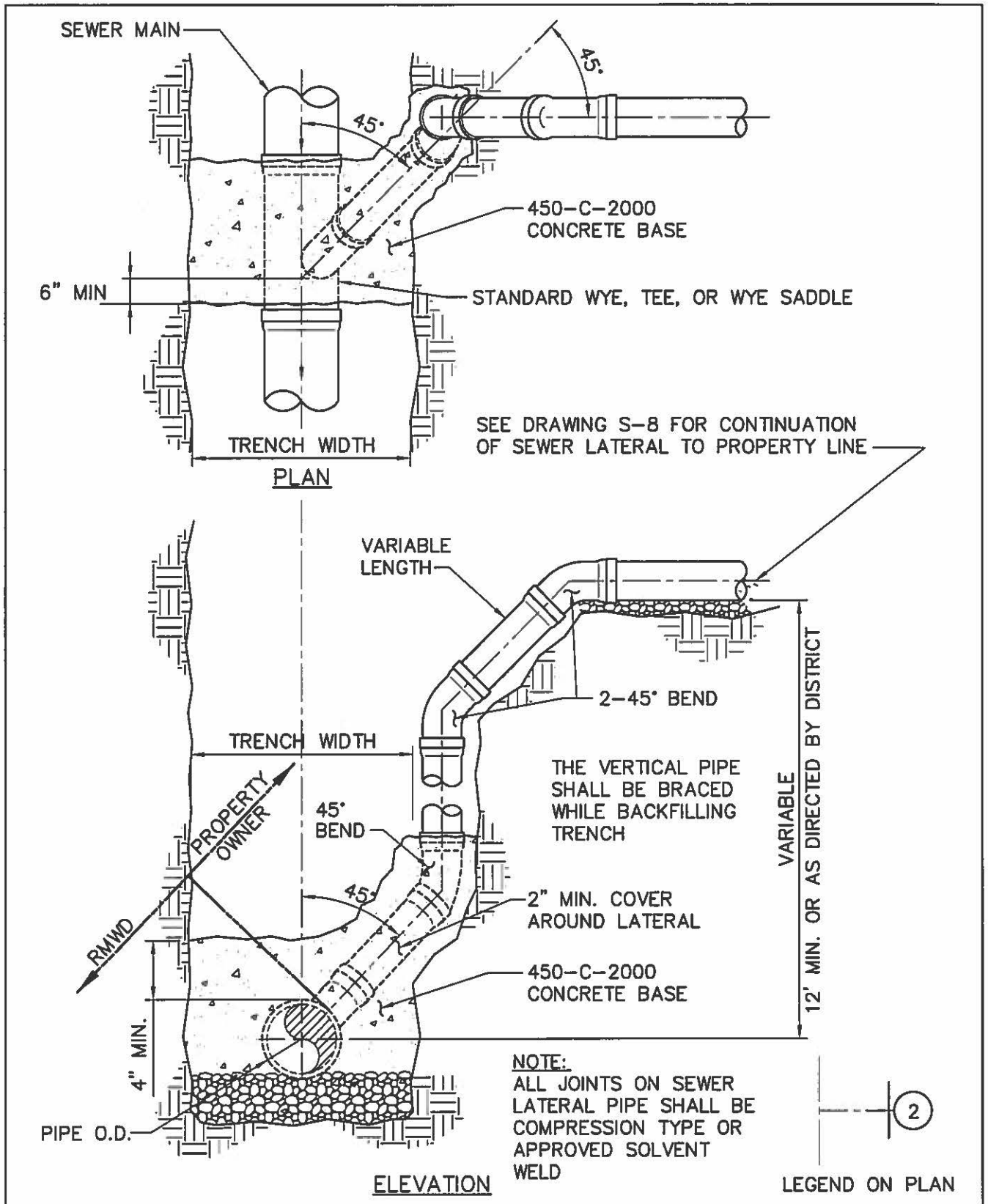

RAINBOW MUNICIPAL WATER DISTRICT

APPROVED: *[Signature]*

RCE # 79790 EXP.09/30/2016

REVISION	APPROVED	DATE

DEEP CUT SEWER LATERAL

STANDARD DRAWING NO.
S-9
JANUARY 2016

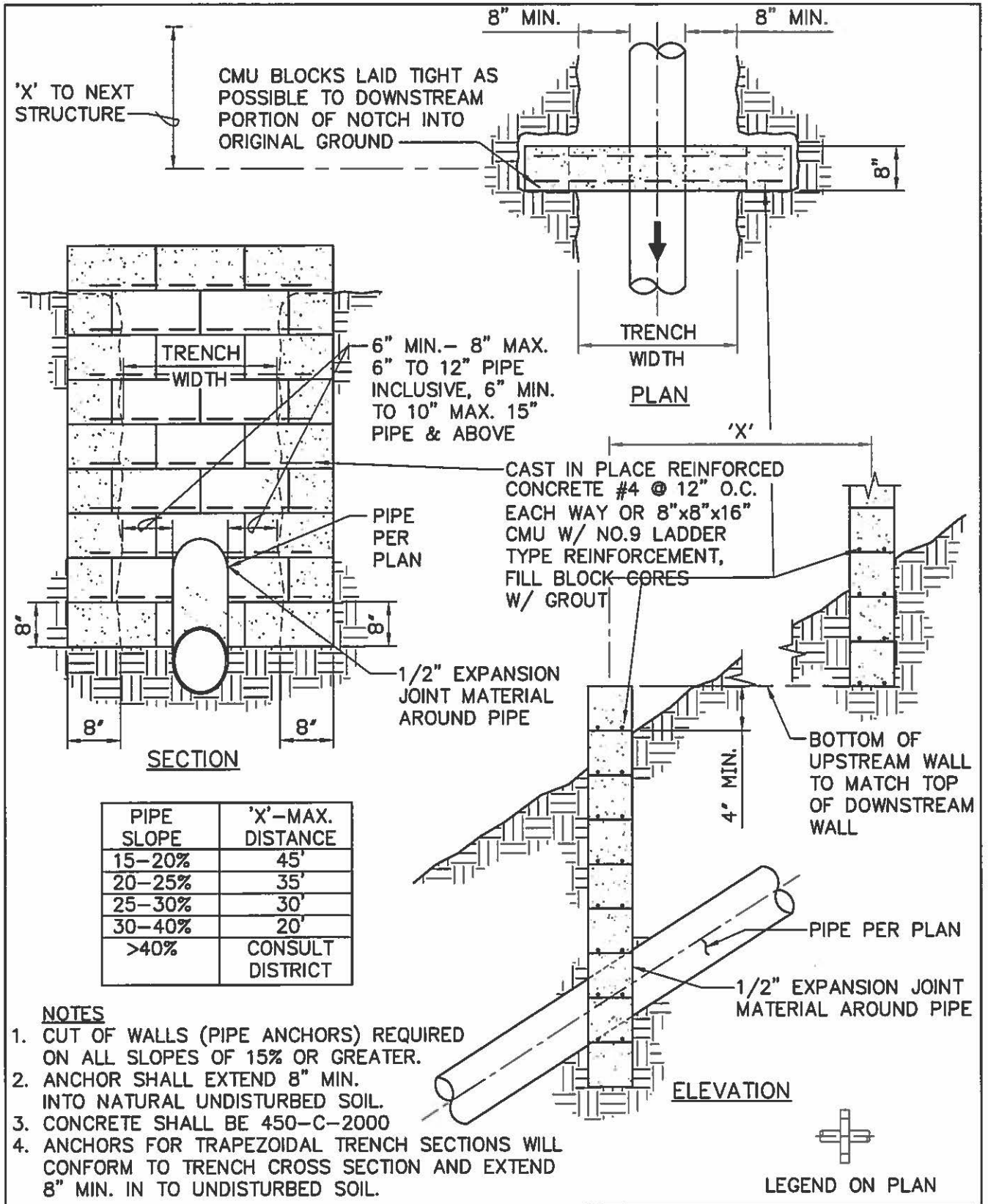

RAINBOW MUNICIPAL WATER DISTRICT

APPROVED: *[Signature]*

RCE # 79790 EXP.09/30/2016

REVISION	APPROVED	DATE

STANDARD CUTOFF WALL FOR NON PAVED AREA

STANDARD DRAWING NO.
S-10
JANUARY 2016

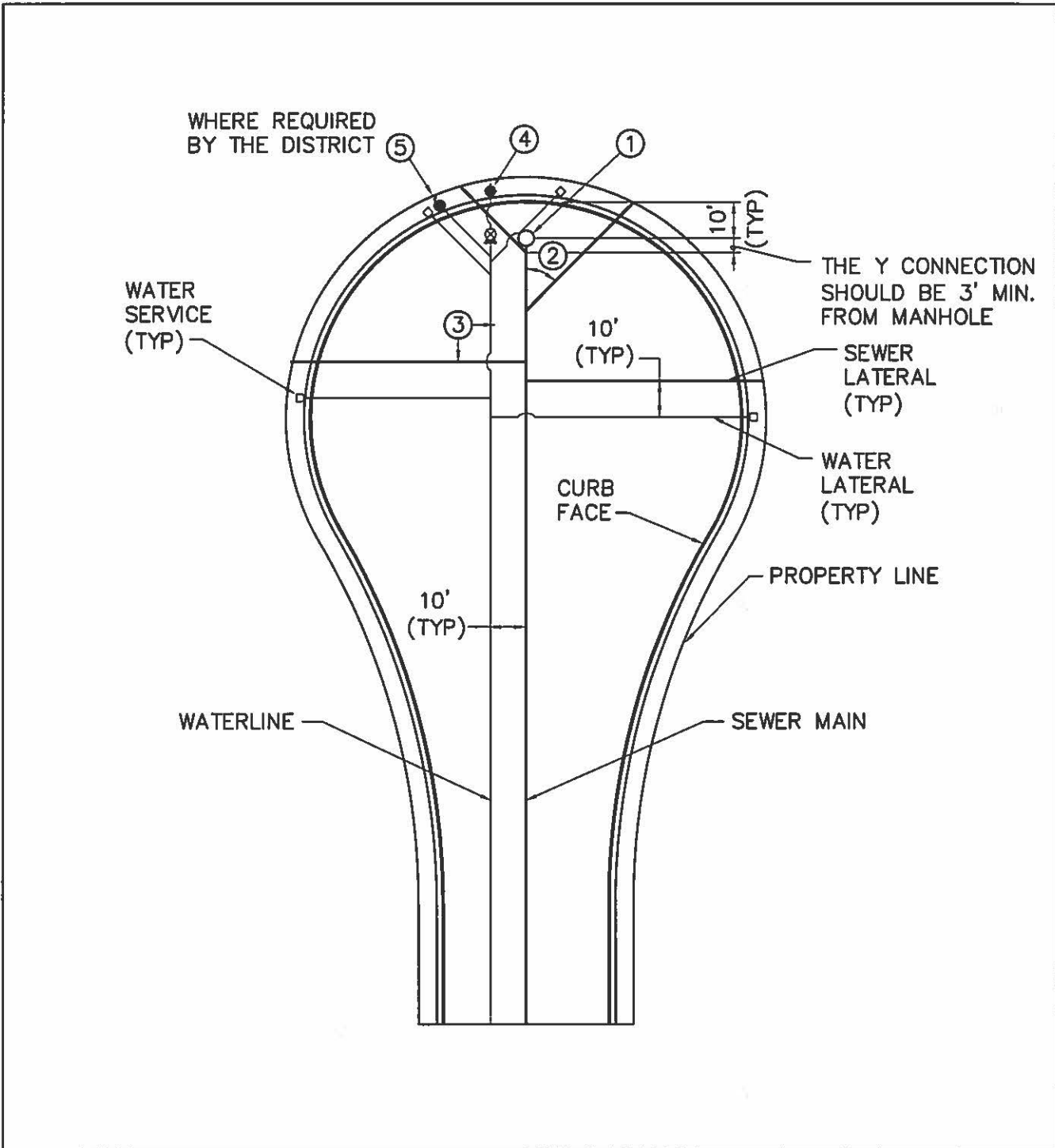

ITEM	DESCRIPTION
1	USE WATER-TIGHT MANHOLE COVER WHERE CUL-DE-SAC CREATES LOW POINT
2	45° ANGLE ONLY IF NECESSARY TO SERVE REAR LOTS (WATER & SEWER)
3	90° ANGLE (STANDARD) (WATER & SEWER)
4	END OF MAIN FIRE HYDRANT (TO SERVE AS A BLOWOFF). LOCATE TO CLEAR DRIVEWAYS
5	END OF MAIN A.V.A.R. (WHERE CUL-DE-SAC CREATES A HIGH POINT).



RAINBOW MUNICIPAL WATER DISTRICT

APPROVED: <i>Shayla K. ...</i>		
RCE # 79790 EXP.09/30/2016		
REVISION	APPROVED	DATE

STANDARD CUL-DE-SAC
SEWER LATERALS

STANDARD DRAWING NO.
S-11
JANUARY 2016

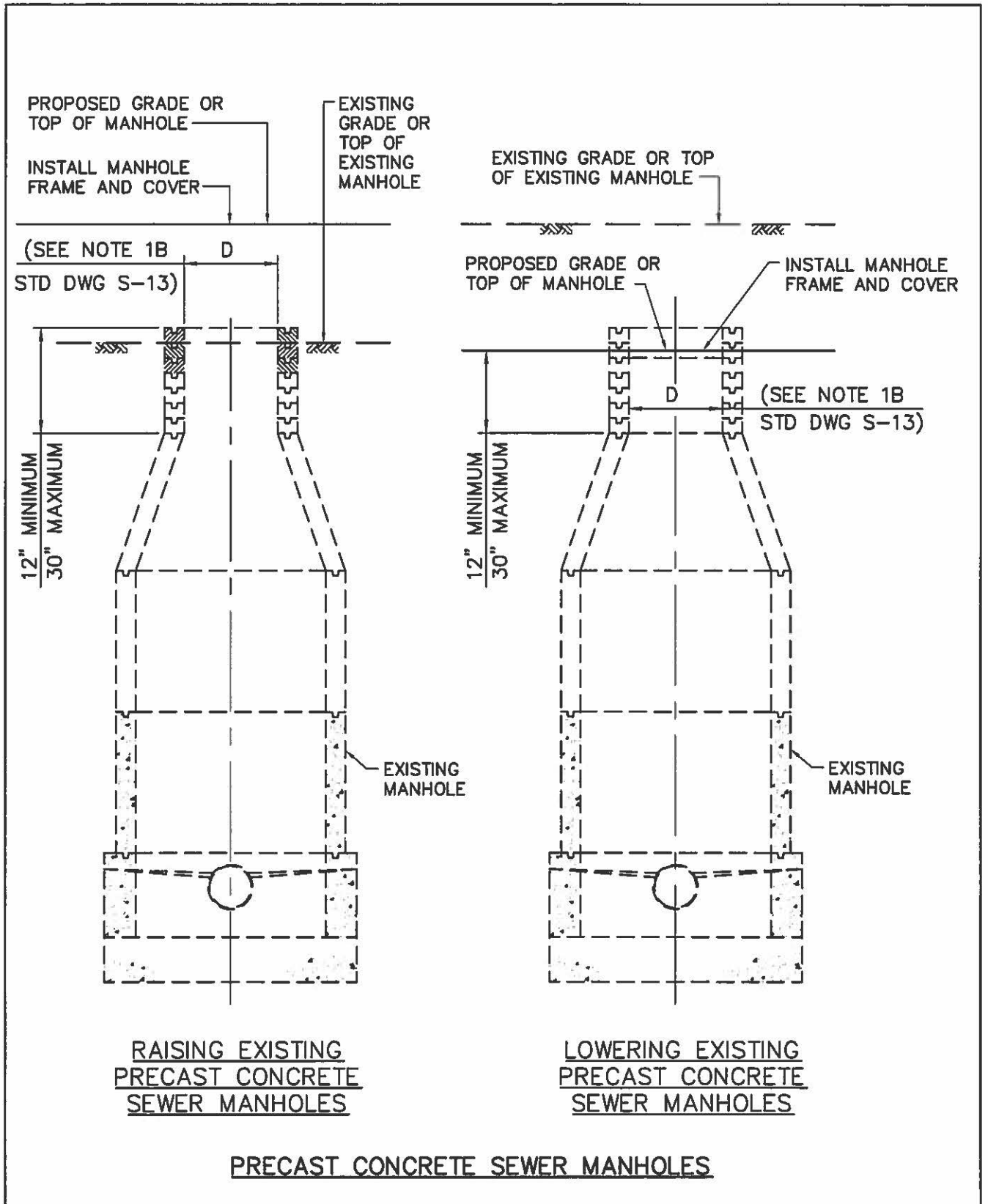

RAISING EXISTING
PRECAST CONCRETE
SEWER MANHOLES

LOWERING EXISTING
PRECAST CONCRETE
SEWER MANHOLES

PRECAST CONCRETE SEWER MANHOLES



RAINBOW MUNICIPAL WATER DISTRICT

APPROVED: *[Signature]*

RCE # 79790 EXP.09/30/2016

REVISION	APPROVED	DATE

SEWER MANHOLE ADJUSTMENT

STANDARD DRAWING NO.
S-12
JANUARY 2016

NOTES:

1. GENERAL
 - A. DIMENSION "D" SHALL BE THE SAME AS THE SIZE OF MANHOLE FRAME AND COVER TO BE USED.
 - B. THE CONTRACTOR MAY REUSE THE EXISTING MANHOLE FRAME AND COVER, UNLESS DAMAGED BY HIM DURING HIS CONSTRUCTION OPERATIONS OR WHEN OTHERWISE INDICATED ON THE PROJECT PLANS. ITEMS DAMAGED BY THE CONTRACTOR SHALL BE REPLACED WITH IDENTICAL NEW ITEMS AT NO EXPENSE TO THE AGENCY.

2. RAISING EXISTING PRECAST CONCRETE SEWER MANHOLES
 - A. PRECAST CONCRETE MANHOLES TO BE RAISED LESS THAN 3 INCHES MAY BE RAISED BY APPLYING CLASS "D" MORTAR TO THE TOP OF THE EXISTING MANHOLE, PROVIDED THE TOTAL HEIGHT OF MORTAR, EXISTING AND NEWLY APPLIED DOES NOT EXCEED 3 INCHES.
 - B. WHERE THE PRECAST CONCRETE MANHOLE IS TO BE RAISED 3 INCHES OR MORE, OR WHERE THE TOTAL HEIGHT OF MORTAR, EXISTING AND NEWLY APPLIED, WOULD EXCEED 3 INCHES, GRADE RINGS SHALL BE UTILIZED. CLASS "D" MORTAR MAY BE USED FOR FINAL ADJUSTMENT, BUT NOT MORE THAN 3 INCHES IN HEIGHT. WHERE RAISING THE MANHOLE WOULD RESULT IN THE UPPER SEGMENT OF THE SHAFT BEING MORE THAN 30 INCHES IN HEIGHT, REMOVE THE REDUCER AND THE UPPER SEGMENT OF THE SHAFT. INSTALL ADDITIONAL RINGS OR PIPE TO THE LOWER SEGMENT OF THE SHAFT AND REINSTALL THE REDUCER AND GRADE RINGS AS REQUIRED.

3. LOWERING EXISTING PRECAST CONCRETE SEWER MANHOLES
 - A. REMOVE SUFFICIENT GRADE RINGS TO LOWER THE MANHOLES AS REQUIRED. APPLY CLASS "D" MORTAR TO A HEIGHT NOT EXCEEDING 3 INCHES FOR ADJUSTMENT TO FINAL GRADE.
 - B. WHERE REMOVAL OF GRADE RINGS WOULD RESULT IN THE UPPER SEGMENT OF THE SHAFT BEING LESS THAN 12 INCHES IN HEIGHT, REMOVE THE REDUCER AND SUFFICIENT SECTIONS OF THE LOWER SEGMENT OF THE SHAFT AND REINSTALL ANY NECESSARY SEGMENT OF THE LOWER SHAFT, THE REDUCER, AND THE GRADE RINGS TO CONFORM TO THE REQUIREMENTS OF THIS PLAN.
 - C. EXISTING GRADE RINGS NEED NOT BE REMOVED IF EXISTING MORTAR IS REMOVED AND AT LEAST 1 1/2 INCHES OF MORTAR MAY BE PLACED ON TOP OF THE EXISTING GRADE RINGS TO RESEAT THE FRAME.



RAINBOW MUNICIPAL WATER DISTRICT

APPROVED: <i>John P. Krasinski</i>		
RCE # 79790 EXP.09/30/2016		
REVISION	APPROVED	DATE

**SEWER MANHOLE ADJUSTMENT
NOTES**

STANDARD DRAWING NO.
S-13
JANUARY 2016

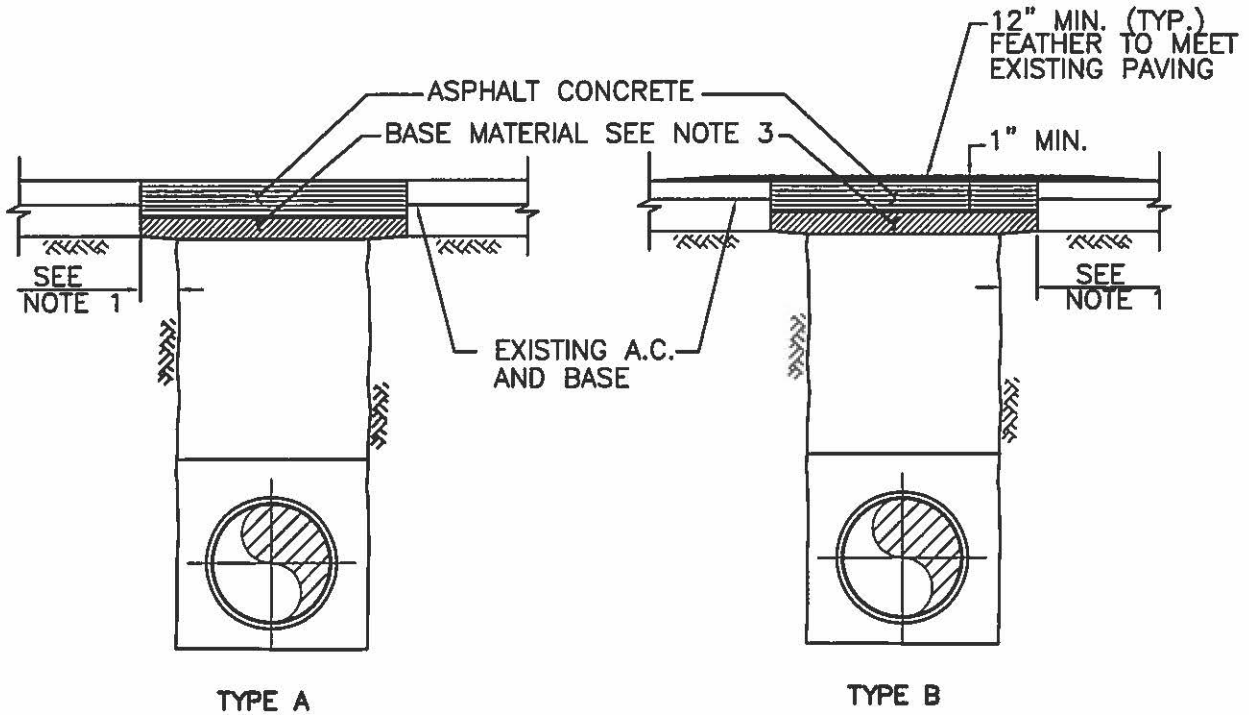

NOTES:

- 1) TRENCH EDGES TO BE CUT A MINIMUM OF 6" WIDER THAN TRENCH FOR TRENCHES 3' WIDE OR LESS, AND 12" WIDER FOR TRENCHES OVER 3' WIDE.
- 2) EXISTING AC SHALL BE CUT AND REMOVED IN SUCH A MANNER SO AS NOT TO TEAR, BULGE OR DISPLACE ADJACENT PAVEMENT. EDGES SHALL BE CLEAN AND VERTICAL. ALL CUTS SHALL BE PARALLEL OR PERPENDICULAR TO STREET CENTERLINE, WHEN PRACTICAL.
- 3) BASE MATERIAL TO BE REPLACED TO DEPTH OF EXISTING BASE OR 6" MINIMUM, AC MAY BE SUBSTITUTED FOR BASE MATERIAL.
- 4) A TACK COAT OF ASPHALT EMULSION OR PAVING ASPHALT SHALL BE APPLIED TO EXISTING AC OR P.C.C. CONTACT SURFACES, PRIOR TO RESURFACING.
- 5) ASPHALT CONCRETE RESURFACING:
 - A) MINIMUM TOTAL THICKNESS SHALL BE ONE INCH GREATER THAN EXISTING AC OR 3" MINIMUM,
 - B) AC SHALL BE HOT PLANT MIX CALTRANS SPEC GRADE C2-PG-64-10
 - C) FINISH COURSE FOR TYPE B RESURFACING SHALL BE LAID DOWN USING A SPREADER BOX.
- 6) ALL AC RESURFACING SHALL BE SEAL COATED WITH AN EMULSIFIED ASPHALT AND COVERED WITH SAND. CHIP SEALING TO BE APPLIED AS REQUIRED BY AGENCY.
- 7) TYPE B SHALL NOT BE USED ON LATERAL CROSSINGS.
- 8) SLOUGHING OF TRENCH UNDER PAVEMENT SHALL BE CAUSE FOR REQUIRING ADDITIONAL PAVEMENT AND BASE.



RAINBOW MUNICIPAL WATER DISTRICT

APPROVED: <i>[Signature]</i>		
RCE # 79790 EXP.09/30/2016		
REVISION	APPROVED	DATE

TRENCH RESURFACING
TYPES A & B

STANDARD DRAWING NO.
S-14
JANUARY 2016

APPROVED
MATERIALS LIST

**RAINBOW MUNICIPAL WATER DISTRICT
APPROVED MATERIALS LIST**

TYPE	DESCRIPTION OF MATERIAL	MANUFACTURER
ANODE, MAGNESIUM	HIGH OR STANDARD POTENTIAL ANODE WITH GALVANIZED STEEL CORE ENCASED IN SQUARE MAGNESIUM ALLOY. INGOT PRE-PACKAGED IN PERMEABLE COTTON CLOTH BAG FILLED WITH 75% GYPSUM, 20% BENTONITE, 5% SODIUM SULFATE MIX. PROVIDE INGOT WEIGHT AS SPECIFIED ON APPROVED PLANS. SEE STANDARD DRAWING CP-14.	HYTECH PIPELINES PRODUCTS CALPICO FARWEST CORROSION
ANODE, ZINC	PRE-PACKAGED 15 lbs MIN. SACRIFICIAL ANODE, #12 THHN LEAD WIRE, TO PROTECT COPPER TUBIN. SEE STANDARD DRAWINGS CP-16 and CP-17.	HYTECH PIPELINES PRODUCTS CP-Z15 TRIEPECONLINE CALPICO FARWEST CORROSION
BACKFLOW PREVENTION DEVICES	INSTALLED WITH METERS: REDUCE PRESSURE PRINCIPLE DEVICE FIRE SYSTEMS	WILKINS 975 XL2 APOLLO 4ALF WILKINS 950 XLT WILKINS 350 XLT APOLLO 4A-100 LF WILKINS-375
BOLTS AND NUTS, 304 SS	HEX-HEAD MACHINE, ASTM A193, GRADE B8 BOLTS AND ASTM A194, GRADE 8 NUTS	
BOLTS AND NUTS, 316 SS	HEX-HEAD MACHINE, ASTM A 193, GRADE B8M BOLTS AND ASTM A194, GRADE 8M NUTS. TRIPAC BLUE NUT.	TRIPAC FASTENERS PACIFIC COAST BOLT INDUSTRIAL THREADED PRODUCTS
BOLTS AND NUTS, A307 (CADMIUM/ZINC)	HEX-HEAD MACHINE, CADMIUM/ZINC PLATED, ASTM A307, GRADE A BOLTS AND A307 2H HEAVY HEX NUTS.	
BOLTS AND NUTS, A307 (FLUOROPOLYMER)	HEX-HEAD MACHINE, FLUOROPOLYMER COATED, ASTM A307, GRADE A BOLTS AND A307 2H HEAVY HEX NUTS	

TYPE	DESCRIPTION OF MATERIAL	MANUFACTURER
BOLTS AND NUTS, A307, BREAK AWAY, 19mm (3/4") FOR FIRE HYDRANTS	WET BARREL FIRE HYDRANT FLANGE BOLTS, HEX HEAD MACHINE, BREAK AWAY BOLTS, 3/4" x 3-1/4" AND NUTS. BOLTS SHALL INCORPORATE 13/32 for 3/4" HOLE DRILLED in BOLT SHAFT AND 2 3/8" DEEP FILLED WITH SILICONE SEALANT TO MEET ASTM C920. BOLTS AND NUTS SHAL BE ZINC PLATED ASTM A307 CARBON STEEL.	TRIPAC FASTENERS PACIFIC COAST BOLT INDUSTRIAL THREADED PRODUCTS
BURY ELLS	DUCTILE IRON, CEMENT LINED, RING-TITE BY FLANGE, 6 HOLE PATTERN, 6"X16" LONG RADIUS	SOUTH BAY FOUNDRY CLOW TYLER
CASING END SEAL	1/4" THICK STYRENE BUTADIENE RUBBER SHEET END SEAL. USE 1" WIDE STAINLESS STEEL BANDS. ZIPPERED END SEALS WITH STAINLESS STEEL BANDS MAY ALSO BE USED.	ADVANCED PRODUCTS SYSTEMS CASCADE CALPICO PIPELINE SEAL & INSULATOR POWERSEAL RAYCHEM
CASING SPACER	STAINLESS STEEL CASING SPACER, CENTER RESTRAINED, POSITION TYPE WITH PVC LINER AND NON-METALLIC ANTI-FRICTION RUNNERS	ADVANCED PRODUCTS SYSTEMS CASCADE PIPELINE SEAL & INSULATOR (PSI) POWERSEAL RAYCHEM CALPICO
CASTINGS	SEE STANDARD DRAWINGS FOR DIMENSIONS	
CASING CAP, VALVE MIN. WT. 24 LB.	8" MARKING "WATER" & "RMWD", 1208N 12" FOR BLOW OFF COVER,	SOUTH BAY FOUNDRY B6348 ALHAMBRA FOUNDRY
CATHODIC TEST STATION BOX	54 LB CONCRETE BODY WITH 12 LB DUCTILE IRON LID AND LID RING. "CP TEST" SHALL BE CAST INTO LID IN 1" LETTERS. FOR CATHODIC PROTECTION TEST STATIONS, ANODE GROUND BEDS AND INSULTAED FLANGE TEST STATIONS.	BROOKS 1-RT SERIES CHRISTY FARWEST TYPE 1-RT J & R Model V6-R
CLEAN OUT BOX		U.S. CONCRETE 5,000
COAL TAR	LOW GLASS, SELF-PRIMING COAL TAR MASTIC (COLOR = BLACK)	BITUMASTIC No. 50, (COLOR 0900)
CORPORATION STOPS (MALE)	1" AND 2" IRON PIPE THREAD BY MALE IRON PIPE THREAD, BALL CORP	JONES J1943 FORD F500 MCDONALD 73131B
CORPORATION STOPS (FEMALE)	1" AND 2" IRON PIPE THREAD BY FEMALE IRON PIPE THREAD, BALL CORP	FORD F1700 JONES J1931 MCDONALD 73149B

TYPE	DESCRIPTION OF MATERIAL	MANUFACTURER
CORPORATION STOP (MIP X MIP)	BRONZE MIP X MIP THREAD BALL VALVE (T-HEAD ONLY), 1" AND 2" FULL OPENING	JONES J-1943, J-1956 A.Y. MCDONALD 3131B MUELLER B-20013, B-2969
CORPORATION STOP (COMPRESSION)	ALL SIZES, 300 PSI	JONES J1935SG FORD FB1100 MCDONALD 74704BQ
COUPLING ADAPTOR, FLANGE	6" AND LARGER, MECHANICAL X FLANGE. STEEL OR DUCTILE IRON CONSTRUCTION WITHOUT ANCHOR PINS, EPOXY COATED, 304 STAINLESS STEEL BOLTS AND NUTS	DRESSER 127 FORD FFCA STYLE JCM 301 POWERSEAL 3521, 3528 ROMAC FCA501, FC400 SMITH-BLAIR 912, 913
COUPLING, FLEXIBLE	6" LONG PVC FLEXIBLE COUPLING WITH STAINLESS STEEL BANDS. USE FOR SECURING GATE VALVE CAP AND CAN ASSEMBLY TO 8" CLASS 200 PVC C900 GATE WELL	CALDER DFW/HPI FERNCO
COUPLING, STRAIGHT FLEXIBLE	4" AND LARGER, STEEL OR DUCTILE IRON CONSTRUCTION, SLIP X SLIP, EPOXY COATED WITH 304 OR 316 STAINLESS STEEL BOLTS AND NUTS. FOR USE ON AC, PVC, DI, OR STEEL PIPE.	APAC 301 FORD FC1 POWERSEAL 3501, 3538 ROMAC 501 SMITH-BLAIR 411 VIKING JOHNSON MAXIFIT
DEFLECTION BEND, PVC C900 AND C905	5° DEFLECTION BEND MANUFACTURED FROM C900 AND C905 PVC PIPE	IPEX
EPOXY ADHESIVE	HIGH-MODULUS, LOW VISCOSITY, EPOXY RESIN BASED ADHESIVE SUITABLE FOR GROUTING BOLTS OR DOWELS	SIKA SIKADUR 31, SIKADUR 35
FIRE HYDRANT	FOR 250 PSI AND BELOW 6" STANDARD WET BARREL DUCTILE IRON (DI) OR BRONZE FIRE HYDRANTS WITH SIX-HOLE BOLT PATTERN. DI FUSION EPOXY LINED. FOR 250 PSI AND GREATER USE THE AVK 24-72 OAE	CLOW 2050 OR 2060 AVK 24-42 OR 24-52 AVK 24-72 RATED AT 350 PSI
FITTINGS, COPPER	FITTINGS FOR SOFT SHALL BE JONES SUPERGRIP	JONES MCDONALD Q SERIES
FITTINGS, COMPRESSION	1" TO 2" METER VALVES (CURB) 300 PSI 1" TO 2" CORPORATION VALVES 300 PSI	JONES

TYPE	DESCRIPTION OF MATERIAL	MANUFACTURER
FITTINGS, DUCTILE IRON	FLANGED, MECHANICAL, JOINT OR PUSH-ON TEES, BENDS, CROSSES, REDUCERS, ADAPTERS, ETC., FOR WATER LINES 4" AND LARGER. MANUFACTURED PER AWWA C110, C111, C153. (SSB FITTINGS WILL NOT BE PERMITTED ON C905 PIPE.)	BACHMAN GRIFFIN NAPPCO/SIGMA PIPELINE COMPONENTS STAR TYLER
FITTINGS, PVC	4"-18" TEES. WYES, BENDS, CAPS, PLUGS, PER ASTM D-3034	GPK MULTI-FITTING PLASTIC TRENDS VYNYLTECH
FLANGES	WELD ON, COMPANION, REDUCING, BLIND-STANDARD AWWA CASTING	
GASKET	1/8" THICK FULL FACE OR RING, ARAMID FIBER BOUND WITH NITRILE. NO ASBESTOS CONTENT.	CALPICO GARLOCK 3000 JOHNS-MANVILLE KLINGER 4401 TRIPAC 5000
GROUT	NON-SHRINK CEMENT BASED CONSTRUCTION GROUT FOR CRACK REPAIR, FLOORING MORTAR, DOWEL GROUTING, CRACK SEALING AND GENERAL BINDING	REDLINE SPEEDCRETE FOR CML&C
INSULATION FLANGE KIT	FULL FACE OR TING	CALPICO
LUBRICANT, PIPE GASKET	RUBBER GASKET PIPE LUBRICANT FOR USE ON PVC OR DUCTILE IRON PIPE JOINTS, NSF LISTING REQUIRED	CHRISTY PRO-LUBE WHITLAM BLUE LUBE
MANHOLE, FRAME AND COVER	36" NOMINAL DIAMETER CAST IRON FRAME AND COVERS PER ASTM A48, CLASS 30, WITH MACHINED SEATS. INNER COVER: 155 POUNDS OUTER COVER: 320 POUNDS FRAME: 330 POUNDS MARKED WITH "SEWER" AND "RMWD" LOCKING COVER	ALHAMBRA FOUNDRY A-1325 SOUTH BAY FOUNDRY SBF-1325 MARCUN PRODUCTS
MANHOLE, JOINT SEALANT COMPOUND	PRE-FORMED, COLD APPLIED, ADHESIVE, ROPE-LIKE, BUTYL RUBBER GASKET TO FORM A WATER TIGHT SEAL BETWEEN MANHOLE SECTIONS	A-LOK, BUTYL LOK ASSOCIATED CONCRETE PRODUCTS, INC. QUIK-SEAL
MANHOLE, ODOR CONTROL	INSERT ACTIVATED CARBON GRANUALES	PARSON ENVIRONMENTAL PRODUCTS CARBON HDPE 24" RAINSTOPPER
MANHOLE, PIPE CONNECTOR	SAND COLLAR	GPK OR APPROVED EQUAL
MANHOLE, PIPE CONNECTOR	RUBBER FLEXIBLE TYPE CONNECTOR FOR PIPE TO MANHOLE CONNECTION FOR PRECAST MANHOLES	A-LOK, X-CELL NPC INC, KOR-N-SEAL

TYPE	DESCRIPTION OF MATERIAL	MANUFACTURER
METER BOX (20"X26")	20" x 26" HDPE METER BOX AND 2-PIECE COVER FOR 1" WATER SERVICES BLACK FOR POTABLE WATER USE; VIOLET FOR RECYCLED WATER USE.	CARSON INDUSTRIES MODEL 1220-12 WITH 1220-5 COVER
METER BOX (26"X39")	26" x 39" HDPE METER BOX WITH 2-PIECE COVER FOR 1.5" & 2" WATER SERVICES. BLACK COLOR. CONCRETE BOX IF 5' FROM TREES.	CARSON INDUSTRIES MODEL 1730-12 WITH 1730-5L COVER
METER FLANGES	1-1/2", 2" BRONZE OVAL W/ELONGATED HOLES	JONES J129 FORD 6F, 7F CARLON NO. 39004 MCDONALD 7610FDN
METER BUSHING, BRONZE SCRUBBER WASHER METERING STATION	1" X 1-1/4" FACTORY BUILT	MUELLER H10889 JONES J128-H MCDONALD 710J34 ENGINEERED FLUID, INC.
MORTAR, REPAIR	TWO COMPONENT, LOW SHRINKAGE, CEMENT BASED WITH HIGH COMPRESSIVE AND BONDING STRENGTH	SIKA SIKA TOP 122, 123 STO CR 735, CR 740
PAINT FOR CML&C WELD JOINTS	RUST INHIBITING PAINT FOR CML&C WELD JOINTS PRIOR TO EXTERIOR GROUTING	TNEMEC DEVOE CARBOLINE
PAINT FOR HYDRANTS, BLOWOFFS, AIRVACS, AND MARKER POSTS	PAINT SHALL BE SAFTEY YELLOW	RUSTOLIUM 7543
PIPE, COPPER	1" AND 2" TYPE K SOFT MUST BE ANNEALED	HALSTEAD MEULLER CERRO REDDING CAMBRIDGE-LEE
PIPE, DUCTILE IRON	4" – 24" 350 PSI WORKING PRESSURE 30" – 36" 250 PSI WORKING PRESSURE ZINC AND EPOXY FOR INTERIOR AND EXTERIOR COATING FOR SEWER	U.S. PIPE AMERICAN DUCTILE IRON PIPE ELECTROSTEEL PACIFIC STATES PIPE GRIFFIN PIPE
PIPE, POLYVINYL CHLORIDE	8" – 12" 150 PSI WORKING PRESSURE OR LOWER	VYNYLTECH
PIPE, STEEL SCHEDULE 40	4" THRU 12"	DOMESTIC, IMPORT

TYPE	DESCRIPTION OF MATERIAL	MANUFACTURER
PIPE, STEEL CEMENT MORTAR LINED AND COATED	10 OR 12 GAGE STEEL CYLINDER	KELLEY PIPE CEMENT LINING SPECIALTIES AMERON U.S. PIPE WEST COAST PIPE LINING, INC. LAKEWOOD PIPE SERVICE, INC. SAN DIEGO PIPE & SUPPLY NORTHWEST PIPE & CASING CO. KEENAN SUPPLY INC. MARCH PIPE CO. WATERWORKS SUPPLY
PIPE, SEWER, POLYVINYL CHLORIDE	4" THRU 15", ASTM D-1784, D-2321, D-2855, D-3034, SDR-35, F-477, 46 PSI MINIMUM STIFFNESS C900 SDR 18 FOR DEPTHS OVER 15' AND FORCE MAINS	J-M MFG. CO. VINYLTECH DIAMOND NORTH AMERICAN
PIPE, SEWER, POLYVINYL CHLORIDE	18" THRU 27" ASTM D-1784, D-2855 & F-679, SDR 35 MIN. 46 PSI STIFFNESS	VINYLTECH DIAMOND NORTH AMERICAN J-M MFG. CO.
PLASTIC ENCASMENT	8-MIL THICK POLYETHYLENE ENCASEMENT SLEEVE FOR DUCTILE IRON PIPE (DIP) PER AWWA C105.	
FACTORY BUILT CONTROL VALVE		ENGINEERED FLUID, INC.
SADDLES, SERVICE, FOR ACP, DI, AND PVC PIPE	BRONZE OR BRASS SADDLE WITH STAINLESS STEEL FOUR BOLT STRAP(S), IP THREAD OUTLET FOR SIZES 1" AND 2" FOR PIPE SIZES 4" THROUGH 12".	FORD 202BS JONES J-969 A.Y. MCDONALD 3846 MUELLER BR2S SERIES ROMAC 202BS SMITH-BLAIR 393
SADDLES, TAPPING	FABRICATED STEEL-SIDE OUTLET SIZE LESS THAN MAIN RUN	BAKER 428 INTERNATIONAL 228 ROCKWELL 622 JCM INDUSTRIES 412 ROMAC FTS-420
SADDLES, TAPPING	FABRICATED STEEL OR DUCTILE IRON - SIDE OUTLET SAME SIZE AS MAIN RUN	MUELLER 619 BAKER 430 ROCKWELL 623 JCM INDUSTRIES 414
SAMPLE STATION	CANISTER STEEL WATER TEST STATION (EPOXY-POWDER COATED) GOOSE NECK	PIPELINE PRODUCTS, WTS-858E (BLUE) KORALLEN ENTERPRISES

TYPE	DESCRIPTION OF MATERIAL	MANUFACTURER
SPOOLS, FIRE HYDRANT CAST IRON	INTEGRAL CASTING, 6-HOLE PATTERN, CEMENT LINED & SCORED	TYLER RICH LONG BEACH RELIABLE SOUTH BAY
TAPE	2" BLACK 10 MIL WAX TAPE AND PRIMER	CHRISTY'S CALPICO EXCOR TRENTON
TAPE, WARNING/ IDENTIFICATION	6" WIDE, WARNING/IDENTIFICATION (NON-METALLIC) MARKING TAPE FOR BURIED FACILITIES. TRACEABLE TAPE.	CALPICO, TYPE 1 LINE-TEC, TYPE B T. CHRISTY ENT., TYPE 1 TERRA TAPE, STANDARD 250 THOR, ELAST TEC NORTHTOWN
TRACER WIRE / BOXES / SPLICE KIT	AMERICAN WIRE GAUGE 14 AWG SNAKE PIT MAGNETIZED DIRECT BURY SPLICE KITS	COPPERHEAD INDUSTRIES 3M
VALVES, COMBINATION AIR & VACUUM	1", 2", 4" W/STAINLESS STEEL TRIM	APCO 143C, 145C, 149C CRISPIN ARI FLOW CONTROL ACCESSORIES D-040 ARV (Under Review)
VALVES, AIR RELEASE, ENCLOSURES	LDPE PLASTIC W/ UV INHIBITORS, BOLT DOWN BASE, REMOVABLE COVER W/ LOCK ENCLOSURE SIZE: 18" X 30" POTABLE WATER COLOR: YELLOW	PIPELINE PRODUCTS VCAS-1830 ARI FLOW CONTROL ACCESSORIES
VALVES, BALL (3/4" & 1")	3/4" AND 1" BRONZE, LEVER HANDLE W/SWIVEL METER NUT. 1-1/2" AND 2" BRONZE, SHORT LEVER HANDLE. HIP X	JONES J1908, J1913, J1966W FORD B11-332HB34LH, B11-444HB34LH B11-666HH67 B11-777HH67 MCDONALDS 76101MW – SHDLB
VALVES, BALL (1 1/2" & 2")	1-1/2" AND 2" BRONZE, FIP X FIP LEVER HANDLE 2" TEE HEAD	JONES J1905 JONES J1900 MCDONALDS 76101MW – SHDLB
VALVES, BALL (8" & LARGER)	8" AND LARGER 300# AWWA SPEC C07 MODEL 90RR DOUBLE RUBBER SEATED BALL VALVES, 250# FLANGES DUCTILE IRON BODIES S/S BALLS. WHEN USED BELOW GRADE MUST HAVE BURIED SERVICE WORM GEAR ACTUATORS S/S OPERATING NUT	MUELLER PRATT
VALVES, COMPRESSION	1" METER VALVES (CURB) 300 PSI 1 ½ TO 2" METER VALVE (CURB) 300 PSI	JONES J1963 WSG, J1925 WSG J1975 WSG, J1939 WSG

TYPE	DESCRIPTION OF MATERIAL	MANUFACTURER
VALVES, GATE – RESILIENT SEAT	4" THRU 12" - NON RISING STEM - MAY BE USED-AS TAPPING VALVE	AMERICAN FLOW CONTROL AVK HOLIDAY FREE
VALVES, PLUG	4" AND LARGER, LUBRICATED	
VALVES, PLUG - SEWER	4" THRU 12" DUCTILE IRON 285 NON-LUBRICATED	DEZURIK
VALVES, PRESSURE REDUCING		WILKINS 510XL

STANDARD FORMS

ENCROACHMENT PERMIT APPLICATION

ENCROACHMENT PERMIT

GRANT OF RIGHT OF WAY (EXCLUSIVE)

GRANT OF RIGHT OF WAY (NON-EXCLUSIVE)

NOTICE OF COMPLETION

QUICK CLAIM DEED

RMWD SIGNATURE BLOCK



ENCROACHMENT PERMIT APPLICATION

OWNERSHIP INFORMATION			
Owner Name:	Telephone No.:		
Address:			
REPRESENTATIVE INFORMATION			
Contractor:	License No.:	Telephone No.:	
Address:			
LOCATION OF PROPOSED ENCROACHMENT			
Address:			
APN:	Excavation Length:	Width:	Depth:
If pipe is to be placed, state Size and Type:			
Surface to be cut: <input type="checkbox"/> Asphalt <input type="checkbox"/> Concrete <input type="checkbox"/> Dirt			
Description (Attach Drawing):			

Rainbow Municipal Water District (District) Provisions:

The Contractor shall protect all existing improvements. Any existing improvements which are damaged or removed during the course of construction shall be repaired and/or replaced. All construction shall be in accordance with current District Standards and Specifications, approved plans, and the San Diego County Regional Standards. Construction shall not block or prevent access across the easement. The Owner must notify the District Inspector five (5) days prior to starting work and schedule two (2) working days during construction for inspections. The hours of work within the right-of-way shall be 7:00 a.m. to 3:30 p.m., Monday through Friday (excluding holidays). Upon completion of the work the applicant shall clean the right-of-way of all debris, trees, brush, excess materials, temporary structures and equipment. Grounds and landscaping shall be restored to the approval of the property owner. Approved encroachments will require an Encroachment Permit signed by the Owner and recorded at the County Recorder's Office. This application is subject to the approval of the District.

I hereby certify that all information provided in this application is true and I have read and agree to comply with the conditions listed above.

Owner Signature

Date

RECORDING REQUESTED BY:

Rainbow Municipal Water District

WHEN RECORDED RETURN TO:

Rainbow Municipal Water District
3707 Old Highway 395
Fallbrook, California 92028

ENCROACHMENT PERMIT NO. _____

Assessor's Parcel No. _____

An encroachment permit is hereby issued to the Owner designated in paragraph one, Attachment A, as the owner of the Benefitted Property described in paragraph two, Attachment A, to encroach upon Rainbow Municipal Water District ("District" herein) Easement or Property described in paragraph three, Attachment A, as detailed in the diagram, Attachment B. Attachments A and B are hereby incorporated herein by this reference as though fully set forth at length. In consideration of the issuance of this encroachment permit, Owner hereby covenants and agrees, for the benefit of the District, as follows:

1. This covenant shall run with the land and be binding upon and inure to the benefit of the future owners, encumbrances, successors, heirs, personal representatives, transferees, and assigns of District and Owner.
2. Owner shall use and occupy the District Easement or Property only in the manner and for the purposes described in paragraph four, Attachment A.
3. By accepting the benefits herein, Owner acknowledges that whatever rights and obligations are possessed by the District with respect to the District's Easement or Property shall remain and continue in full force and effect and shall in no way be affected by the District's issuance of this encroachment permit.
4. This encroachment permit may be revoked by the District in its sole discretion at any time, or abandoned by Owner with prior written notice to the District. Owner shall remove any and all encroachments prior to abandonment. The District shall mail written notice of revocation to Owner, addressed to the Benefitted Property, which shall set forth the date upon which the benefits of this encroachment permit are to cease.
5. The encroachment shall be installed and maintained in a safe and sanitary condition at the sole cost, risk, and responsibility of the Owner and successors in interest without exception, including, but not limited to, any damages to, or arising from, the encroachment caused by the District's maintenance or construction requirements.

6. The Owner shall at all times indemnify and save the District free and harmless from and pay in full, any and all claims, demands, losses, damages or expenses that the District may sustain or incur in any manner resulting from the construction, maintenance, state of use, repair or presence of the encroachment installed hereunder, including any loss, damage or expense arising out of (1) loss or damage to property, and (2) injury to or death of persons; excepting any loss, damage or expense and claims for loss, damage or expense resulting from the sole negligent act or acts of the District, its contractors, officers, agents or employees.
7. District is entitled to remove all or a portion of the Owner's encroachment in order to repair, replace, or install public improvements. District shall have no obligation to pay for or restore Owner's encroachments.
8. Whenever it is determined by the District that the District's Easement or Property cannot be economically used or maintained due to the presence of the encroachment, the District, in its sole discretion may revoke the encroachment permit at which time Owner shall remove all encroachments or require the Owner to provide an alternate right-of-way and/or to relocate the District's Easement or Property to a new alignment, all without cost or expense to the District.
9. Owner agrees to indemnify and hold the District harmless from and against all claims, demands, costs, losses, damages, injuries, litigation, and liability arising out of or related to the use, construction, encroachment or maintenance done by the Owner or Owners agents, employees or contractors on District Easement or Property.
10. Upon abandonment or revocation, Owner shall, at no cost to the District, return District Easement or Property to its pre-permit condition within the time specified in the notice of revocation or prior to the date of abandonment.
11. If Owner fails to restore the District Easement or Property, the District shall have the right, after notice to the Owner delivered at the Benefitted Property, to restore the District Easement or Property to its pre-permit condition (including the removal and destruction of any encroachments or improvements) and Owner agrees to reimburse the District for the costs incurred.
12. The Owner shall maintain a policy of liability insurance in an amount satisfactory to the District in order to protect the District from any potential claims which may arise from the encroachment.
13. If either party is required to incur costs to enforce the provisions of this covenant, the prevailing party shall be entitled to full reimbursement for all costs, including reasonable attorney's fees.
14. Owner agrees that Owner's duties and obligation under this covenant are a lien upon the Benefitted Property. Upon 30-day notice, and an opportunity to respond, the District may add to the tax bill of the Benefitted Property any past-due financial obligation owing to District arising hereunder.

- 15. Owner shall have no right to assert any claim or action against the District arising out of, or resulting from, improvements or any other action by the District, its officers, agents, or employees taken in a non-negligent manner, in accordance with the terms of this permit.
- 16. Owner recognizes and understands that this encroachment permit may create a possessory interest subject to property taxation and that the Owner may be subject to the payment or property taxes levied on such interest.
- 17. As a condition precedent to Owner's right to go upon the District Easement or Property, this permit must first be signed by the Owner, notarized, executed by the District and recorded with the County Recorder of the County of San Diego. The recording fee shall be paid by Owner.

Approved and issued by the Rainbow Municipal Water District in Fallbrook, California, this _____ day of _____, _____.

AGREED AND ACCEPTED:

By: _____
Signature of Owner

Date

Print Name

By: _____
Signature of Owner

Date

Print Name

--- NOTARIZATION REQUIRED ---

ISSUED:

RAINBOW MUNICIPAL WATER DISTRICT

By: _____
Engineering Manager

Date

--- NOTARIZATION REQUIRED ---

ATTACHMENT A

ENCROACHMENT PERMIT NO. _____

Assessor's Parcel No.

PARAGRAPH ONE:

Owner:

PARAGRAPH TWO:

Benefitted Property: (APN / Address)

PARAGRAPH THREE:

District Easement or Property:

PARAGRAPH FOUR:

Purpose: (Include project drawing as Attachment B)

RECORDING REQUESTED BY:

Rainbow Municipal Water District

WHEN RECORDED RETURN TO:

Rainbow Municipal Water District
3707 Old Highway 395
Fallbrook, California 92028

GRANT OF RIGHT OF WAY (Exclusive Only)

NO FEE REQUIRED PER
GOVERNMENT CODE SECTION 6103
DEED TRANSFER TAX: \$ 0
EXEMPT UNDER SEC. 11922 OF
REVENUE TAXATION CODE

Assessor's Parcel No. _____

For valuable consideration _____

as Grantor, hereby grants to Rainbow Municipal Water District, A Municipal Corporation, organized under the Municipal Water District Act of 1911 as amended, as Grantee, its successors and assigns, an easement and right of way _____ feet in width in, upon, over, under, and across the lands hereinafter described, to erect, install, construct, reconstruct, replace, repair, alter, operate, maintain, inspect and use a pipeline or pipelines for any and all purposes, together with any easement roads and appurtenances within the right-of-way including but not limited to conduits and cables for communication purposes, at such location and elevations, upon, along, over and under the hereinafter described right-of-way as Grantee may now or hereafter deem convenient and necessary from time to time, together with right of ingress thereto and egress therefrom to and along said right-of-way by a practical route or routes, in, upon, over, and across the hereinafter described lands, together with the right to clear and keep clear said right-of-way from buildings and structures.

The lands in which said easement of right-of-way is hereby granted are situated in the County of San Diego, State of California, and are particularly described as follows, to wit: **See Exhibit "A"**

Grantor hereby also grants to grantee the temporary use of such adjacent land of Grantor as is necessary to install the facilities provided for under the terms of the easement granted herein.

It is further understood and agreed that no other easement or easements shall be granted on, under, over said strip of land by the Grantor to any person, firm or corporation without the previous written consent of said grantee.

Grantor and _____ successors and assigns shall not erect or construct, or permit to be erected or constructed, any building, fences, walls, or other structures of any kind and no trees shall be installed, constructed, erected, placed, planted or maintained in any portion of the easement and right-of-way, and no shrubs or other, plants or vegetation shall be placed, planted or maintained in the portion of the easement and right-of-way which is included within any road, and that no changes in the alignment or grading of any such road will be made without prior written consent of Grantee. It is further understood and agreed the grantor shall not drill any well or wells within the limits of said right-of-way.

Grantee shall have the right to construct and utilize an access road within said easement and shall have

the right to erect, maintain and use gates in all of Grantor's fences which now cross or shall hereafter cross said route or routes, and to trim and cut and clear away any trees and brush whenever in its judgment the same shall be necessary for the convenient and safe exercise of the rights hereby granted, the right to transfer and assign this easement in whole or in part being hereby granted to the Grantee.

It is also understood and agreed by the parties hereto that the Grantor and successors or assigns, shall not increase or decrease, or permit to be increased or decreased the existing ground elevations of the above described right-of-way, existing at the time this document is executed, without the previous written consent of the Grantee.

IN WITNESS WHEREOF, the Grantor(s) executed this instrument this ____ day of _____, _____.

GRANTOR:

(Print Name)

(Sign Name)

(Print Name)

(Sign Name)

A notary public or other officer completing this certificate verifies only the identity of the individual who signed the document to which this certificate is attached, and not the truthfulness, accuracy, or validity of that document.

State of California)

County of)

)

On _____, before me, _____, Notary Public

personally appeared _____ who proved to me on the basis of satisfactory evidence to be the person(s) whose name(s) is/are subscribed to the within instrument and acknowledged to me that he/she/they executed the same in his/her/their authorized capacity(ies), and that by his/her/their signature(s) on the instrument the person(s) or the entity upon behalf of which the person(s) acted, executed this instrument.

I certify under PENALTY OF PERJURY under the laws of the State of California that the foregoing paragraph is true and correct.

WITNESS my hand and official seal.

Signature _____

Signature of Notary Public

CERTIFICATE OF ACCEPTANCE

This is to certify that the interest in real property conveyed by the Grant of Right of Way

dated _____ from _____,

to the Rainbow Municipal Water District, organized under the Municipal Water District Act of 1911, is hereby accepted by order of Board of Director's Resolution No.02-13, dated July 3, 2002, authorizing the General Manager to accept and record Grants of Right of Way on behalf of said District.

RAINBOW MUNICIPAL WATER DISTRICT

Dated _____

By _____
General Manager

Project Name: _____		
Water Alias Page No. _____	Checked by: _____	Date: _____

RECORDING REQUESTED BY:

Rainbow Municipal Water District

WHEN RECORDED RETURN TO:

Rainbow Municipal Water District
3707 Old Highway 395
Fallbrook, California 92028

GRANT OF RIGHT OF WAY (Non-Exclusive)

NO FEE REQUIRED PER
GOVERNMENT CODE SECTION 6103
DEED TRANSFER TAX: \$ 0
EXEMPT UNDER SEC. 11922 OF
REVENUE TAXATION CODE

Assessor's Parcel No. _____

For valuable consideration _____

as Grantor, hereby grants to Rainbow Municipal Water District, a municipal water district formed pursuant to the Municipal Water District Act of 1911 as amended, as Grantee, its successors and assigns, an easement and right of way _____ feet in width in, upon, over, under, and across the lands hereinafter described, to erect, install, construct, reconstruct, replace, repair, alter, operate, maintain, inspect and use a pipeline or pipelines for any and all purposes, together with any easement roads and appurtenances within the right-of-way including but not limited to conduits and cables for communication purposes, at such location and elevations, upon, along, over and under the hereinafter described right-of-way as Grantee may now or hereafter deem convenient and necessary from time to time, together with right of ingress thereto and egress therefrom to and along said right-of-way by a practical route or routes, in, upon, over, and across the hereinafter described lands, together with the right to clear and keep clear said right-of-way from buildings and structures.

The lands in which said easement of right-of-way is hereby granted are situated in the County of San Diego, State of California, and are particularly described as follows, to wit: **See Exhibit "A"**

Grantor hereby also grants to grantee the temporary use of such adjacent land of Grantor as is necessary to install the facilities provided for under the terms of the easement granted herein.

It is further understood and agreed that no other easement or easements shall be granted on, under, over said strip of land by the Grantor to any person, firm or corporation without the previous consent of said Grantee, with the exception of other utility easements and access easements granted to the homeowner's association or its members as required by the California Bureau of Real Estate and which terminate upon conveyance of fee title to the underlying property to the homeowner's association and/or its members, so long as no utility or access easement provided for herein may or will cause or require the relocation, repair or alteration of any Grantee facilities, including a pipeline or pipelines, or otherwise affect such Grantee facilities or Grantee's access to such facilities in any way. This easement shall remain exclusive as to the precise location and situs of Grantee's facilities.

Grantor and _____ successors and assigns shall not erect or construct, or permit to be erected or constructed, any building, fences, walls, or other structures of any kind and no trees shall be installed, constructed, erected, placed, planted or maintained in any portion of the easement and right-of-way, and no shrubs or other, plants or vegetation shall be placed, planted or maintained in the portion of the easement and right-of-way which is included within any road, and that no changes in the alignment or grading of any such road will be made without prior written consent of Grantee. It is further understood and agreed the grantor shall not drill any well or wells within the limits of said right-of-way.

Grantee shall have the right to construct and utilize an access road within said easement and shall have the right to erect, maintain and use gates in all of Grantor's fences which now cross or shall hereafter cross said route or routes, and to trim and cut and clear away any trees and brush whenever in its judgment the same shall be necessary for the convenient and safe exercise of the rights hereby granted, the right to transfer and assign this easement in whole or in part being hereby granted to the Grantee.

It is also understood and agreed by the parties hereto that the Grantor and successors or assigns, shall not increase or decrease, or permit to be increased or decreased the existing ground elevations of the above described right-of-way, existing at the time this document is executed, without the previous written consent of the Grantee.

IN WITNESS WHEREOF, the Grantor(s) executed this instrument this _____ day of _____, _____.

GRANTOR:

(Print Name)

(Sign Name)

(Print Name)

(Sign Name)

A notary public or other officer completing this certificate verifies only the identity of the individual who signed the document to which this certificate is attached, and not the truthfulness, accuracy, or validity of that document.

State of California)

County of)

)

On _____, before me, _____, Notary Public

personally appeared _____ who proved to me on the basis of satisfactory evidence to be the person(s) whose name(s) is/are subscribed to the within instrument and acknowledged to me that he/she/they executed the same in his/her/their authorized capacity(ies), and that by his/her/their signature(s) on the instrument the person(s) or the entity upon behalf of which the person(s) acted, executed this instrument.

I certify under PENALTY OF PERJURY under the laws of the State of California that the foregoing paragraph is true and correct.

WITNESS my hand and official seal.

Signature _____
Signature of Notary Public

CERTIFICATE OF ACCEPTANCE

This is to certify that the interest in real property conveyed by the Grant of Right of Way

dated _____ from _____

to the Rainbow Municipal Water District, formed pursuant to the Municipal Water District Act of 1911, is hereby accepted by order of Board of Director's Resolution No.02-13, dated July 3, 2002, authorizing the General Manager to accept and record Grants of Right of Way on behalf of said District.

RAINBOW MUNICIPAL WATER DISTRICT

Dated _____

By _____
General Manager

Project Name: _____
Water Atlas Page No. _____ Checked by: _____ Date: _____

RECORDING REQUESTED BY:

Rainbow Municipal Water District

WHEN RECORDED RETURN TO:

Rainbow Municipal Water District
3707 Old Highway 395
Fallbrook, California 92028

EASEMENT QUITCLAIM DEED

DEED TRANSFER TAX: \$ NONE NO CONSIDERATION
EXEMPT UNDER SEC 11922 REVENUE TAXATION CODE

Assessor's Parcel No. _____

For valuable consideration Rainbow Municipal Water District, A Municipal Corporation, organized under the Municipal Water District Act of 1911 as amended, as Grantor, hereby remise, release and forever quitclaim to _____ the following described real property:

A portion of that certain Easement and of Right of Way recorded ____ day of _____, _____ as Document No.: _____, of Official Records, in the County of San Diego, State of California, being more particularly shown and described in Exhibits "A" and "B" attached hereto and made a part hereof.

Rainbow Municipal Water District

Date: _____

By: _____
District General Manager

A notary public or other officer completing this certificate verifies only the identity of the individual who signed the document to which this certificate is attached, and not the truthfulness, accuracy, or validity of that document.

State of California)
County of San Diego)
)

On _____, before me, _____, Notary Public personally appeared _____ who proved to me on the basis of satisfactory evidence to be the person(s) whose name(s) is/are subscribed to the within instrument and acknowledged to me that he/she/they executed the same in his/her/their authorized capacity(ies), and that by his/her/their signature(s) on the instrument the person(s) or the entity upon behalf of which the person(s) acted, executed this instrument.

I certify under PENALTY OF PERJURY under the laws of the State of California that the foregoing paragraph is true and correct.

WITNESS my hand and official seal.

Signature _____
Signature of Notary Public

RECORDING REQUESTED BY:

Rainbow Municipal Water District

WHEN RECORDED RETURN TO:

Rainbow Municipal Water District
3707 Old Highway 395
Fallbrook, California 92028

NOTICE OF COMPLETION

NO FEE REQUIRED PER
GOVERNMENT CODE SECTION 6103

To: _____

Date: _____

Work Order No.: _____

Owner: Rainbow Municipal Water District
3707 Old Highway 395
Fallbrook, CA 92028

Date of Completion: _____

OWNER'S ESTATE OF INTEREST:

Easement _____ Fee Title _____ Encroachment Permit _____

Other (describe) _____

CONTRACTOR:

Name: _____

Address: _____

TITLE OF PROJECT: _____

DESCRIPTION OF PROJECT: _____

LEGAL DESCRIPTION OF SITE: _____

ADDRESS OF THE SITE: _____

Final payment will be made to the above contractor on or after thirty-five (35) calendar days from the recording date of this Notice of Completion, except where otherwise provided for by law.

VERIFICATION



I, the undersigned state that I am the _____ of the Rainbow Municipal Water District, the public agency authorizing the Work of Improvement referred to in the foregoing Notice of Completion; that I have executed such Notice of Completion on behalf of such public agency and likewise make this verification on behalf of said public agency; and that I have read said Notice of Completion and know the contents thereof and the facts therein stated are true of my own knowledge.

I declare under penalty of perjury under the laws of the State of California that the foregoing is true and correct.

Date and Place

Engineering Manager
Rainbow Municipal Water District

Distribution:
Original - County Recorder
Copy - Contractor, Finance, Project File

 <p>RAINBOW MUNICIPAL WATER DISTRICT <i>Committed to Excellence</i></p> <p>3707 S. Old Highway 395 Fallbrook, CA 92028 Water & Sewer Agency</p>	 <p>RAINBOW MUNICIPAL WATER DISTRICT <i>Committed to Excellence</i></p> <p style="text-align: center;">Approved Changes</p>		
	No.	Description	Approved By
<hr/> Date _____ Reviewed: Engineering Manager			



BOARD ACTION

BOARD OF DIRECTORS

July 26, 2016

SUBJECT

DISCUSSION AND POSSIBLE ACTION TO AWARD A PROFESSIONAL SERVICES AGREEMENT WITH NOBEL SYSTEMS, INC. FOR GEOVIEWER ONLINE, GEOVIEWER MOBILE, INFOR ENTERPRISE ASSET MANAGEMENT INTEGRATION, AND SPRINGBROOK CUSTOMER SERVICE SOFTWARE INTEGRATION

BACKGROUND

The District uses ESRI software called ArcMap to view, update, manage, and map District facilities. Prior to 2014, the District had an in-house GIS staff member to manage the data updates. In 2014 that person retired and the management of the GIS data was outsourced to Nobel Systems. The cost of managing the GIS through contract is a fraction of the cost of an in-house staff member and the resources provided by Nobel Systems are far greater than one individual, however dedicated and experienced, could provide the District. Nobel took over GIS update and data management in late 2014.

Traditional GIS software is expensive and is limited to the desktops that it is installed on. Further, its usefulness is limited to users who have the knowledge and experience using the software – a very small number at RMWD. Hard copy maps were generated from this data to distribute to District staff and updated periodically. With rapid growth coming to the District, paper based mapping systems are nearly always out of date for field personnel and are very challenging to update when changes in the maps are made.

During 2015, the District has been working with Nobel Systems to implement Nobel's GeoViewer Online and GeoViewer Mobile on a trial basis. GeoViewer Online is a web based GIS system that provides a streamlined user interface that is accessible to users of nearly any skill level. GeoViewer Mobile is an iPad application that allows for easy access to GIS data in the field as well as comprehensive data collection capabilities.

The District's objective is to provide GIS data to the casual user, in an easy-to-use, intuitive interface with the ability to access the information needed with little or no formal training. GeoViewer is hosted online and does not require any special software to run, making it available to all District employees. GeoViewer mobile is accessed through iPads, giving field staff access to current maps in the field.

It should be noted here that General Manager Tom Kennedy once worked for Nobel Systems, with his employment ending just under 10 years ago. Mr. Kennedy has no ongoing interests in Nobel Systems and while he is familiar with the staff and leadership at Nobel Systems, this was not the overriding reason for working with Nobel on this project. The District has worked with other GIS integrators over the years but the capabilities of the GeoViewer products was well above those from some competitors.

DESCRIPTION

The professional service agreement encompasses GIS data update services, hosting GeoViewer Online, GeoViewer Mobile, as well as integrations with the District's asset management software (Infor EAM) and financial software (Springbrook).

The Geoviewer applications have the following benefits:

- Provides access to interactive water and sewer maps from staff desktops through a web browser or iPad.
- Geographically links as-builts, easement data, and CCTV videos to assets in an easy to find manner.
- Provides field users with work assignments that are geographically aware
- Enables direct integration with geographic data repositories, asset management information, linked image libraries and other information associated with water system infrastructures.
- Functionality and look of Geoviewer can be revised to satisfy the needs of the District.
- Map updates can be submitted electronically to be reviewed and updated.
- Application tools to isolate pipelines for shutdowns, manage dig alert tickets and locate fleet vehicles.
- Shutdown processing of customers affected and notifications.

Integrations

Integrating disparate data sets is the key for this project. While GIS data on its own has great value in the office and the field, the power of the data is magnified greatly through tying together a wide variety of systems into a cohesive system. District staff have been working with Nobel Systems for the last several months on validating the technical requirements for integrations between the main data sources at the District and the results have been successful. This lengthy evaluation and testing program has resulted in this contract being brought forward for consideration.

Work will also include integrations with Infor EAM and Springbrook work order system to Geoviewer Mobile, allowing work orders generated in Infor EAM to be viewed and closed in the iPad. Further, a comprehensive suite of field data gathering forms are being created to manage a wide variety of common tasks and carefully document both the work done and asset condition. There is no limit to the number of these that can be created but at the outset of the project this will include the following:

- Wastewater Line Cleaning Inspections
- Wastewater Manhole Inspections
- Wastewater Lift Station Inspections
- Water Valve Turning
- Generator Inspections
- Construction Inspections for new developments

In each of these areas, users in the field will have custom data collection forms that will guide them through the inspections and provide detailed, District defined fields to gather information in a standardized format. Information gathered for each inspection will be recorded in the GIS and also replicated into Infor EAM to document each inspection against the asset inspected. Field staff will use the iPad camera to record images of their work and asset condition. The use of speech to text will allow even those who are not the greatest typists to add detailed notes to these reports. It is expected that we will generate several thousand of these reports per year and all will be easily searchable and allow for comprehensive analysis to spot trends in asset conditions.

Similarly, once the Springbrook Utility Billing and Customer Service software is fully implemented, field Customer Service representatives will have full access to customer data from the field on the iPad. This will allow for much better responsiveness to customer inquiries. All Service Orders that are generated within the Springbrook application will be duplicated within the EAM and linked to the water service. In this way, any work done on a water service that originates from the Operations department will be integrated with work that comes from the Customer Service department so that all parties will have full access to all information.

Construction inspection reports, which are now done by hand on sheets of paper, will move to the iPad where the inspector will have the ability to create much more detailed, and useful reports. The inspector

can easily document site conditions and photograph the assets as installed and these reports will be easily retrievable by all users, either in the office or in the field.

Technology

Nobel Systems has been a pioneer in the field of integrating disparate data sources into GIS for nearly two decades. During our piloting phase, we have already integrated the following to GeoViewer:

- GIS Data
- Sewer CCTV data
- As builts
- Live Vehicle Locations through vehicle tracking
- Infor EAM
- Accella Springbrook (still going through testing as it is not quite ready)
- Valve Exercising Machine (tracks torque and turns and feeds to GIS)
- Dig Alert Ticket Management
- Google Street View and Google maps

Nobel has developed a suite of cloud based tools that are used to monitor data in a wide variety of sources and ensure that data remains synced between these sources and the mobile devices. All data is updated every 10 seconds. If the data source can't update that fast, the data will be updated as quickly as the host system allows. This ensures that once a work order is created in the office it will be in the hands of the person in the field immediately for action. Figure 1 below shows the basic architecture of this syncing platform

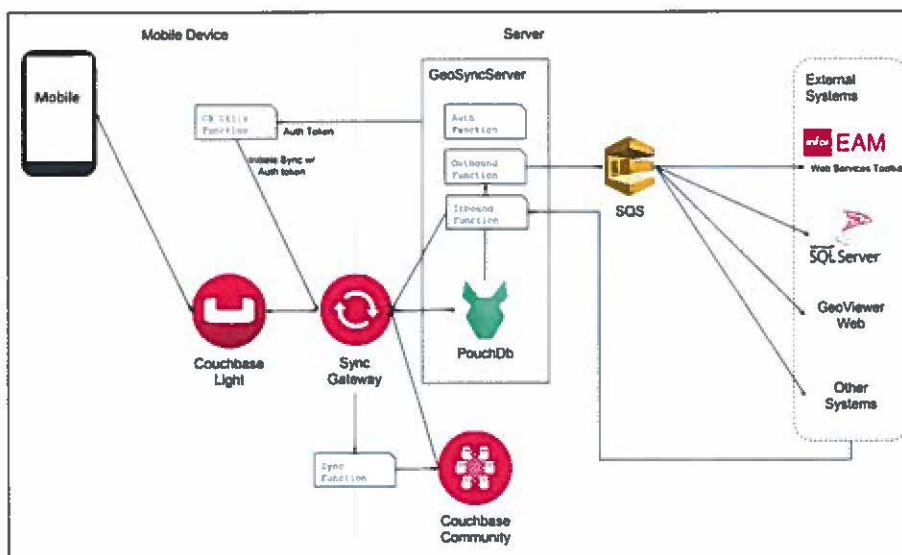

Figure 1: Nobel Systems Integration System

Long Term Benefits

As part of the Strategic Planning process undertaken in 2015, a key outcome was a desire to increase our ability to both manage assets and improve customer service. This contract is one of the outcomes of this process as it will meet a number of key long term objectives:

- Working with the EAM, the functionalities contained in this integration will generate a very comprehensive database on asset condition that will help guide decision making on asset replacements and other activities

- Working with the Customer Service software, this integration will allow the field Customer Service staff to significantly enhance their ability to interact with customers in a meaningful way. Staff will have full access to all customer information including billing and consumption and can resolve issues at the customer's site rather than having them wait for a response from the office. Once more advanced meter data from AMI is available, this will also allow for individualized discussions about water consumption trends right at the customer site.
- Through leveraging of vehicle position information and geographically located work orders, the system will allow for more efficient routing of work as well as geographical rather than departmental work assignments. This will leverage our in progress cross training program so that we reduce drive time significantly while increasing productivity. We project that drive time amounts to nearly 20% of all work time for field staff, so any decrease in driving will have an immediate, and substantial benefit to our productivity and costs.
- Having clearly defined work direction and standardized processes increases the capabilities of employees and reduces the length of time it takes to get new employees up to speed. This system will allow us to deploy more single person crews out into the field with a commensurate increase in productivity.
- While the cost of this service is substantial, it remains well under the cost for the single employee whose role was to simply maintain GIS data. This system provides a great deal more benefit and will increase productivity in a way that will more than pay for itself over time.

POLICY/STRATEGIC PLAN KEY FOCUS AREA

Asset Management – implement a proactive asset management system to include inventory of all assets and establish appropriate maintenance schedules.

Customer Service – enhance capabilities of field customer service staff through geographic dispatching and information systems.

BOARD OPTIONS/FISCAL IMPACTS

Contract amount is \$80,000 a year for 5 years. This was included in the 2016/2017 budget.

1. Approve the Professional Service Agreement with Nobel Systems, Inc.
2. Do not approve the Professional Service Agreement.

STAFF RECOMMENDATION

Staff recommends Option 1.



Michael Powers
Associate Engineer

July 26, 2016



**RAINBOW MUNICIPAL WATER DISTRICT
3707 S HIGHWAY 395
FALLBROOK CA 92028
(760) 728-1178**

PROFESSIONAL SERVICES AGREEMENT

**PROJECT: GEOVIEWER ONLINE / MOBILE APPLICATIONS HOSTING AND
INFORMATION INTEGRATIONS**

Project No. 100-100000 Water / 200-200000 Sewer, Contract No. 16-09

THIS AGREEMENT ("Agreement") is made and entered into this 23rd day of June, 2016 by and between the RAINBOW MUNICIPAL WATER DISTRICT, a municipal water district, hereinafter designated as "DISTRICT", and NOBEL SYSTEMS, INC. hereinafter designated as "CONSULTANT."

RECITALS

- A. DISTRICT desires to obtain Professional Consulting Services from an independent contractor for the above named project.
- B. CONSULTANT has submitted a proposal to provide professional services for DISTRICT in accordance with the terms set forth in this Agreement.
- C. DISTRICT desires to contract with CONSULTANT as an independent contractor and CONSULTANT desires to provide services to DISTRICT as an independent contractor.
- D. CONSULTANT has demonstrated its competence and professional qualifications necessary for the satisfactory performance of the services designated herein by virtue of its experience, training, education, and expertise.

NOW THEREFORE, THE PARTIES MUTUALLY AGREE AS FOLLOWS:

1. PROFESSIONAL SERVICES PROVIDED BY CONSULTANT.

- 1.1 The professional services to be performed by CONSULTANT shall consist of but not be limited to the following: Provide professional services in support of the District's GIS Water and Sewer data projects. CONSULTANT shall provide Geoviewer mapping, information technology and application development. Any additional services will be requested in writing as set forth in Section 19. The scope of services is more particularly defined in Exhibit "A", attached and made a part hereof.

1.2 In performing the services set forth in Exhibit "A", CONSULTANT shall work closely with DISTRICT'S General Manager and Staff in performing services in accordance with this Agreement in order to receive clarification as to the result that DISTRICT expects to be accomplished by CONSULTANT. The General Manager, shall be DISTRICT'S authorized representative in the interpretation and enforcement of all services performed in connection with this Agreement.

1.3 CONSULTANT represents that its employees have the qualifications and skills necessary to perform the services under this Agreement in a competent, professional manner, without the advice or direction of DISTRICT. This means CONSULTANT is able to fulfill the requirements of this Agreement. Failure to perform all services required under this Agreement constitutes a material breach of the Agreement.

2. TERM AND TIMING REQUIREMENTS.

2.1 This Agreement will become effective on the date stated above, and will continue in effect until the earlier of the completion of services provided for in this Agreement or until terminated as provided under Section 14 of this Agreement.

2.2 Performance of services under this Agreement shall be in accordance with the schedule outlined below unless otherwise modified in writing as set forth in Section 19. Failure by CONSULTANT to strictly adhere to these timing requirements may result in termination of this Agreement by DISTRICT.

Task	Date
NTP	June 30, 2016
Agreement Expiration	June 30, 2021

2.3 CONSULTANT shall submit all requests for extensions of time for performance in writing to the General Manager no later than two business days after the commencement of the cause of any unforeseeable delay beyond CONSULTANT'S control and in all cases prior the date on which performance is due if possible. The General Manager shall review all such requests and may grant reasonable time extensions for unforeseeable delays which are beyond CONSULTANT'S control.

2.4 For all time periods not specifically set forth herein, CONSULTANT shall respond in the most expedient and appropriate manner under the circumstances, by telephone, fax, hand delivery, e-mail or mail.

3. STUDY CRITERIA AND STANDARDS.

3.1 All services shall be performed in accordance with applicable DISTRICT, county, state and federal Codes and criteria. In the performance of its professional services, CONSULTANT shall use the degree of care and skill ordinarily exercised by CONSULTANTS performing the same or similar work under similar conditions.

4. INDEPENDENT CONTRACTOR.

- 4.1** CONSULTANT'S relationship to DISTRICT shall be that of an independent contractor in performing all services hereunder. DISTRICT shall not exercise any control or direction over the methods by which CONSULTANT shall perform its services and functions. DISTRICT'S sole interest and responsibility is to ensure that the services covered in this Agreement are performed in a competent, satisfactory and legal manner. The parties agree that no services, act, commission or omission of CONSULTANT or its employee(s) pursuant to this Agreement shall be construed to make CONSULTANT or its employee(s) the agent, employee or servant of DISTRICT. CONSULTANT and its employee(s) are not entitled to receive from DISTRICT vacation pay, sick leave, retirement benefits, Social Security, workers' compensation, disability benefits, unemployment benefits or any other employee benefit of any kind.
- 4.2** CONSULTANT shall be solely responsible for paying all federal and state employment and income taxes, for carrying workers' compensation insurance and for otherwise complying with all other employment requirements with respect to CONSULTANT or its employee(s). CONSULTANT agrees to indemnify, defend and hold DISTRICT harmless from any and all liability, damages or losses (including attorney's fees, costs, penalties and fines) DISTRICT suffers as a result of CONSULTANT'S failure comply with the foregoing.
- 4.3** CONSULTANT shall be solely responsible for the performance of any of its employees, agents, or subcontractors under this Agreement. CONSULTANT shall report to DISTRICT any and all employees, agents, and subcontractors performing services in connection with this Agreement, and all shall be subject to the approval of DISTRICT.
- 4.4** CONSULTANT shall have no authority, express or implied, to act on behalf of as an agent, or to bind DISTRICT to any obligation whatsoever, unless specifically authorized in writing by the General Manager. If CONSULTANT'S services relate to an existing or future DISTRICT construction contract, CONSULTANT shall not communicate directly with, nor in any way direct the actions of, any bidder for that construction contract without the prior written authorization by the General Manager.

5. WORKERS' COMPENSATION INSURANCE.

- 5.1** By CONSULTANT'S signature hereunder, CONSULTANT certifies that CONSULTANT is aware of the provisions of Section 3700 of the California Labor Code that require every employer to be insured against liability for workers' compensation or to undertake self-insurance in accordance with the provisions of that code, and CONSULTANT will comply with such provisions before commencing the performance of the services of this Agreement.

6. INDEMNIFICATION, HOLD HARMLESS AND DEFENSE.

- 6.1 All officers, agents, employees and subcontractors, and their agents, who are employed by CONSULTANT to perform services under this Agreement, shall be deemed officers, agents and employees of CONSULTANT. To the extent and in any manner permitted by law, CONSULTANT shall defend, indemnify, and hold DISTRICT, its directors, officers, employees, authorized volunteers and agents, and each of them free and harmless from any liability from loss, damage, or injury to property or persons, including wrongful death, that arise out of, pertain to, or relate to the negligence, recklessness or willful misconduct of CONSULTANT, including CONSULTANT'S officers, employees and agents, in connection with the services required by this Agreement, including without limitation, the payment of reasonable attorneys' fees and costs. The foregoing indemnity, hold harmless and defense obligation of CONSULTANT shall apply except to the extent the loss, damage or injury is caused by the sole negligence or willful misconduct of an indemnified party.
- 6.2 To the extent and in any matter permitted by law, CONSULTANT shall defend, indemnify and hold DISTRICT, its directors, officers, employees, authorized volunteers and agents, and each of them free and harmless from and against any and all actions, proceedings, damages, costs, expenses, penalties or liabilities, in law or equity, of every kind or nature whatsoever, arising out of, related to or incident to a breach of any governmental law or regulations, compliance with which is the responsibility of CONSULTANT.
- 6.3 CONSULTANT shall defend, at CONSULTANT'S own cost, expense and risk, any and all such aforesaid suits, actions or other legal proceedings of every kind that may be brought or instituted against DISTRICT or DISTRICT'S directors, officers, employees, authorized volunteers and agents, and each of them. DISTRICT shall be consulted regarding and approve of the selection of defense counsel. Should separate counsel be necessary for DISTRICT, as determined by DISTRICT, CONSULTANT shall be responsible to pay for the reasonable attorneys fees and costs including expert fees, as such fees and costs are incurred, for DISTRICT'S legal counsel in addition to CONSULTANT'S own legal fees and costs. In all circumstances, DISTRICT retains the right to retain its own attorneys.
- 6.4 CONSULTANT shall pay and satisfy any judgment, award or decree that may be rendered against DISTRICT or its directors, officers, employees, authorized volunteers and agents, and each of them, in any and all such aforesaid suits, action or other legal proceeding. CONSULTANT shall not agree without DISTRICT'S prior written consent, to any settlement which would require DISTRICT to pay any money or perform some affirmative act, including in the case of intellectual property infringement any payment of money or performance of some affirmative act to continue using CONSULTANT Products.
- 6.5 CONSULTANT shall reimburse DISTRICT and its directors, officers, employees, authorized volunteers and agents, and each of them, for any and all reasonable legal expenses and costs including attorneys' fees incurred by each of them in connection therewith or in enforcing the indemnity herein provided.
- 6.6 CONSULTANT agrees to carry insurance for this purpose as set forth herein including contract liability. Provision of insurance coverage as required by this Agreement shall not affect CONSULTANT'S indemnification, hold harmless and defense obligations. CONSULTANT'S indemnification hold harmless and defense obligation shall not be limited in any way by any limitation on the amount or type of damages, compensation or benefits payable by or for CONSULTANT, subcontractor, supplier or other person under workers'

compensation acts, disability acts or other employee acts or the insurance required by this Agreement. CONSULTANT'S obligation to indemnification, hold harmless and defense obligation shall not be restricted to insurance proceeds, if any received by DISTRICT or its directors, officers, employees, authorized volunteers or agents.

6.7 CONSULTANT'S indemnification, hold harmless and defense obligation shall survive the termination or expiration of this Agreement.

7. **LAWS, REGULATIONS AND PERMITS.**

7.1 CONSULTANT shall give all notices required by law and comply with all laws, ordinances, rules and regulations pertaining to the conduct of the services required by this Agreement. CONSULTANT shall be liable for all violations of the law in connection with services furnished by CONSULTANT. If CONSULTANT performs any services knowing it to be contrary to such laws, ordinances, rules and regulations, CONSULTANT shall bear all costs arising therefrom.

7.2 CONSULTANT shall comply with all of the following requirements with respect to any services as a Building/Construction Inspector, Field Soils and Material Tester, or Land Surveyor, as those trades are defined by the California Department of Industrial Relations ("DIR").

a) CONSULTANT agrees to comply with and require its subcontractors to comply with the requirements of California Labor Code sections 1720 *et seq.* and 1770 *et seq.*, and California Code of Regulations, title 8, section 16000 *et seq.* (collectively, "Prevailing Wage Laws") and any additional applicable California Labor Code provisions related to such work including, without limitation, payroll recordkeeping requirements. CONSULTANT and its subcontractors shall pay not less than the prevailing rate of per diem wages as determined by the Director of the DIR for all services described in this Section 7.2 of the Agreement and as required by law. The general prevailing wage determinations can be found on the DIR website at: [www://dir.ca.gov/dslr](http://www.dir.ca.gov/dslr). Copies of the prevailing rate of per diem wages may be accessed at the DISTRICT'S administrative office, and shall be made available upon request. CONSULTANT shall make copies of the prevailing rates of per diem wages for each craft, classification or type of worker needed to execute the services described in this Section 7.2 of the Agreement available to interested parties upon request, and shall post and maintain copies at CONSULTANT'S principal place of business and at all site(s) where services are performed. Penalties for violation of Prevailing Wage Laws may be assessed in accordance with such laws. For example, CONSULTANT shall forfeit, as a penalty to the DISTRICT, Two Hundred Dollars (\$200) for each calendar day, or portion thereof, for each workman paid less than stipulated prevailing rates for services performed under this Agreement by CONSULTANT, or any subcontractor under CONSULTANT, in violation of Prevailing Wage Laws. CONSULTANT shall defend, indemnify and hold the DISTRICT and its officials, officers, directors, employees, agents and volunteers free and harmless from any claims, liabilities, costs, penalties or interest arising out of the failure or alleged failure of CONSULTANT or its subcontractors to comply with Prevailing Wage Laws.

b) CONSULTANT and each of its subcontractors shall keep accurate payroll records showing the name, address, social security number, work classification, straight

time and overtime hours worked each day and week, and the actual per diem wages paid to each journeyman, apprentice, worker or other employee employed by CONSULTANT or subcontractor in connection with the services performed pursuant to this Agreement. Each payroll shall be certified, available for inspection, and copies thereof furnished as prescribed in California Labor Code section 1776, including any required redactions. CONSULTANT shall keep the DISTRICT informed as to the location of the records and shall be responsible for the compliance with these requirements by all subcontractors. CONSULTANT shall inform the DISTRICT of the location of the payroll records, including the street address, city and county and shall, within five (5) working days, provide a notice of a change of location and address. Penalties for noncompliance include a forfeiture of One Hundred Dollars (\$100) per calendar day, or portion thereof, for each worker until strict compliance is effectuated, which may be deducted from any moneys due to CONSULTANT.

- c) Eight (8) hours of work shall constitute a legal day's work. CONSULTANT and any subcontractors shall forfeit, as a penalty to the DISTRICT, Twenty-Five Dollars (\$25) for each worker employed in the execution of services pursuant to this Agreement by CONSULTANT or any subcontractor under him for each calendar day during which such worker is required or permitted to work more than eight (8) hours in any one (1) calendar day and forty (40) hours in any calendar week in violation of the provisions of the California Labor Code, in particular, sections 1810 to 1815, thereof, inclusive, except services performed by employees of CONSULTANT and its subcontractors in excess of eight (8) hours per day at not less than one and one-half (1 ½) times the basic rate of pay, as provided in California Labor Code section 1815.
- d) CONSULTANT'S attention is directed to the provisions of California Labor Code sections 1777.5, 1777.6 and 1777.7 concerning employment of apprentices by CONSULTANT or any of its subcontractors. If applicable to the services performed under the Agreement, CONSULTANT shall comply with such apprenticeship requirements and submit apprentice information to the DISTRICT. Information relative to apprenticeship standards, wage schedules and other requirements may be obtained from the DIR or the Division of Apprenticeship Standards. Knowing violations of section 1777.5 will result in forfeiture not to exceed One Hundred Dollars (\$100) for each calendar day of non-compliance pursuant to section 1777.7.
- e) CONSULTANT shall require any subcontractors performing services described in this Section 7.2 of the Agreement to comply with all of the above.

8. SAFETY.

CONSULTANT shall execute and maintain CONSULTANT'S services so as to avoid injury or damage to any person or property. In carrying out CONSULTANT'S services, CONSULTANT shall at all times, exercise all necessary precautions for the safety of employees appropriate to the nature of the services and the conditions under which the services are to be performed, and be in compliance with all federal, state and local statutory and regulatory requirements including State of California, Division of Industrial Safety (Cal/OSHA) regulations, and the U.S. Department of Transportation Omnibus Transportation Employee Testing Act (as applicable). Safety precautions as applicable shall include instructions in accident prevention for all employees such as safe walkways, scaffolds, fall protection, ladders, bridges, gang

planks, confined space procedures, trenching & shoring, equipment and wearing apparel as are necessary or lawfully required to prevent accidents or injuries.

9. INSURANCE.

9.1 INSURANCE COVERAGE AND LIMITS.

CONSULTANT shall provide and maintain at all times during the performance of this Agreement, insurance against claims for injuries to persons or damages to property which may arise from or in connection with the performance of the services hereunder by CONSULTANT, its agents, representatives, employees or subcontractors. Claims made policies shall not satisfy these insurance requirements unless CONSULTANT notifies DISTRICT and obtains DISTRICT'S prior written consent to the use of such claims made policies.

Coverage – CONSULTANT shall maintain coverage at least as broad as the following:

- a) Coverage for Professional Liability appropriate to CONSULTANT'S profession covering CONSULTANT'S wrongful acts, negligent actions, errors or omissions. The retroactive date (if any) is to be no later than the effective date of this Agreement.
- b) Insurance Services Office Commercial General Liability Coverage (Occurrence Form CG 0001).
- c) Insurance Services Office Automobile Liability Coverage (Form CA 0001), covering Symbol 1 (any auto).
- d) Workers' Compensation Insurance as required by the State of California and Employers Liability insurance.

Limits - CONSULTANT shall maintain limits no less than the following:

- a) Professional Liability - One million dollars (\$1,000,000) per claim and ~~two~~ one million dollars (~~\$2,000,000~~) (\$1,000,000) annual aggregate. (District Revision on 10/23/14).
- b) General Liability - Two million dollars (\$2,000,000) per occurrence for bodily injury, personal injury and property damage. If Commercial General Liability Insurance or other form with a general aggregate limit or products-completed operations aggregate limit is used, either the general aggregate limit shall apply separately to the project/location (with the ISO CG 2503, or ISO CG 2504, or insurer's equivalent endorsement provided to DISTRICT) or the general aggregate limit and products-completed operations aggregate limit shall be twice the required occurrence limit.
- c) Automobile Liability - One million dollars (\$1,000,000) for bodily injury and property damage each accident limit.
- d) Workers' Compensation insurance with statutory limits as required by California law and Employer's Liability insurance with a limit of no less than \$1,000,000 per accident for bodily injury or disease.

9.2 REQUIRED PROVISIONS. The insurance policies are to contain, or be endorsed to contain the following provisions:

- a) DISTRICT, its directors, officers, employees, or authorized volunteers are to be covered as insureds on the CGL and auto policies with respect to liability arising out of automobiles owned, leased, hired, or borrowed by or on behalf of CONSULTANT; and with respect to liability arising out of services or operations performed by or on behalf of CONSULTANT including materials, parts, or equipment furnished in connection with such services or operations. General liability coverage can be provided in the form of an endorsement to CONSULTANT'S insurance (at least as broad as ISO Form CG 20 10, 11 85 or both CG 20 10 and CG 20 37 forms if later revisions used). The coverage shall contain no special limitations on the scope of protection afforded to DISTRICT, its directors, officers, employees, or authorized volunteers.
- b) For any claims related to this services provided hereunder, CONSULTANT'S insurance shall be primary insurance as respects DISTRICT, its directors, officers, employees, and authorized volunteers. Any insurance, self-insurance, or other coverage maintained by DISTRICT, its directors, officers, employees, or authorized volunteers shall not contribute with it.
- c) Each insurance policy specified above are to state or be endorsed to state that coverage shall not be canceled except after thirty (30) days prior written notice (10 days for non-payment of premium) by U.S. mail has been provided to DISTRICT.
- d) In the event any change is made in the insurance carrier, scope of coverage or retroactive date of professional liability coverage required under this Agreement (if applicable), CONSULTANT shall notify DISTRICT prior to any changes
- e) All of the insurance shall be provided on policy forms satisfactory to DISTRICT. All insurance correspondence, notations, certificates, or other documents from the insurance carrier or agent/broker shall each separately reference DISTRICT this Agreement.

9.3 WAIVER OF SUBROGATION. CONSULTANT hereby agrees to waive rights of subrogation which any insurer of CONSULTANT may acquire from CONSULTANT by virtue of the payment of any loss. CONSULTANT agrees to obtain any endorsement that may be necessary to affect this waiver of subrogation. The Workers' Compensation policy shall be endorsed with a waiver of subrogation in favor of DISTRICT for all services performed by CONSULTANT, its employees, agents and subcontractors.

9.4 DEDUCTIBLES AND SELF-INSURED RETENTIONS. Any deductible or self-insured retention must be declared to and approved by DISTRICT. At the option of DISTRICT, the insurer shall either reduce or eliminate such deductibles or self-insured retention.

9.5 ACCEPTABILITY OF INSURERS. Insurance is to be placed with insurers having a current A.M. Best rating of no less than A:VII or equivalent or as otherwise acceptable DISTRICT.

9.6 EVIDENCES OF INSURANCE. Prior to execution of this Agreement, CONSULTANT shall furnish DISTRICT with original certificates and amendatory endorsements, or copies of the applicable insurance language, effecting coverage required by this Agreement. All

certificates and endorsements are to be received and approved by DISTRICT before services commence. However, failure to obtain the required documents prior the services beginning shall not waive CONSULTANT'S obligation to provide them.

CONSULTANT shall, upon demand of DISTRICT at any time, deliver to DISTRICT complete, certified copies or all required insurance policies, including endorsements, required by this Agreement.

- 9.7 **SUBCONTRACTORS.** In the event that CONSULTANT employs subcontractors as part of the services covered by this Agreement, it shall be the CONSULTANT'S responsibility to require and verify that each subcontractor meets the minimum insurance requirements specified in this Agreement.

10. **NO CONFLICT OF INTEREST.**

If CONSULTANT is providing services related to a DISTRICT project, CONSULTANT shall not be financially interested in any other contract necessary for the undertaking of the project. For the limited purposes of interpreting this section, CONSULTANT shall be deemed a "district officer or employee", and this section shall be interpreted in accordance with California Government Code Section 1090. In the event that CONSULTANT becomes financially interested in any other contract necessary for the undertaking of the project, this Agreement shall be null and void and DISTRICT shall be relieved of any responsibility whatsoever to provide compensation under the terms and conditions of any such contract for those services performed by CONSULTANT.

11. **OWNERSHIP OF DOCUMENTS.**

All documents and specifications, including details, computations, and other documents, prepared or provided by CONSULTANT under this Agreement shall be the property of DISTRICT. DISTRICT agrees to hold CONSULTANT free and harmless from any claim arising from any use, other than the purpose intended, of the documents and all preliminary sketches, schematics, preliminary plans, architectural perspective renderings, working drawings, including details, computations, and other documents, prepared or provided by CONSULTANT. CONSULTANT may retain a copy of all material produced under this Agreement for the purpose of documenting their participation in this project.

12. **CONFIDENTIAL INFORMATION.**

Any written, printed, graphic, or electronically or magnetically recorded information furnished by DISTRICT for CONSULTANT'S use are the sole property of DISTRICT. CONSULTANT and its employee(s) shall keep this information in the strictest confidence, and will not disclose it by any means to any person except with DISTRICT'S prior written approval, and only to the extent necessary to perform the services under this Agreement. This prohibition also applies to CONSULTANT'S employees, agents and subcontractors. On termination or expiration of this Agreement, CONSULTANT shall promptly return any such confidential information in its possession to DISTRICT.

13. **COMPENSATION.**

- 13.1 For services performed by CONSULTANT in accordance with this Agreement, DISTRICT shall pay CONSULTANT in accordance with the schedule of billing rates set forth in Exhibit

"A", attached hereto and incorporated herein by reference. No rate changes shall be made during the term of this Agreement. CONSULTANT'S compensation for all services performed in accordance with this Agreement shall not exceed the contract price of **\$80,000 per year for five years**. No services shall be performed by CONSULTANT in excess of the total contract price without prior written approval of the General Manager. CONSULTANT shall obtain approval from the General Manager prior to performing any services that result in incidental expenses to DISTRICT. CONSULTANT shall not change hourly rates without prior approval from the DISTRICT.

- 13.2** CONSULTANT shall maintain accounting records including the following information:
- a) Names and titles of employees or agents, types of services performed, and times and dates of all services performed in connection with Agreement that is billed on an hourly basis.
 - b) All incidental expenses including reproductions, computer printing, postage, mileage billed at current IRS Rate, and subsistence.
- 13.3** CONSULTANT'S accounting records shall be made available to DISTRICT Accounting Manager, for verification of billings, within a reasonable time of the Accounting Manager's request for inspection.
- 13.4** CONSULTANT shall submit monthly invoices to DISTRICT. DISTRICT shall make partial payments to CONSULTANT not to exceed the total contract price within thirty (30) days of receipt of invoice, subject to the approval of the General Manager. *Each application for partial payment shall be accompanied with a Progress Report summarizing the status of the services performed.*
- 13.5** CONSULTANT shall ensure that any report generated under this Agreement shall comply with Government Code Section 7550.

14. TERMINATION OF AGREEMENT.

- 14.1** If DISTRICT ("demanding party") has a good faith belief that CONSULTANT is not complying with the terms of this Agreement, DISTRICT shall give written notice of the default (with reasonable specificity) to CONSULTANT and demand the default to be cured within ten (10) days of the notice.
- 14.2** If CONSULTANT fails to cure the default within ten (10) days of the notice, or if more than ten (10) days are reasonably required to cure the default, and CONSULTANT fails to give adequate assurance and due performance within ten (10) days of the notice, DISTRICT may terminate this Agreement upon written notice to CONSULTANT.
- 14.3** In the event of a material breach of any representation or term of this Agreement by CONSULTANT that is not curable or results in a threat to health or safety, DISTRICT may immediately terminate this Agreement by providing prior written notice and without a cure period.
- 14.4** Upon termination, DISTRICT shall pay CONSULTANT for any services completed up to and including the date of termination of this Agreement, in accordance with the compensation Section 13. DISTRICT shall be required to compensate CONSULTANT only

for services performed in accordance with the Agreement up to and including the date of termination.

15. ASSIGNMENT AND DELEGATION.

15.1 This Agreement and any portion thereof shall not be assigned or transferred, nor shall any of CONSULTANT'S duties be delegated or subcontracted, without the express written consent of DISTRICT. Any attempt to assign or delegate this Agreement without the express written consent of DISTRICT shall be void and of no force or effect. Consent by DISTRICT to one assignment shall not be deemed to be consent to any subsequent assignment.

15.2 This Agreement shall inure to the benefit of and be binding upon the parties hereto and their respective successors and assigns.

16. AUDIT DISCLOSURE.

Pursuant to Government Code section 8546.7, if the Agreement is over ten thousand dollars (\$10,000), it is subject to examination and audit of the State Auditor, at the request of DISTRICT or as part of any audit of DISTRICT, for a period of three (3) years after final payment under the Agreement. CONSULTANT shall cooperate with any such examination or audit at no cost to DISTRICT.

17. ENTIRE AGREEMENT.

This Agreement, and the attached Exhibit "A", comprise the entire integrated understanding between DISTRICT and CONSULTANT concerning the services to be performed pursuant to this Agreement and supersedes all prior negotiations, representations, or agreements whether express or implied, oral or written. The express terms hereof control and supersede any course of performance and/or usage of the trade inconsistent with any of the terms herein. In the event of any conflict between the provisions of the Agreement and the Exhibit(s), the terms of the Agreement shall prevail.

18. INTERPRETATION OF THE AGREEMENT.

18.1 The interpretation, validity, and enforcement (including, without limitation, provisions concerning limitations of actions) of the Agreement shall be governed by and construed under the laws of the State of California, notwithstanding any conflict-of-laws doctrines of such state or other jurisdiction to the contrary and without the aid of any canon, custom or rule requiring construction against the draftsman. The Agreement does not limit any other rights or remedies available to DISTRICT.

18.2 CONSULTANT shall be responsible for complying with all applicable local, state, and federal laws whether or not said laws are expressly stated or referred to herein.

18.3 Should any provision herein be found or deemed to be invalid, the Agreement shall be construed as not containing such provision, and all other provisions which are otherwise lawful shall remain in full force and effect, and to this end the provisions of this Agreement are severable.

18.4 Each and every provision of law and clause required by law to be inserted in this Agreement shall be deemed to be inserted herein, and the Agreement shall be read and enforced as though they were included herein. If through mistake of otherwise any such provision is not inserted, or is not correctly inserted, then upon application of either party, the Agreement shall forthwith by physically amended to make such insertion.

19. AGREEMENT MODIFICATION.

This Agreement may not be modified orally or in any manner other than by an agreement in writing signed by the parties hereto.

20. DISPUTE RESOLUTION.

Any controversy or claim arising out of or relating to this AGREEMENT, or concerning the breach or interpretation thereof, shall be settled by submission of the matter to mediation the cost of which shall be borne equally by the parties. Nothing herein waives or excuses compliance with the California Government Claims Act.

21. JURISDICTION, FORUM AND VENUE.

The proper jurisdiction, forum and venue for any claims, causes of action or other proceedings concerning this Agreement shall be in the state and federal courts located in the State of California, County of San Diego. DISTRICT and CONSULTANT agree not to bring any action or proceeding arising out of or relating to this Agreement in any other jurisdiction, forum or venue. DISTRICT and CONSULTANT hereby submit to personal jurisdiction in the State of California for the enforcement of this Agreement and hereby waive any and all personal rights under the law of any state to object to jurisdiction within the State of California for the purposes of any legal action or proceeding to enforce this Agreement whether on grounds of inconvenient forum or otherwise.

22. MAILING ADDRESSES.

Notices given pursuant to this Agreement shall be deemed communicated as of the earlier of the day of receipt or the fifth day after deposit in the United States mail, postage prepaid, and addressed to the following:

CONSULTANT: Nobel Systems, Inc.
436 E. Vanderbilt Way
San Bernardino, CA 92408
Phone: (909) 890-5611

DISTRICT: Rainbow Municipal Water District
3707 Old Hwy 395
Fallbrook, CA 92028
Phone: (760) 728-1178

Notices delivered personally will be deemed communicated as of actual receipt.

23. SIGNATURES.

The parties each represent and warrant that the individuals executing this Agreement on their behalf have the right, power, legal capacity and authority to enter into and to execute this Agreement in such capacity.

24. COUNTERPARTS.

This Agreement may be executed in counterparts, each of which shall constitute an original, but all of which together shall constitute one and the same agreement, and the signature of any party to any counterpart shall be deemed to be a signature to, and may be appended to, any other counterpart.

25. ATTORNEY'S FEES.

In the event of a dispute arising under terms of this contract, it is agreed that the prevailing party may be awarded reasonable attorneys' fees and actual costs.

IN WITNESS WHEREOF the parties hereto for themselves, their heirs, executors, administrators, successors, and assigns do hereby agree to the full performance of the covenants herein contained and have caused this Agreement to be executed.

NOBEL SYSTEMS, INC. _____

RAINBOW MUNICIPAL WATER DISTRICT _____

By Michael - MICHAEL SAMUEL
CONSULTANT

By _____
GENERAL MANAGER

Date: 6/23/2016

Date: _____

77-0323606
Federal Employee ID #

Attest: Executive Secretary

Approved as to Form:
General Counsel

NOTARY ACKNOWLEDGEMENT OF CONSULTANT MUST ACCOMPANY THIS DOCUMENT

SEE ATTACHED

ACKNOWLEDGMENT

A notary public or other officer completing this certificate verifies only the identity of the individual who signed the document to which this certificate is attached, and not the truthfulness, accuracy, or validity of that document.

State of California
County of SAN BERNARDINO

On JUN 23 2016 before me, ROBERT A DE LA ROSA (NOTARY PUBLIC)
(insert name and title of the officer)

personally appeared MICHAEL SAMUEL
who proved to me on the basis of satisfactory evidence to be the person(s) whose name(s) is/are subscribed to the within instrument and acknowledged to me that he/~~she~~/they executed the same in his/~~her~~/their authorized capacity(ies), and that by his/~~her~~/their signature(s) on the instrument the person(s), or the entity upon behalf of which the person(s) acted, executed the instrument.

I certify under PENALTY OF PERJURY under the laws of the State of California that the foregoing paragraph is true and correct.

WITNESS my hand and official seal.

Signature  (Seal)

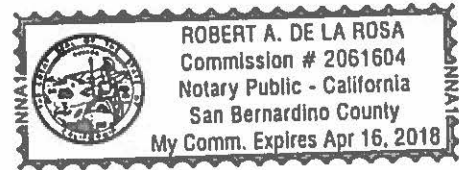

EXHIBIT "A"**SCOPE OF SERVICES****GEOVIEWER ONLINE / MOBILE APPLICATIONS HOSTING AND INFORMATION INTEGRATIONS**

The District's objective is to provide Geographical Information System data to the casual user. The Consultant shall provide an easy-to-use, intuitive interface to Geographic Information Systems for the casual user with the ability to access the information needed with little or no formal training. The Consultant shall provide the following Geoviewer online and mobile applications hosting with infor integrations in support of the District's water and sewer data projects as follows:

TASK 100 - GEOVIEWER ONLINE

The ESRI Platform is built on ArcGIS API for Flex with ArcGIS Server as the backend, which is configured to read the ArcSDE/SQL database. GeoViewer shall ultimately allow access to data for other aspects of the utility systems, such as Customer Service, Field Operations, Engineering, Finance, and any other enterprise data in which to connect. The main objectives of the system include:

- Ability for non-GIS staff to use the system effectively with less than four hours of training.
- Provide access to interactive water atlas maps from staff desktops through web browser.
- Locate and view an area of interest anywhere within the water system service area.
- Provide secured access to only authorized users.
- Map updates are seamlessly delivered to system users without any lag time.
- Provide an extensible system that can be enhanced to provide broader functionality and adapt to future software and functionality enhancements.
- Enable direct integration with geographic data repositories, asset management information, linked image libraries, and other information associated with water system infrastructures.

The GeoViewer was designed with the following assumptions in mind:

- Casual GIS users want fast, easy access to relevant information.
- Casual GIS users don't have the time or desire to learn about topology, Shapefiles, ARC/INFO, theories of GIS, etc.
- Casual GIS users don't want to have to add themes, assign colors, change theme properties, etc.
- Casual GIS users don't want to be bothered with the task of doing map composition. They would much rather has the ability to print their maps with a standardized template.
- Casual GIS users don't typically need to make large maps themselves and are perfectly happy printing an 8 1/2 by 11 map on a laser or ink jet printer. For the more advanced users, GeoViewer Online Supports multiple paper sizes that it's only restriction is the clients printing device.
- The GeoViewer is a robust and easy to use Enterprise Geographic Information Interface. The GeoViewer is extremely flexible and can be tailored to any dataset.

The functionality provided by GeoViewer shall satisfy the needs of the District. The list of features provided by GeoViewer includes but is not limited to:

- Standard map navigation including pan, zoom in and zoom out, full extent.
- Layer Legend Display.
- Creation of Spatial Bookmark.
- Google Street View.
- Vicinity map that can be used to set the extent of main map, pan the main map, and display the current extent of the main map.
- Property Search. Search by parcel number, situs address, or owner name.
- Supports ESRI Shapefiles, Coverages, Geodatabases, and CAD Drawings.
- Also supports a wide variety of images including MrSid.
- Intuitive Select Toolbar, Select multiple features in multiple themes, find features within a specified distance, and generate mailing labels.
- Measure area and length.
- Display contents of the selected set in a table format.
- Print map with a title, scale, and neat line.
- Link any number of layers to unlimited number of external databases.
- Hyperlink scanned documents to features for easy retrieval.
- Selecting Features and obtaining information about them.
- Select by user-defined radial buffer surrounding selected parcel(s), box and Polygon.
- Search Mechanism.
- Property Search: Search by parcel number, situs address, owner name, street intersection, X & Y coordinates, Latitude & Longitude.
- Print maps using predefined templates containing title, scale, neat line, north arrow and disclaimer.
- Print map with standard printing options such as different orientations (portrait or landscape), various paper sizes.
- Add/Include basemap types such as Google Street View, Aerials etc.
- Viewing Documents and Information behind maps.
- Valve Isolation and Print Mailing Labels: Print Mailing labels (compatible to office product offerings from 3M, Avery and other label manufacturers).

TASK 200 - GEOVIEWER MOBILE

GeoViewer for iPad is designed to provide practical functionality to non-GIS users. The solution enables users to take advantage of the power of GIS maps in daily work life in and out of the office.

Portable Architecture:

GeoViewer for iPad is easy to deploy on iPad devices. It runs in both connected and disconnected modes, enabling data collection anytime, even where there is no wireless signal available. GeoViewer for iPad's store & forward technology provides automatic upload of data without the user initiating complex import and export procedures.

Powerful Functionality:

- **Online/Offline Work Modules.**
- **Customized Modules for ERP Systems Integration.**
- **Search, Display, Redlining, Bookmarks, Pan, Zoom.**
- **Identify & View Object Locations & Asset Data.**
- **View Customer Data, Work History, Service Calls, As-Built De-sign Drawings, and more.**
- **Process Driven Modules for Daily Field Work Order, Inspections and Condition Assessment data collection.**
- **Integrated GPS & Camera for Field Data Collection & Stream-lined GIS Updates.**
- **Custom GeoViewer Modules available for USA Dig Alert, Work/Service Order Management, Valve Isolation Analysis, Leak Data Collection and Hydrant Flushing data collection.**
- **Rainbow Water team can view the data that were collected in the field thru iPad and generate the reports by using GeoViewer online application.**

Access and View Documents:

- **Add field notes with location metadata, attach photos and images with ability to add redlines.**
- **Share map snapshots with colleagues and supervisors for timely action.**
- **Bookmark areas of interest.**
- **Take photos and videos to include in notes linked to a lot, hydrant, valve, etc.**
- **Manage work orders from your work order or service order management systems, even without network connectivity.**
- **Provides a streamlined process to access and manage USA DigAlert tickets.**
- **Easy to use preventive maintenance workflows with access to historical data.**
- **Capture data from your valve turning machines right in the field to perform useful analysis and monitoring.**
- **Provide an easy to use workflow to report leaks from the field.**
- **Seamlessly integrates to the GeoViewer Online application enabling access to field data for supervisors and personal working from the office.**

Requirements:

GeoViewer is an application platform developed by Nobel Systems that includes web services and client applications. GeoViewer Online and GeoViewer for iPad are integral part of this application architecture. The functionality of these client applications complements each other to add value to the organization.

In order to get the full benefit of GeoViewer for iPad, Nobel Systems requires the licensing of GeoViewer Online. GeoViewer for iPad is not licensed as a standalone component an active maintenance license of GeoViewer Online is required for the proper functioning of GeoViewer for iPad.

TASK 300 - INFOR AND SPRINGBROOK INTEGRATION WITH GEOVIEWER MOBILE

The Consultant shall integrate the Infor work order system to GeoViewer Mobile, allowing Work Orders generated in Infor to be viewed and closed in the iPad.

Main Screen:

On the main screen of GeoViewer Mobile, the user will be able to see the Work Orders, which are assigned to them.

GeoViewer Mobile will automatically sort the Work Orders by priority. The priorities and assignments are setup by the Infor EAM.

By default the users will see the Work Orders assigned to them, but they can also switch to see all the Work orders.

If the user selects on the Work Order in the side bar, then GeoViewer will zoom to the area of the map where the Work order is located.

If the user sees a Work order on the map, in which they would like to get more information, then they will be able to select the Work Order on the map directly and open that Work Order to see more information.

Work Order Detail Screen:

Field personnel will see a form with details and the work required to be completed, and where they will complete the Work Order.

The Work Order screen is taken from the original paper Work Order that is filled in the field, in order to make the field personnel familiar with the screen.

The Work Order screen will allow the field personnel to add comments, meter reading and to complete the Work Order.

Routing Capability, Booking Hours and Grouping Forms based on the users are also included in this project.

Fees and conditions attached.

ATTACHMENT

COSTS:

Annual GeoViewer Online Hosting Fee.....	\$20,000 per year (Unlimited licenses)
Annual GeoViewer Mobile (iPad) Hosting Fee	\$20,000 per year (Unlimited licenses)
Annual Infor Integration and Hosting Fee.....	\$20,000 per year (5 years contract)
Annual Springbrook Integration and Hosting Fee.....	\$20,000 per year (5 years contract)

Note:

- Annual hosting fee for GeoViewer Online and Mobile also includes the 15 minor data changes/updates per month.
- Any revisions to Work Order forms is also included as part of Infor integration and hosting fee.

GIS DATA CONVERSION SERVICES (DATA UPDATE) COSTS

- a) Single services or hydrants - Nobel can add individual services, laterals, hydrants, blow offs, or similar features that can be drawn on an 8 1/2 X 11 sheet for the price of \$69 per sheet and 11 X 17 sheet at a cost of \$99 per sheet.
- b) Tentative Tracts / Asbuilts – Subdivision plan and profile drawings on large-scale sheets shall be imaged and drawn into the system and database at a cost of \$169 per sheet and the revisions to the Asbuilts at a cost of \$69 per sheet.
- c) Reservoirs, Pump Stations or other features shall be added to the system as needed and the cost will be determined based on the size of the project.
- d) Easements shall be added to the system through a COGO entry using the easement dimensioning descriptions, imaged, and added to the databases for \$35 per easement document.
- e) Printing of Atlas Sheets: Whenever the GIS data has been modified, Nobel Systems create the updated 11 x 17" Atlas sheets with the data sheets in the back of the graphic sheet and Nobel Systems will charge \$3.00 / sheet.
- f) Hourly costs for time and material based work
 - a) Project Director - \$150 per hour
 - b) Project Manager - \$130 per hour
 - c) System Architect - \$130 per hour
 - d) Senior Application Developer - \$100 per hour

- e) Senior GIS Analyst - \$100 per hour
- f) Bangalore Support services - \$50 per hour



POLICY NUMBER: BKW56444636

COMMERCIAL GENERAL LIABILITY
CG 20 10 04 13

THIS ENDORSEMENT CHANGES THE POLICY. PLEASE READ IT CAREFULLY.

**ADDITIONAL INSURED - OWNERS, LESSEES OR
CONTRACTORS - SCHEDULED PERSON OR
ORGANIZATION**

This endorsement modifies insurance provided under the following:

COMMERCIAL GENERAL LIABILITY COVERAGE PART

SCHEDULE

Name Of Additional Insured Person(s) Or Organization(s):

Blanket Additional Insured agreed

436 E VANDERBILT WAY

SAN BERNARDINO, CA 92408

Location(s) Of Covered Operations

436 E VANDERBILT WAY, SAN BERNARDINO, CA-92408

Information required to complete this Schedule, if not shown above, will be shown in the Declarations.

A. Section II - Who Is An Insured is amended to include as an additional insured the person(s) or organization(s) shown in the Schedule, but only with respect to liability for "bodily injury", "property damage" or "personal and advertising injury" caused, in whole or in part, by:

1. Your acts or omissions; or
2. The acts or omissions of those acting on your behalf;

in the performance of your ongoing operations for the additional insured(s) at the location(s) designated above.

However:

1. The insurance afforded to such additional insured only applies to the extent permitted by law; and
2. If coverage provided to the additional insured is required by a contract or agreement, the insurance afforded to such additional insured will not be broader than that which you are required by the contract or agreement to provide for such additional insured.

B. With respect to the insurance afforded to these additional insureds, the following additional exclusions apply:

This insurance does not apply to "bodily injury" or "property damage" occurring after:

1. All work, including materials, parts or equipment furnished in connection with such work, on the project (other than service, maintenance or repairs) to be performed by or on behalf of the additional insured(s) at the location of the covered operations has been completed; or
2. That portion of "your work" out of which the injury or damage arises has been put to its intended use by any person or organization other than another contractor or subcontractor engaged in performing operations for a principal as a part of the same project.

- C. With respect to the insurance afforded to these additional insureds, the following is added to Section III - Limits Of Insurance:**

If coverage provided to the additional insured is required by a contract or agreement, the most we will pay on behalf of the additional insured is the amount of insurance:

- 1. Required by the contract or agreement;
or**
- 2. Available under the applicable Limits of Insurance shown in the Declarations;**

whichever is less.

This endorsement shall not increase the applicable Limits of Insurance shown in the Declarations.

POLICY NUMBER: BKW56444636

COMMERCIAL GENERAL LIABILITY
CG 20 37 04 13

THIS ENDORSEMENT CHANGES THE POLICY. PLEASE READ IT CAREFULLY.

**ADDITIONAL INSURED - OWNERS, LESSEES OR
CONTRACTORS - COMPLETED OPERATIONS**

This endorsement modifies insurance provided under the following:

COMMERCIAL GENERAL LIABILITY COVERAGE PART
PRODUCTS/COMPLETED OPERATIONS LIABILITY COVERAGE PART

SCHEDULE

Name Of Additional Insured Person(s) Or Organization(s)
Blanket Additional Insured agreed

436 E VANDERBILT WAY

SAN BERNARDINO, CA 92408

Location And Description Of Completed Operations
Work described in writing in the contract,
agreement or permit."

Location (s) at which You performed work described
in written contract, agreement or permit.

Information required to complete this Schedule, if not shown above, will be shown in the Declarations.

A. Section II - Who Is An Insured is amended to include as an additional insured the person(s) or organization(s) shown in the Schedule, but only with respect to liability for "bodily injury" or "property damage" caused, in whole or in part, by "your work" at the location designated and described in the Schedule of this endorsement performed for that additional insured and included in the "products-completed operations hazard".

However:

1. The insurance afforded to such additional insured only applies to the extent permitted by law; and
2. If coverage provided to the additional insured is required by a contract or agreement, the insurance afforded to such additional insured will not be broader than that which you are required by the contract or agreement to provide for such additional insured.

B. With respect to the insurance afforded to these additional insureds, the following is added to Section III - Limits Of insurance:

If coverage provided to the additional insured is required by a contract or agreement, the most we will pay on behalf of the additional insured is the amount of insurance:

1. Required by the contract or agreement; or
2. Available under the applicable Limits of Insurance shown in the Declarations; whichever is less.

This endorsement shall not increase the applicable Limits of Insurance shown in the Declarations.

POLICY NUMBER: BKW56444636

COMMERCIAL GENERAL LIABILITY
CG 24 04 05 09

**WAIVER OF TRANSFER OF RIGHTS OF RECOVERY
AGAINST OTHERS TO US**

This endorsement modifies insurance provided under the following:

COMMERCIAL GENERAL LIABILITY COVERAGE PART
PRODUCTS/COMPLETED OPERATIONS LIABILITY COVERAGE PART

SCHEDULE

Name Of Person Or Organization:

"As required by written contract or agreement
entered into before loss."

436 E VANDERBILT WAY,

SAN BERNARDINO, CA-92408

Information required to complete this Schedule, if not shown above, will be shown in the Declarations.

The following is added to Paragraph 8. Transfer
Of Rights Of Recovery Against Others To Us of
Section IV - Conditions:

We waive any right of recovery we may have
against the person or organization shown in the
Schedule above because of payments we make
for injury or damage arising out of your ongoing
operations or "your work" done under a contract
with that person or organization and included in
the "products-completed operations hazard".
This waiver applies only to the person or organi-
zation shown in the Schedule above.

POLIC : BKW56444636

COMMERCIAL GENERAL LIABILITY
CG 89 98 04 12

THIS ENDORSEMENT CHANGES THE POLICY. PLEASE READ IT CAREFULLY.

AMENDMENT OF OTHER INSURANCE CONDITION

This endorsement modifies insurance provided under the following:

COMMERCIAL GENERAL LIABILITY COVERAGE PART

A. The following is added to provision a. Primary Insurance of Paragraph 4. Other Insurance under Section IV - Commercial General Liability Conditions:

However, when an additional Insured has been added to this Coverage Part by attachment of an endorsement, we will not seek contribution from the "additional insured's own insurance" provided that:

- (1) You have agreed in a written contract that this insurance is primary and non-contributory; and
- (2) The "bodily injury" or "property damage" occurs, or the "personal and advertising injury" is committed, subsequent to the execution of such contract.

B. For the purposes of this endorsement the following is added to Section V - Definitions:

"Additional insured's own insurance" means other insurance for which the additional insured is designated as a Named Insured.



THIS ENDORSEMENT CHANGES THE POLICY. PLEASE READ IT CAREFULLY.

**WAIVER OF OUR RIGHT TO RECOVER FROM
OTHERS ENDORSEMENT - CALIFORNIA**

Policy Number: 72 WEC GE6312

Endorsement Number:

Effective Date: 04/26/16 Effective hour is the same as stated on the Information Page of the policy.

Named Insured and Address: NOBEL SYSTEMS INC

436 E VANDERBILT WAY
SAN BERNARDINO, CA 92408

We have the right to recover our payments from anyone liable for an injury covered by this policy. We will not enforce our right against the person or organization named in the Schedule. (This agreement applies only to the extent that you perform work under a written contract that requires you to obtain this agreement from us.)

You must maintain payroll records accurately segregating the remuneration of your employees while engaged in the work described in the Schedule.

The additional premium for this endorsement shall be 2 % of the California workers' compensation premium otherwise due on such remuneration.

SCHEDULE

Person or Organization

Job Description

"ANY PERSON OR ORGANIZATION
WRITTEN CONTRACT OR AGREEMENT
RIGHTS FROM US."

FROM WHOM YOU ARE REQUIRED BY
TO OBTAIN THIS WAIVER OF

Countersigned by _____

Authorized Representative

P : BAA56444636

COMMERCIAL AUTO
CA 88 10 01 13

THIS ENDORSEMENT CHANGES THE POLICY. PLEASE READ IT CAREFULLY.
BUSINESS AUTO COVERAGE ENHANCEMENT ENDORSEMENT

This endorsement modifies insurance provided under the following:

BUSINESS AUTO COVERAGE FORM

With respect to coverage afforded by this endorsement, the provisions of the policy apply unless modified by the endorsement.

COVERAGE INDEX

<u>SUBJECT</u>	<u>PROVISION NUMBER</u>
ADDITIONAL INSURED BY CONTRACT, AGREEMENT OR PERMIT	3
ACCIDENTAL AIRBAG DEPLOYMENT	12
AMENDED DUTIES IN THE EVENT OF ACCIDENT, CLAIM, SUIT OR LOSS	19
AMENDED FELLOW EMPLOYEE EXCLUSION	5
AUDIO, VISUAL AND DATA ELECTRONIC EQUIPMENT COVERAGE	13
BROAD FORM INSURED	1
BODILY INJURY REDEFINED	22
EMPLOYEES AS INSURED (including employee hired auto)	2
EXTENDED CANCELLATION CONDITION	23
EXTRA EXPENSE – BROADENED COVERAGE	10
GLASS REPAIR – WAIVER OF DEDUCTIBLE	15
HIRED AUTO PHYSICAL DAMAGE (including employee hired auto and loss of use)	6
HIRED AUTO COVERAGE TERRITORY	20
LOAN / LEASE GAP	14
PARKED AUTO COLLISION COVERAGE (WAIVER OF DEDUCTIBLE)	16
PERSONAL EFFECTS COVERAGE	11
PHYSICAL DAMAGE – ADDITIONAL TRANSPORTATION EXPENSE COVERAGE	8
RENTAL REIMBURSEMENT	9
SUPPLEMENTARY PAYMENTS	4
TOWING AND LABOR	7
TWO OR MORE DEDUCTIBLES	17
UNINTENTIONAL FAILURE TO DISCLOSE HAZARDS	18
WAIVER OF TRANSFER OF RIGHTS OF RECOVERY AGAINST OTHERS TO US	20

SECTION II – LIABILITY COVERAGE is amended as follows:

1. BROAD FORM INSURED

SECTION II – LIABILITY COVERAGE, paragraph A.1. –WHO IS AN INSURED is amended to include the following as an insured:

d. Any legally incorporated entity of which you own more than 50 percent of the voting stock during the policy period. However, "insured" does not include any organization that:

- (1) Is a partnership or joint venture; or
- (2) Is an insured under any other automobile policy; or
- (3) Has exhausted its Limit of Insurance under any other automobile policy.

Paragraph d. (2) of this provision does not apply to a policy written to apply specifically in excess of this policy.

e. Any organization you newly acquire or form, other than a partnership or joint venture, of which you own more than 50 percent of the voting stock. This automatic coverage is afforded only for 180 days from the date of acquisition or formation. However, coverage under this provision does not apply:

- (1) If there is similar insurance or a self-insured retention plan available to that organization;

- (2) If the Limits of Insurance of any other insurance policy have been exhausted; or
- (3) To "bodily injury" or "property damage" that occurred before you acquired or formed the organization.

2. EMPLOYEES AS INSURED

SECTION II – LIABILITY COVERAGE, paragraph A.1. –WHO IS AN INSURED is amended to include the following as an insured:

- f. Any "employee" of yours while using a covered "auto" you do not own, hire or borrow, but only for acts within the scope of their employment by you. Insurance provided by this endorsement is excess over any other insurance available to any "employee".
- g. An "employee" of yours while operating an "auto" hired or borrowed under a written contract or agreement in that "employee's" name, with your permission, while performing duties related to the conduct of your business and within the scope of their employment. Insurance provided by this endorsement is excess over any other insurance available to the "employee".

3. ADDITIONAL INSURED BY CONTRACT, AGREEMENT OR PERMIT

SECTION II – LIABILITY COVERAGE, paragraph A.1. –WHO IS AN INSURED is amended to include the following as an insured:

- h. Any person or organization with respect to the operation, maintenance or use of a covered "auto", provided that you and such person or organization have agreed in a written contract, agreement, or permit issued to you by governmental or public authority, to add such person, or organization, or governmental or public authority to this policy as an "insured".

However, such person or organization is an "insured":

- (1) Only with respect to the operation, maintenance or use of a covered "auto";
- (2) Only for "bodily injury" or "property damage" caused by an "accident" which takes place after you executed the written contract or agreement, or the permit has been issued to you; and
- (3) Only for the duration of that contract, agreement or permit

4. SUPPLEMENTARY PAYMENTS

SECTION II – LIABILITY COVERAGE, Coverage Extensions, 2.a. Supplementary Payments, paragraphs (2) and (4) are replaced by the following:

- (2) Up to \$3,000 for cost of bail bonds (including bonds for related traffic violations) required because of an "accident" we cover. We do not have to furnish these bonds.
- (4) All reasonable expenses incurred by the insured at our request, including actual loss of earnings up to \$500 a day because of time off from work.

5. AMENDED FELLOW EMPLOYEE EXCLUSION

In those jurisdictions where, by law, fellow employees are not entitled to the protection afforded to the employer by the workers compensation exclusivity rule, or similar protection, the following provision is added:

SECTION II – LIABILITY, exclusion B.5. FELLOW EMPLOYEE does not apply if the "bodily injury" results from the use of a covered "auto" you own or hire.

SECTION III – PHYSICAL DAMAGE COVERAGE is amended as follows:

6. HIRED AUTO PHYSICAL DAMAGE

Paragraph A.4. Coverage Extensions of SECTION III – PHYSICAL DAMAGE COVERAGE, is amended by adding the following:

If hired "autos" are covered "autos" for Liability Coverage, and if Comprehensive, Specified Causes of Loss or Collision coverage are provided under the Business Auto Coverage Form for any "auto" you own, then the Physical Damage coverages provided are extended to "autos":

- a. You hire, rent or borrow; or

To the extent possible, notice to us should include:

- (1) How, when and where the "accident" or "loss" took place;
- (2) The "insureds" name and address; and
- (3) The names and addresses of any injured persons and witnesses.

20. WAIVER OF TRANSFER OF RIGHTS OF RECOVERY AGAINST OTHERS TO US

SECTION IV – BUSINESS AUTO CONDITIONS, paragraph A.5., Transfer of Rights of Recovery Against Others to Us, is amended by the addition of the following:

If the person or organization has waived those rights before an "accident" or "loss", our rights are waived also.

21. HIRED AUTO COVERAGE TERRITORY

SECTION IV – BUSINESS AUTO CONDITIONS, paragraph B.7., Policy Period, Coverage Territory, is amended by the addition of the following:

- f. For "autos" hired 30 days or less, the coverage territory is anywhere in the world, provided that the insured's responsibility to pay for damages is determined in a "suit", on the merits, in the United States, the territories and possessions of the United States of America, Puerto Rico or Canada or in a settlement we agree to.

This extension of coverage does not apply to an "auto" hired, leased, rented or borrowed with a driver.

SECTION V – DEFINITIONS is amended as follows:

22. BODILY INJURY REDEFINED

Under SECTION V – DEFINITIONS, definition C. is replaced by the following:

"Bodily injury" means physical injury, sickness or disease sustained by a person, including mental anguish, mental injury, shock, fright or death resulting from any of these at any time.

COMMON POLICY CONDITIONS

23. EXTENDED CANCELLATION CONDITION

COMMON POLICY CONDITIONS, paragraph A.– CANCELLATION condition applies except as follows:

If we cancel for any reason other than nonpayment of premium, we will mail to the first Named Insured written notice of cancellation at least 60 days before the effective date of cancellation. This provision does not apply in those states which require more than 60 days prior notice of cancellation.



INFORMATION

BOARD OF DIRECTORS

July 26, 2016

SUBJECT

QUARTERLY STRATEGIC PLAN OBJECTIVES AND GOALS UPDATE

DESCRIPTION

The Strategic Plan serves as a practical document used as a roadmap for the future direction of the District. Within the Key Focus Areas of the Strategic Plan are a series of Objectives that were defined by the Board and are used to guide staff in our activities. As stated in this document the Board of Directors will review the progress that the District is making on these Objectives on a regular basis to ensure that the District remains on track to achieve these Objectives.

The attached worksheets provided give a detailed breakdown of the Goals and Objectives for each of the six focus areas, defines the successes, accomplishments, and statuses for each focus area and the associated goals. As discussed during the approval of the Strategic Plan earlier this year, the Board will review the Strategic Plan in its entirety in the budgeting process in early 2017.

A presentation of this information will be given at the Board meeting.

POLICY

N/A

FISCAL IMPACTS

N/A

A handwritten signature in black ink, appearing to read 'Tom Kennedy', is written over a horizontal line.

Tom Kennedy
General Manager

07/26/16

Rainbow Municipal Water District

Strategic Plan Goals and Objectives for February 2016 to June 2017

Strategic Focus Area	Description	Assigned To	Estimated Completion	% Complete as of 07/01/2016	Comments	Measurement of Success
1	Water Resources					
1A	Complete Feasibility Study on Water Reclamation Plant	Engineering	7/1/2016	90%	Final report on feasibility of WRP and detailed Recycled distribution system submitted and under review.	Complete report in consultation with Engineering Committee.
1B	Complete Feasibility Study on San Luis Rey Groundwater	Engineering	3/1/2016	90%	Final report submitted. Review and comments and model formatting need to be addressed	Complete report in consultation with Engineering Committee.
1B.1	Initiate recommended "next steps" from SLR study	Engineering	10/1/2016	10%	Feasibility study lays out next steps	Complete Siting studies for well locations and treatment studies outlined in report. Coordinate with VCMWD and FPUD about potential project cooperation. Take steps to secure water rights.
1C	Initial the formation of a Groundwater Sustainability Agency	GM	9/1/2016	50%	Working on an exemption from the need to form GSA - should have information by 6/1/16	Coordinate with San Luis Rey MWD to either form the GSA or get SWRCB to agree that none is needed.

Rainbow Municipal Water District

Strategic Plan Goals and Objectives for February 2016 to June 2017

Strategic Focus Area	Description	Assigned To	Estimated Completion	% Complete as of 07/01/2016	Comments	Measurement of Success
2	Asset Management					
2A	Implement Asset Management System					See sub-objectives
2A.1	Procure Asset Management Software	GM	3/1/2016	100%	Completed	Procurement complete and system available for use.
2A.2	Configure Asset Management Software	GM	5/1/2016	100%	Ready for Asset Uploads	Develop asset model framework and basic reporting functions. Identify and configure data exchanges protocols with other software systems. Initiate user training.
2A.2	Develop Asset inventory	GM/All	7/1/2016	71%	Asset Uploads in progress	Capture required data for at least 95% of assets and enter into software.
2A.3	Initiate use of Asset Management System on day to day basis	GM/All	10/1/2016	25%	Timecard export functions in process	Commence process of moving users onto the system, group by group.
2A.4	Complete transition to use of Asset Management System	All	3/1/2017	10%	workstation setup in process	Complete process by having all employees using the system on a daily basis.
2B	Document asset condition through continuous condition assessment	All	Ongoing			To be accomplished through the EAM.
2B.1	Develop a Condition Assessment program	Engineering	10/1/2016	15%	Masters plan complete. Asset data inputted with installation dates to provide baseline for condition assessment program	In accordance with the recommendations of the Master Plan, create a Condition Assessment Program. This program should identify critical infrastructure that requires assessment and methods to get the data.
2C	Develop long-term asset rehabilitation schedules	Engineering	3/1/2017	10%	Master plans complete which provides the basis of some replacement projects in the Capital Improvement Program	Based on Master Plan and Condition Assessment Program develop schedules, including cost estimates, of future asset replacement projects.

Rainbow Municipal Water District

Strategic Plan Goals and Objectives for February 2016 to June 2017

Strategic Focus Area	Description	Assigned To	Estimated Completion	% Complete as of 07/01/2016	Comments	Measurement of Success
3	Workforce Management					
3A	Maintain education and training opportunities to ensure continuous improvement and learning for all staff.					See sub-objectives
3A.1	Arrange for at least one ACWA/JPIA Professional Development Training for Crew Leaders, UWIII's and Superintendents	HR	12/1/2016	33%	HR Manager, Operations Manager, Safety Administrator and 2 Superintendents are attending ACWA JPIA training day on July 20/21. UIII's and Crew Leaders TBD	Completion of training sessions with at least 85% attendance from named groups.
3A.2	Attend HR/Safety Workshops through SDRMA - at least one HR, superintendent, one manager, safety administrator, and/or GM	HR	4/1/2016	100%	Completed	Completion of training sessions with at least 50% attendance for named groups to be held in Newport Beach .
3A.3	Promote tuition reimbursement program to employees	HR	11/1/2016	25%	Several employees are enrolled in the Cal State San Marcos Water Management Certificate Program. Notifications of Semester enrollment at Palomar College and Mt. San Jacinto College to be sent with pre-approval form in July.	Perform a survey to identify any additional needs for the program and develop information to support next MOU negotiations.
3A.4	Conduct a class for Customer Service on dealing with customers effectively	HR	10/1/2016	20%	8 District employees have taken an online class. Currently evaluating other options and discussing with Finance Manager.	Course completed by at least 80% of department.
3A.5	Attend CSDA Conference - at least one HR, superintendent, one manager, safety administrator, and/or GM	HR/ALL	10/31/2016	10%	Operations Department currently working with H/R on scheduling staff to participate in this training on October (10th - 13th). To be 100% by this target date.	Attend conference with at least 50% attendance from named groups to be held in San Diego . Attendance qualifies us for discounts on premiums.
3A.6	Conduct performance evaluation training for superintendents and managers	HR	9/1/2016	10%	Coaching on individual basis pending outside training.	Quality performance evaluations enhance employee satisfaction and performance. Advanced training to be provided to all managers and superintendents.
3B	Develop a cross training program to help build internal capacity.	HR	10/1/2016	25%	The Operations Department and the Meter Department have a plan and schedule in place which employees are currently cross-training. This program is in the process of becoming formalized with H/R to ensure it meets its intended goals.	Develop a completed program that identifies the processes and controls to ensure that a cross training program meets its intended goals.
3C	Create a succession planning process to identify, assess and develop employees who exhibit potential.	HR	5/1/2016	10%	In progress - delayed due to staffing change (New HR Manager)	Conduct annual staffing analysis.

Rainbow Municipal Water District

Strategic Plan Goals and Objectives for February 2016 to June 2017

Strategic Focus Area	Description	Assigned To	Estimated Completion	% Complete as of 07/01/2016	Comments	Measurement of Success
3	Workforce Management					
3D	Implement cost effective employee recognition program to acknowledge performance, encourage development and improve morale.					See sub-objectives
3D.1	Employee Recognition Banquet	HR/GM	1/31/2017	40%	Event Committee is planning banquet. Pala Mesa Resort was selected as the site due to optimal pricing. REA is fundraising to offset the costs of guests to attend. DJ has been selected.	Conduct employee survey to get feedback regarding next event, conduct event planning committee meetings, secure approval from Board of Directors and select venue.
3D.2	Employee Anniversary Award Recognition	HR/GM	Ongoing	Ongoing	Ongoing	Recognize employees by years of service milestones as defined in the Admin. Code.
3D.3	Quarterly Employee Birthday Luncheon	HR	Ongoing	Ongoing	Next Birthday Luncheon is scheduled for August 4th.	Quarterly invitations are distributed to employees and lunch provided by District.
3D.4	Quarterly Employee Anniversary Break	HR/GM	Ongoing	Ongoing	Next Quarterly Anniversary Employee Appreciation Event is scheduled for September 8th.	Quarterly invitations are distributed to employees and invited to attend a break provided by the District with department heads and Board of Directors.
3D.5	Annual Employee Appreciation Lunch	HR/GM	6/30/2016	10%	Delayed due to change in HR Manager. Tentatively planned for late August.	Lunch provided by the District to show its appreciate to all employees. Attendance includes Board of Directors.
3E	Create a safety culture for the District workforce and promote safe work practices.					See sub-objectives
3E.1	Conduct mandatory internal and external safety training	HR/Safety	Ongoing	Ongoing	Operations in-compliance with all CAL-OSHA "hands-on" Safety Training Requirements. Implemented new tailgate training process to consistently deliver weekly to Operations.	Completion of training sessions with at least 85% attendance.
3E.2	Yearly Safety Recognition BBQ	HR/Safety	4/1/2016	100%	Completed	Recognize employees for years without injury and incident for the previous year.
3F	Ensure continuous Board development and participation in industry-related activities.					See sub-objectives
3F.1	At least one Board member to attend SDRMA workshop	HR	11/1/2016		October joint SDRMA Claims day with CSDA Conference enrollment now open. Time to select the Board Member to attend.	To be held in March in Newport Beach or in October in San Diego.
3F.2	At least one Board member to attend CSDA Annual Conference	HR	10/31/2016		Enrollment now open. Time to select attendees.	To be held in October in San Diego.
3F.3	At least one Board member to attend SDLA Conference	HR	7/31/2016		Rescheduled to February 2017 when this will be held in San Diego	To be held in Napa Valley.
3G	Conduct a salary/compensation survey					See sub-objectives
3G.1	Meet with bargaining units	HR/GM	5/1/2016		Delayed due to turnover of HR Manager	To discuss which comparable agencies to utilize in survey.
3G.2	Develop and issue an RFP	HR	6/1/2016	10%	In progress - HR Manager developing RFP for release in Fall 2016	Complete consultant selection process.
3G.3	Complete Salary Survey	HR/GM	2/1/2017		In progress - HR Manager developing RFP	Review submitted RFP's and select one that meets District's needs.

Rainbow Municipal Water District

Strategic Plan Goals and Objectives for February 2016 to June 2017

Strategic Focus Area	Description	Assigned To	Estimated Completion	% Complete as of 07/01/2016	Comments	Measurement of Success
4	Fiscal Responsibility					
4A	Develop Budgets in compliance with GFOA standards					See sub-objectives
4A.1	Complete evaluation of budgeting process to identify where improvements are needed to meet GFOA standards	Finance	5/1/2016	100%	Re-formatted entire Budget to adhere to GFOA budgeting criteria.	When complete, this will include a document identifying the steps needed to achieve GFOA compliance.
4A.2	Develop a GFOA compliant budget and submit budget for consideration for the GFOA Distinguished Budget Presentation Award	Finance	7/31/2016	90%	Budget completed in process for submission to GFOA.	By the end of this process a budget format will be developed and the budget document completed in a GFOA compliant manner.
4B	Update appropriate reserve and investment policies to protect customers				Will begin reviewing industry standards, and or other agencies policies to see what best meets District's objectives.	See sub-objectives
4B.1	Review current policies with Budget and Finance Committee and develop recommendations for Board consideration	Finance	10/31/2016	5%	In progress	When complete, this objective will provide a comprehensive review of current policies as well as some suggested revisions for Board consideration.
4B.2	Present revised reserve and investment policies to the Board for consideration and implementation	Finance	12/31/2016			If policies are approved by the Board they will be implemented within 45 days of approval.
4C	Proactively manage and maintain sustainable employee benefits					See sub-objectives
4C.1	Prepare a comprehensive review of current benefit costs in preparation for the 2017 labor negotiations complete with forecasts of future cost increases based on known variables	Finance	11/1/2016	10%	Will prepare preliminary analysis to Executive Management for review.	Finance Manager and HR Manager preparing preliminary analysis for review
4D	Implement a Continuous Improvement Process for all district operations					See sub-objectives
4D.1	Develop and present Management Guidelines for Quality Control Initiative (QCI) and commence management training	GM	4/30/2016	100%	Guidelines developed and presented to Management Team	This process will be to develop the management guidelines for the program and get the senior leadership team trained on its implementation.
4D.2	Create Quality Control Committee consisting of management and employees and kick off detailed departmental QA/QC planning	GM/All	7/1/2016	10%	Ongoing - Working with new HR manager	This process will include an introduction of the QCI for all employees and the selection of leaders within the group to help develop the specific QA/QC programs.
4D.3	Complete QCI program development and commence implementation of program	GM/All	1/1/2017	10%		This process will embed the Plan-Communicate-Do-Check and Document -Provide Feedback cycle that is the cornerstone of QA/QC programs. QC steps will be incorporated into EAM for record keeping and evaluation processes.
4E	Complete transition to new Financial Software System	Finance	9/1/2016	75%	Will do a parallel testing in early August. Go Live is scheduled for late August.	The legacy system from Datastream will be completely out of day-to-day use. Some reporting functions for past years may be retained for special purposes and/or audits for a few fiscal years.
4F	Obtain District of Distinction Accreditation	GM/All	6/30/2017		Training moved to February 2017 in San Diego - GM has joined Rotary to satisfy public service requirements	Meet all requirements and training and demonstrate having sound policies in the areas of governance, board conduct, district finances, transparency and reserves and submit application and supporting documentation in a timely manner.

Rainbow Municipal Water District

Strategic Plan Goals and Objectives for February 2016 to June 2017

Strategic Focus Area	Description	Assigned To	Estimated Completion	% Complete as of 07/01/2016	Comments	Measurement of Success
5	Customer Service					
5A	Complete feasibility studies for enhancing the delivery of information to customers through technologies such as Advanced Metering Infrastructure	Finance	12/31/2016	5%	In progress	Meet with various vendors offering AMI, select AMI system appropriate for District needs, conduct research on grant funding or other financial options.
5B	Expand options for customer on-line bill pay and timely account information	Finance	9/30/2016	50%	Looking at other payment options directly with Springbrook that will be real time data.	Conduct research by assessing what other local water districts are utilizing for their online bill pay options and what data is being presented on customer's online accounts. Also seek reputable vendors in the industry of online bill pay for latest technology being utilized. Engage with Springbrook to develop appropriate system.
5C	Enhance capabilities of field customer service staff through geographic dispatching and information systems.	Finance	12/31/2016	10%	In progress	Integrate GIS with Utility Billing software for field staff when responding to service/work orders to maximize time management. Identify and budget for appropriate devices for staff to use in the field.

Rainbow Municipal Water District

Strategic Plan Goals and Objectives for February 2016 to June 2017

Strategic Focus Area	Description	Assigned To	Estimated Completion	% Complete as of 07/01/2016	Comments	Measurement of Success
6	Communications					
6A	Expand public outreach, information and education					See sub-objectives
6A.1	Complete re-design of monthly customer bills	ADMIN	5/1/2016	50%	Project has been delayed due to delays in utility billing software system.	Work with Finance and Communications committees to identify desired information on bill and work through several options. Present final options for Board approval. Implement outreach effort to explain new format to customers.
6A.2	Publish one News Release per month	ADMIN	4/1/2016	100%	Ongoing	As described.
6A.3	Secure a booth at Avocado Festival and one other regional event per year	ADMIN	3/15/2016	50%	Applied for Avocado Festival booth but were not accepted. Working on Autumn Festival	Application w/photos and payment submitted and booth secured for the Avocado Festival April 17, 2016. Locate additional events of interest and secure participation.
6A.4	Enhance newsletter design and content	ADMIN	4/1/2016	100%	Completed	Work with Communications Committee to develop new design aesthetic and enhance content variety.
6A.5	Set up Speaker's Bureau and notify groups	ADMIN	6/1/2016	100%	Completed	Include information about Speaker's Bureau on website.
6B	Ensure that District website is a valuable resource that meets the needs of customers					See sub-objectives
6B.1	Improve FAQ section	ADMIN	8/1/2016	10%	In Progress - currently working on the scripts and subject matter	Add videos on FAQ's and a list of things to know about customer's on-site water systems.
6B.2	Improve customer access to information about district activities and shutdowns	ADMIN	8/1/2016	100%	Completed	A special portion of the website will be developed to convey information for customers affected by shutdowns.
6C	Enhance education program in local school system					See sub-objectives
6C.1	Actively encourage participation in 4th Grade poster/calendar contest	ADMIN	11/13/2015 - 07/01/16	100%	Completed	4th grade presentations will have been made, entries collected and judged by employees and turned into VWD, winners invited to board meeting for awards presentation, and magnets of winning artwork will have been created and placed on trucks.
6C.2	Connect with local high school to partner with on conservations programs/events	ADMIN	1/19/2016	100%	Completed	Make contact with teachers/Administrators and identify areas where our information will mesh with their programs - conduct at least two high school events per year.
6D	Implement district facility tours for interested members of the public					See sub-objectives
6D.1	Create waiver forms for public attendees	ADMIN	8/1/2016		We will be starting work in July to complete and send to legal for review in August	Waiver form submitted to legal and approved form ready for first event.
6D.2	Set up quarterly tours	ADMIN	10/1/2016		Once waiver is approved we will set up a schedule, prepare staff and update website with details and implement public outreach	Prepared staff and selected facilities. Created schedule of events, sent out invitations, and posted on website.
6E	Improve communications between Board advisory committees and Board of Directors	ADMIN	Ongoing		Budget and Finance occurred May 24, 2016 - Engineering is scheduled for August, 2016 and Communications for October, 2016	Set up annual joint meetings for each committee (1 per 4 months).

MEETINGS/SEMINARS/CONFERENCES/WORKSHOPS

VARIABLE

DATE	2016	MEETING	LOCATION	ATTENDEES	POST
August	11	SDCWA Special Board Meeting	SDCWA	GM	N/A
August	*	CSDA – San Diego Chapter	(Location to be Announced) 6:00 p.m.	GM	N/A
August	*	LAFCO Special Meeting	County Admin Center, Room 358 – 9:30am	Sanford (As Advised by GM)	N/A
August	*	Santa Margarita Watershed Council	Rancho California Water District	Sanford	N/A

* To Be Announced

MEETINGS/SEMINARS/CONFERENCES/WORKSHOPS

RECURRING					
DATE	2016	MEETING	LOCATION	ATTENDEES	POST
August	1	LAFCO	County Admin. Center Room 358 9:00 am	Sanford (As Advised by GM)	N/A
August	1	Communications Committee Mtg.	RMWD Board Room 3:30 p.m.	Appointed Director, General Manager	7/28
August	3	Engineering Committee Meeting	RMWD Board Room 3:00 p.m.	Appointed Director, General Manager	7/28
August	9	Budget & Finance Committee Mtg.	RMWD Board Room 1:00 p.m.	Appointed Director, General Manager	7/28
August	15	NC Managers	Golden Egg 7:45 a.m.	General Manager	N/A
August	16	Council of Water Utilities	Stoneridge Country Club 7:15 a.m. Poway	All Directors, General Manager	7/11
August	19	LAFCO Advisory Committee	LAFCO, 9335 Harzard Way, 9:30 a.m.	General Manager	N/A
August	19	SDCWA GM's Meeting	SDCWA, San Diego 9:30 a.m.	General Manager	N/A
August	22	San Luis Rey Watershed Council	Fallbrook Public Utility District 1:00 p.m.	Walker	N/A
August	23	RMWD General Board	RMWD Board Room (Start Time to Be Determined)	All Directors	7/15
August	24	North County Water Group	Rincon Del Diablo, Escondido 7:30 a.m.	All Directors on a Rotating Schedule, General Manager	N/A
August	25	SDCWA Full Board Meeting	SDCWA Board Room, 3-5 p.m.	General Manager	N/A

June 30, 2016

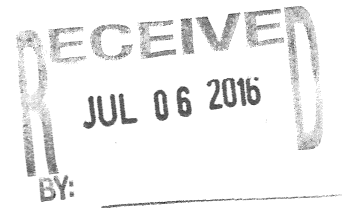

Qui & Ai Chau Do
XXXXXXXXXXXXXXXXXX
XXXXXXXXXXXXXXXXXX

Dear Board of Directors:

We wrote to you in December 2015 to protest the water rate increases and spoke at the meeting to voice our opposition. Unfortunately, the initiative passed with only 17 opposition letters received out of 8,600 parcels as conveyed at the meeting. As we stated in the letter below, we live on a large tract of land that comes with a 2" meter which we don't utilize. We don't have any agricultural operations and can no longer afford to pay the outrageously expensive meter fees which are unjustly based on the water meter size. All of our operations ceased to exist after the devastating fire in 2007, yet we continue to pay because we thought it the right thing to do. We are naïve because our next door neighbors/investors at APN 108-350-2300 said they complained and didn't have to pay since 2007. Conservatively using \$200 per month over the past 9 years, they have successfully avoided paying over \$22,000 in fixed charges that we had to pay. This is a clear example of subsidizing other property owners, and we have financially suffered as a consequence of your disparate practices. In a recent conversation with that neighbor, they are still not paying anything and don't think that their 2" water meter has been removed. If these neighbors and others have been receiving that kind of benefits, then we are requesting a refund of the fixed charges that we have been paying for the past 9 years!!!

We have raised the fix charge issue with the water district representatives and met with General Manager Kennedy who mentioned that our situation is unique since there are a small numbers of parcels in our meter class, which again reinforces the unfairness for us and those in similar circumstance who are burdened with significantly huge cost based on meter size and not usage. Mr. Kennedy suggested a smaller size water meter. However, we learned that we would have to pay over \$1,000 to downsize from a 2" to 1" meter and would have to pay over \$41,000 if we revert back to a 2" meter. We paid for a 2" meter as part of the cost of the land, which now cost over \$60,000. It doesn't make any sense to give up the meter we paid for under your current policy. We were told that we are paying for the capacity. If you look at our history since 2003, when we have the trees, our usage has been way under your designated capacity. For the past two years, our monthly usage has averaged around 80 units.

We have given you notice before that the fixed charges are not fair, which have since increased to \$305.39 per month. We can no longer support that payment since we don't have any agricultural businesses. We are willing to pay for the commodity/unit fees and fixed charges based on the equivalent usage by other customers but not based on the 2"meter size. We have been very patient for a resolution, but none has been forthcoming. If you are unable to resolve this ongoing situation, we are forced to seek legal help.

Sincerely,

December 12, 2015

Dear Board of Directors:

Subject: Opposition to the current and proposed water and pass-through increases
Service Address: XXXXXXXXXXXXXXXXXXXXXXX

We are writing to protest the proposed SDCWA Fixed Charge and Rainbow Municipal Water District Fixed Operations and Maintenance (RMWD Fixed O&M), both of which are established on the basis of the water meter size of the parcel of property receiving water service. We do not believe that the proposed rate structure provides a fair and equitable allocation of costs to customer classes and fails to meet the requirements of Proposition 218, which specify that property-related fees, such as water service fees, shall not exceed the proportional cost of providing the service attributable to a parcel.

We have been a rate payer in the District for almost 20 years and are compelled to speak out against this new round of rates increases which are detrimental to our livelihood. Let's us share our history with you. We purchased our property in 1996 which came with an existing 2" water meter and several acres of citrus and avocado trees. In 2003, we built a 1,200 square foot residence for a family of three so we can live onsite to manage and grow our agricultural operations. Over the years, the profits were eroded by rising costs. Then, in 2007, the devastating Rice Canyon fires inflicted severe damages to the majority of our trees. Afterward, we couldn't afford to take the risk to replant because the water rates keep going higher and higher, and we won't be able to keep the trees alive. We are small farmers who are trying to make an honest living. The drought, rising water cost, additional regulations, and bureaucracy have made it near impossible for small farmers to compete and are forcing us out-of-business.

Currently, we have about an acre of agricultural use under minimum irrigation. We are doing our part to conserve water and have significantly reduced our water consumption as mandated. Still, we are paying \$124.05 for RMWD Fixed O&M, and \$91.44 for MWD/SDCWA Fixed. The proposed RMWD Fixed O&M is \$214.45, an increase of \$90.40 or by 73%. The proposed SDCWA Fixed for (TSAWR Domestic) is essentially the same. Therefore, we would go from paying \$215.48 to \$305.89 per month for just these two fixed costs before using a drop of water. This is beyond outrageous!!! The water rates are already too high, making it unaffordable to grow anything. How are we going to pay for the increase? You are pushing us to the edge of the cliff!

The potable water cost of service study that your consultant provided indicated that larger meters impose larger demands than smaller meters. We question the usage assumptions from the study

and fairness based on Proposition 218. We feel it is highly unfair when we are paying the same fixed costs as our neighbors, whose properties also have 2” water meters, use plenty of water to irrigate thousands of avocado trees. In contrast, another neighbor with the same meter size said that they are not paying any monthly fees since they are not using any water. By paying a higher fixed fee for potential meter capacity, we are subsidizing the costs of both paying and non-paying customers with the same size meter. Over the past two years, our monthly usage is approximately 80 units. What is the average usage for customers with 2” meter?

In summary, our concerns are that basing fixed fees by meter size fail Proposition 218’s proportionality test.

- It requires low water use customers to pay fixed costs for water they can potentially use in theory, but do not have the actual capacity to use.
- Low and high water use customers pay the same fixed fee but derive entirely different benefits from the system.
- The low water use customers’ fixed fees cover some of the fixed costs of the high water user, in effect subsidizing the other customers.

We don’t have income from agricultural now and are protesting both current and proposed rate increases. Water is the key component to our business. Without water, nothing will grow. The rate increases are driving us out-of-business and forcing us to abandon our home. We cannot afford the current costs, and the increases are out of the question. We have been subsidizing the fixed costs for others for almost 20 years and can no longer continue.

We thank you for your time, for your evaluation of our circumstances and concerns, and for the actions that you will take to ensure fair and equitable water rates.

Qui Do



STAFF TRAINING REPORT

ATTENDEES NAME(S):	Delia A. Rubio
TITLE OF TRAINING/CONFERENCE/WORKSHOP/CLASS:	Esri User Conference
DATE(S) ATTENDED:	June 29, 2016
AGENCY HOSTING TRAINING/CONFERENCE/WORKSHOP/CLASS:	Esri
LOCATION:	San Diego, CA

BRIEF DESCRIPTION:

The Esri User Conference had many presentations with various topics. I selected sessions that focused on related District topics. The guest speakers provided examples of how they were able to us GIS to improve data reporting, organizing and work efficiencies:

Adopting Esri Platform improves utility management practice - Fort Erwin Speaker pointed out how they migrated from the map book to a Platform with the use of mobile apps to identify new/existing facilities. They hired a consultant to assist in developing the Platform and ensured it was user friendly with limited fields displayed and pick-list choices to facilitate data inputs. He recommended using templates from ARCGIS Solutions.

Utility Sustainability through GIS - Virginia Speaker said they were able to improve their asset management by consolidating various departmental databases and spreadsheets by using GIS. They used a Utility Management template and tied it in with Regulatory Requirements.

Water Utilities Special Interest Group - Dead Meter Notification - Alabama Speaker said they automated the meter over/under reads by using a GIS table join with the billing system to pull the meter numbers with the readings using 3 months of info. Flagged meters would generate an email to their meter ops to investigate. This saved a lot of manual time and was more consistent and accurate. I felt this would be worth looking into, since our staff currently does this manually.

Enterprise GIS - Padre Dam WD uses an embedded web map where users zoom into the map showing all FH. Address is typed in and zooms to the location to find the nearest FH-ID. ID is inserted on the Construction Meter Application and submitted to cust service, although users still have to come in to pay the fee. This is a good idea for RMWD if our system would allow online payment along with the application submission.

Esri.com welcomes any new ideas - some future work includes: Water Tank Maintenance, Treatment Plant Template, 3D, Water Quality Tools Template and Storm Water.



BOARD INFORMATION

BOARD OF DIRECTORS

July 26, 2016

SUBJECT

Operations Report for June 2016

DESCRIPTION

Activities for Operations & Maintenance Division

CONSTRUCTION & MAINTENANCE:

The Valve Maintenance crew exercised a total of 253 valves this month, just below their average goal of 303 per month. The crew assisted with two (2) planned shutdowns for the Construction crews. They also performed maintenance of five (5) PRV stations.

The Construction and Maintenance crews repaired six (6) leaks and performed two (2) planned shutdowns. They repaired four (4) plug valves and the installation/repair of nine (9) appurtenances. The crews also maintained District easements and completed work at the District Yard.

The District's mechanic completed a total of 25 District vehicles with regular *scheduled* preventative maintenance and/or repairs. He also assisted with a coolant leak at Pump Station No. 1. The following maintenance and/or repairs were considered *unscheduled*:

- Vehicles with Emergency Repairs (6)
- Small Equipment (6)
- Off-Road Equipment /Trailers Repairs & Maintenance (2)
- Off-Road Equipment/Trailer Emergency Repairs (0)
- Large Vehicles Maintenance/Repairs (1)
- Large Equipment Emergency Repairs (1)
- Safety Recalls (2)

WATER OPERATIONS:

New radios at the Cement Tank and Beck Reservoir are ready to be programmed in July. This is to replace the degrading phone line at the tank and will give us more reliable communications.

SCADA Projects: Huntley Pump Station upgrade is still in progress, 90% completed. Connection 9 radio upgrade still in progress, 70% completed.

Work at Morro CL2 Station to add two additional injection pumps as backups is at 70% completion.

Two Request for Proposals (RFP) for Backflow Testing Services were received and the review process was started.

Monthly tank and reservoir cover inspections completed.

May 2016 Water Quality Monthly Report:

- 22 Routine samples
- 4 Disinfection byproducts samples
- 18 Nitrification samples
- 11 TDS/Chloride tests in southern zones
- 1 Water quality complaint (taste & odor, flushed dead-end line)

WASTEWATER:

Sanitary Sewer Overflows (SSO):

None reported for the month of June

Improvements:

Date: 06-28-2016

Lift Station #2 – Installed and tested budgeted emergency generator bypass control panel.

Re: This equipment serves as a redundancy backup power supply when SDG&E electrical power or current generator goes out. The District can temporarily install a portable generator to keep the sewage lift station operational, avoiding sanitary sewer overflows.

Sanitary Sewer Overflow (SSO) remediation for May 2016 overflow:

Upon confirmation with Vista Valley Country Club, the District Wastewater staff entered Vista Valley Country Club H.O.A. and proceeded in exposing all 37 Rainbow MWD sewer manholes on the golf course. Staff performed extensive Closed Circuit Televising (CCTV) inspections and cleared 2 feet perimeter along each manhole as well as repaired and raised three (3) buried lost manholes to grade, avoiding further maintenance problems.

Sewer Line Cleaning:

June 01, 2016 – June 31, 2016

Total: 2,061'

Location: Vista Valley Golf Course

Water Loss: 2,244 gallons used

High Frequency Cleaning:

Two locations:

- 1,410' Sewage Siphon lines (8" & 10")

- 629' Westmont Drive (8")

Water Loss: 1,496 gallons used

Manhole Inspections:

June 01, 2016 – June 31, 2016

Total: 85

**Repaired and exposed three (3) lost/buried manholes*

Locations: Vista Valley Country Club

CCTV:

June 01, 2016 – June 31, 2016

Vista Valley Golf Course, Knottwood Way & Sycamore Ranch

Total: 8,025'

SAFETY:

Safety Training:

- Annual First Aid CPR Recertification – 43 Employees Recertified
- Annual Hearing Tests – 20 Employees
- Global Harmonized System (GHS) Review – 35 Employees
- Heat Illness Refresher – 35 Employees

Tailgate Safety Meetings:

- Carpal Tunnel Syndrome
- Dangers of CO2, Health Effects
- Stretch Before Working
- Vehicle Safety

Target Solutions Safety Online Training:

- Water Industry Driving Safety
- Advanced Construction Safety (Mod 2)
- Advanced Construction Safety (Mod 3)
- Water Industry Hazard Communication

Darren S. Milner

Darren S. Milner
Operations Manager

7/26/16



BOARD INFORMATION

BOARD OF DIRECTORS

July 26, 2016

SUBJECT

Engineering Report for June 2016

DESCRIPTION

CAPITAL PROJECTS:

Gird to Monserate Hill (201045): Predesign report and 90% design plans were submitted. Staff is currently reviewing the plans.

Horse Creek Lift Station (200555): Developer is working on obtaining the permit from Army Corps of Engineers.

Highway 76 East Segment (201260): Contractor has installed 9,000 feet of 18" sewerline out of 10,300 feet. All of the four casings have been installed.

Lift Station 1 (201040): Staff is working on location regarding the site for the lift station before the siphon. 60% design submittal being reviewed for LS-1B and sewer line from LS-1 to LS-2.

Water and Wastewater Asset Cost and Capacity Fee Study (201663): Consultant presented a project overview at the Engineering Committing Meeting on June 1, 2016. The draft System Valuation and Capacity Fee Analysis reports are due by July 2016.

Water Reclamation Plant (WRP) & Recycled Water Distribution System (RWDS) (201672): Staff reviewing the draft WRP and RWDS Predesign report.

Wastewater Outfall Replacement (201266): Project on hold until further evaluation from the Master Plan and the WRP study.

OTHER PROJECTS:

Moosa Creek Mitigation Bank (201459): Staff working with Consultant on easements.

San Luis Rey Ground Water Sources (201446): Report finalized and being reviewed by staff and consultant.

DEVELOPER PROJECTS:

Golf Green Estates (90100): (near Lift Station 1): 94 SFR planned across from Bonsall Elementary School. The 12" and 10" sewer mains have been completed. Construction on the 8" waterline in Old River Road has begun.

Helling Hill Run (00000): 5 Lot Subdivision with 260 foot waterline extension. Plans approved.

Horse Ranch Creek Ridge (D.R. Horton - formally Campus Park, Passerelle) (90096): 850 WMs / 850 EDUs – Off of Highway 76 and Horse Ranch Creek Road. Plan check for units 1-4, wastewater, and water complete. Caltrans approved construction of forcemain and waterline in Highway 76. Project is under review with the Army Corps of Engineers and Pala Indians.

Malabar Ranch (90061): 31 WMs / 29 EDUs – There are 17 out of 31 homes built. Contractor shall complete waterline relocation and punch list items.

Nessy Burger (00000): Nessy Burger's is proposing to install a permanent building. Plan check one completed.

Olive Hill Estates (90066): 37 WMs / 59.2 EDUs – Contractor is working on completing above ground appurtenances. All meters have been installed except for the landscape irrigation meter. Contractor working on punchlist items.

Pala Mesa Highlands (90056): 124 Lots on Old Highway 395. Plan check three completed.

OTHER:

ITEMS	NO#	ITEMS	NO#
Water Availability Letters	1	Water Meters Purchased	0
Sewer Availability Letters	0	Sewer EDUs Purchased	3.4
Water Commitment Letters	0	Developer Shutdowns	0
Sewer Commitment Letters	0	Jobs Closed:	0



Michael Powers
Associate Engineer

7/26/16



BOARD INFORMATION

BOARD OF DIRECTORS

July 12, 2016

SUBJECT

Customer Service & Meter Services

DESCRIPTION

METER SERVICES:

Meter Services completed 584 service orders. Here is a summary of most of the service orders.

SERVICE ORDERS	COMPLETED
Check Reads	339
Transfers	104
Locked	13
Unlocked	15
Pressure Calls	38
Meter Leaks	32

CUSTOMER SERVICE:

On June 21, 2016 Customer Service & Meter Services helped out on a scheduled shutdown. Customer Service called and notified the customers of the scheduled shutdown. Meter Services shut the meters off before the water lines were shutdown. After the repair was done, and the water lines were filled Meter Services went back out and helped turn back on all the affected meters. Customers were very happy with the notification. It was a very smooth process.



 Vanessa Martinez
 Finance Manager
 7/12/16

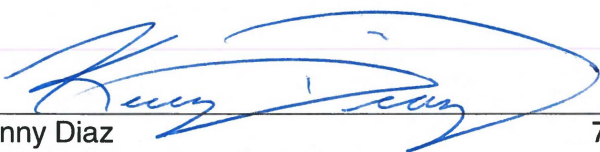

 Kenny Diaz
 Meter Services Crew Leader
 7/12/16



INFORMATION

BOARD OF DIRECTORS

July 26, 2016

SUBJECT

Changes in Personnel and Reporting

DESCRIPTION

The Human Resources Technician position was eliminated effective June 30, 2016.

Jeff Stacy, Safety Administrator is now reporting to Karleen Harp, Human Resources Manager, effective July 1, 2016.

Tammy Rakusan resigned her position as Accounting Specialist I, effective July 12. The position is currently vacant and we are accepting applications.

POLICY

N/A

FISCAL IMPACTS

N/A

Karleen Harp

Karleen Harp
Human Resources Manager

07/26/16

**RAINBOW MUNICIPAL WATER DISTRICT
ORGANIZATIONAL CHART
PAGE 1 OF 2**

Creation Date 8/21/2014

Last Modified 7/12/2016

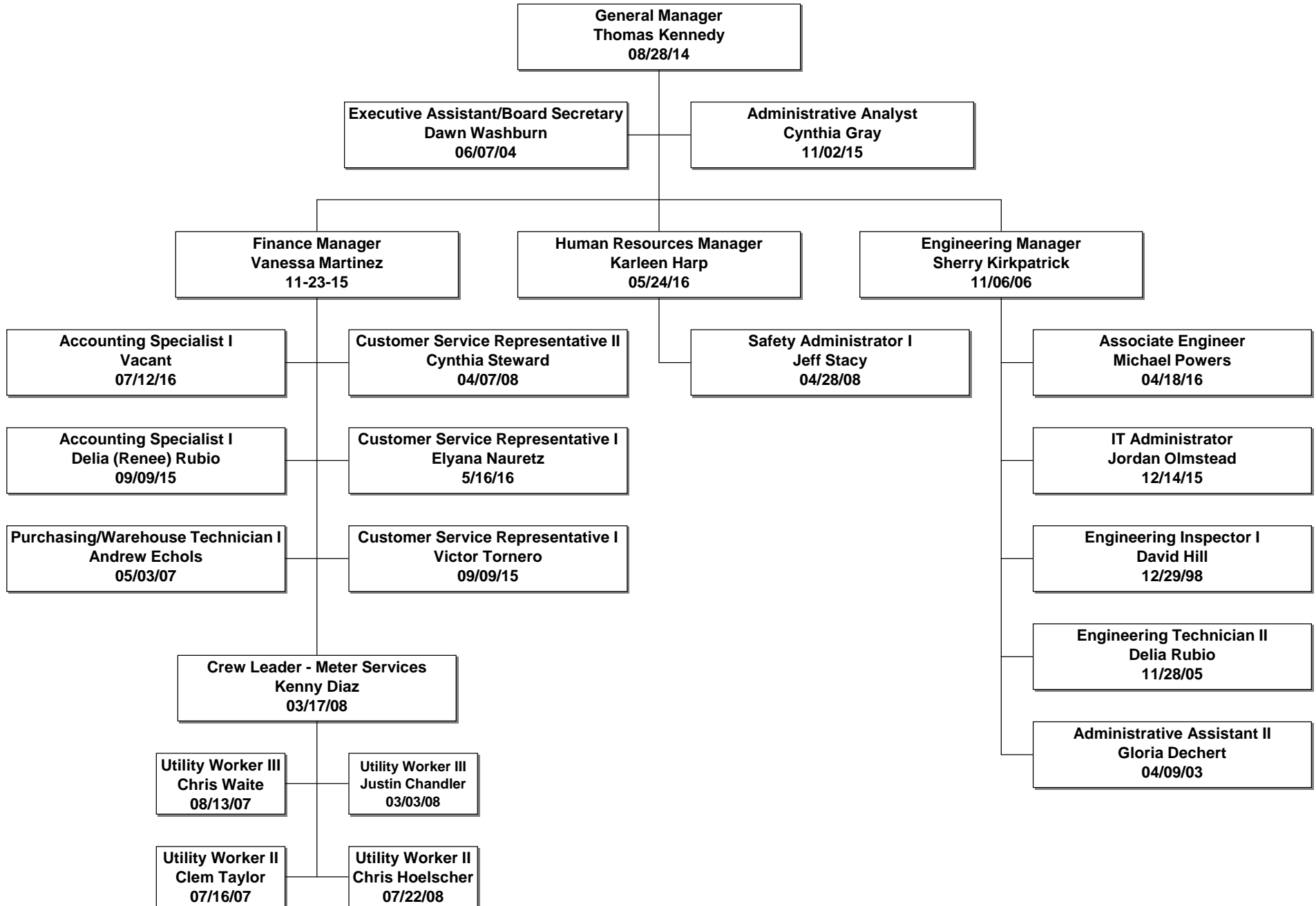

Creation Date 8/21/2014

Last Modified 7/12/2016

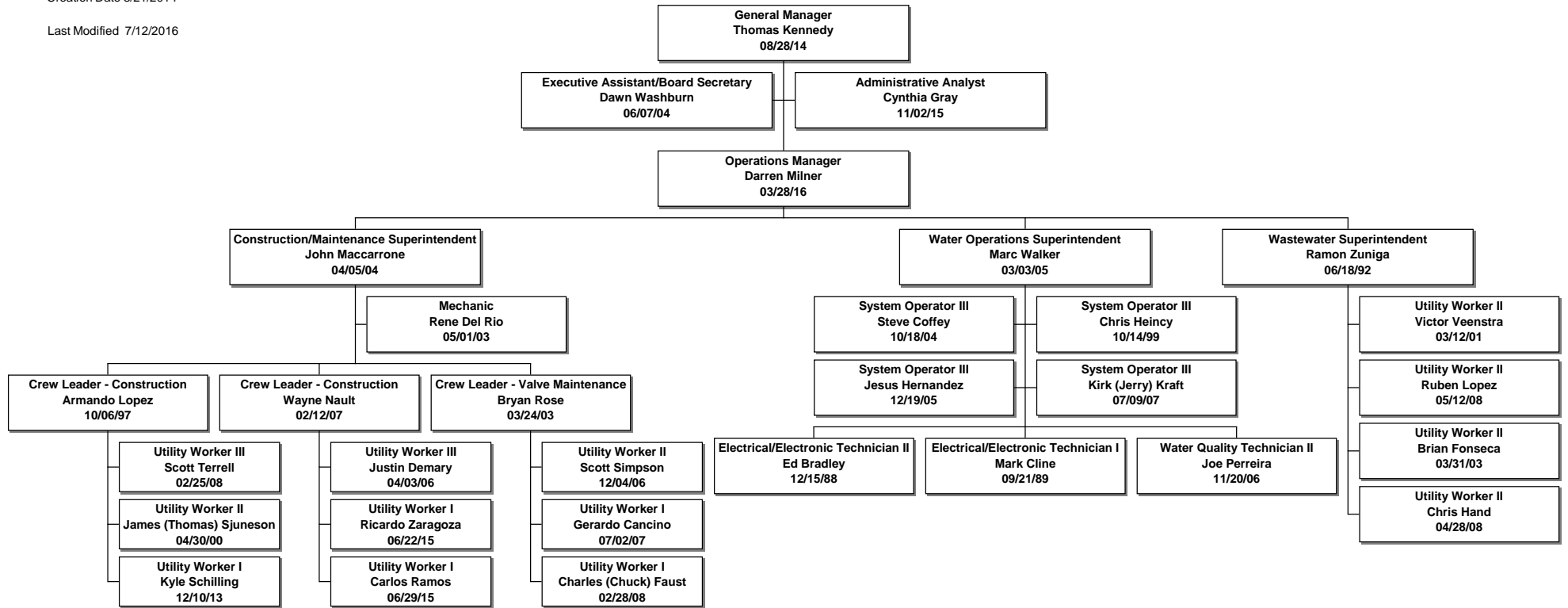

**RAINBOW MUNICIPAL WATER DISTRICT
ORGANIZATIONAL CHART**

Creation Date 8/21/2014

Last Modified 7/12/2016

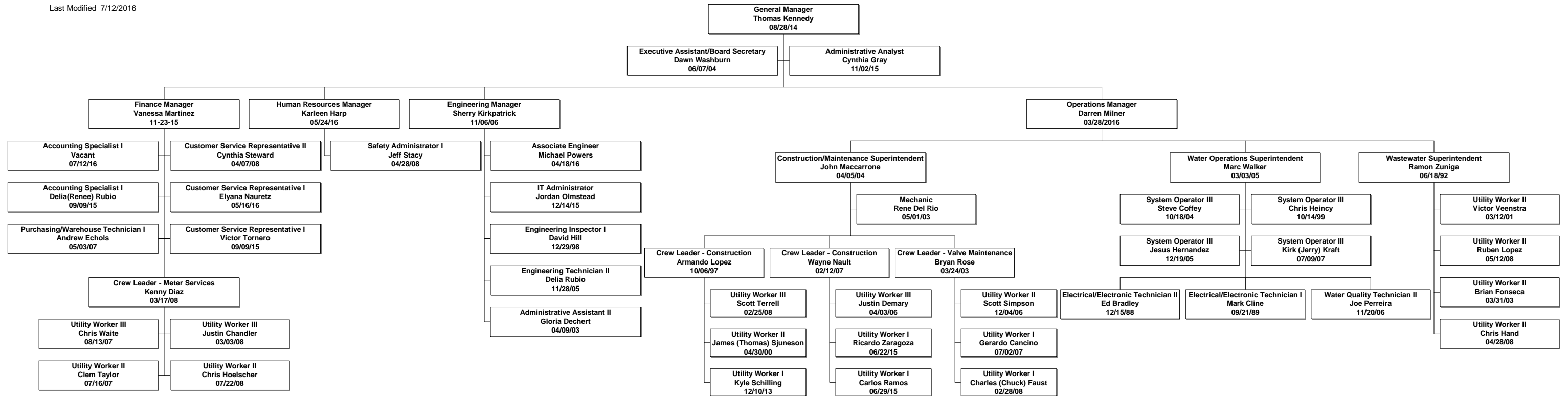

General Ledger

Interim Financials

User: vmartinez
 Printed: 7/14/2016 - 1:59 PM
 Period: 1 to 11, 2016



Account Number	Description	Budget Amount	Period Amount	YTD Amount	YTD Var	Encumbered Amount	Available	% Available
Fund 01	WATER FUND							
Dept 01-00								
R10	WATER REVENUE							
01-00-41110	Water Sales-Domestic	13,525,669.00	4,625,318.59	4,625,318.59	8,900,350.41	0.00	8,900,350.41	65.80
01-00-41115	Water Sales-Domestic-Unbilled	0.00	80,293.17	80,293.17	-80,293.17	0.00	-80,293.17	0.00
01-00-41120	Water Sales-Ag-Dom Non Cert	0.00	1,775,109.06	1,775,109.06	-1,775,109.06	0.00	-1,775,109.06	0.00
01-00-41125	Water Sales-Ad Noncert Unbilld	0.00	-105,368.15	-105,368.15	105,368.15	0.00	105,368.15	0.00
01-00-41130	Water Sales-Ag/Dom Met Cert	0.00	0.00	0.00	0.00	0.00	0.00	0.00
01-00-41135	Water Sales-Ag/Dom Unbilled Me	0.00	0.00	0.00	0.00	0.00	0.00	0.00
01-00-41140	Water Sales-Ag. Met Cert.	0.00	0.00	0.00	0.00	0.00	0.00	0.00
01-00-41145	Water Sales-Ag. Unbill MET Cer	0.00	0.00	0.00	0.00	0.00	0.00	0.00
01-00-41160	Water Sales-Ag. Non Discount	0.00	2,942,008.75	2,942,008.75	-2,942,008.75	0.00	-2,942,008.75	0.00
01-00-41165	Water Sales-Ag.Nondis Unbilled	0.00	225,289.99	225,289.99	-225,289.99	0.00	-225,289.99	0.00
01-00-41170	Water Sales-Construction	0.00	134,405.60	134,405.60	-134,405.60	0.00	-134,405.60	0.00
01-00-41175	Water Sales-Construction-Unbil	0.00	-1,992.78	-1,992.78	1,992.78	0.00	1,992.78	0.00
01-00-41180	Water Sales Sawr Full Agric	0.00	3,558,298.62	3,558,298.62	-3,558,298.62	0.00	-3,558,298.62	0.00
01-00-41185	Water Sales-Sawr Ag Unbilled	0.00	69,138.36	69,138.36	-69,138.36	0.00	-69,138.36	0.00
01-00-41190	Water Sales-Sawr Ag/Dom	10,598,686.00	5,293,142.03	5,293,142.03	5,305,543.97	0.00	5,305,543.97	50.06
01-00-41195	Water Sales Sawr Ag/D Unbilled	0.00	88,866.64	88,866.64	-88,866.64	0.00	-88,866.64	0.00
01-00-42120	Monthly O & M Charges	5,283,629.27	4,512,769.18	4,512,769.18	770,860.09	0.00	770,860.09	14.59
01-00-42121	Infrastructure Access Charge	4,508,350.58	4,431,121.16	4,431,121.16	77,229.42	0.00	77,229.42	1.71
01-00-42130	Readiness-To-Serve Rev Id#1	486,481.00	274,772.25	274,772.25	211,708.75	0.00	211,708.75	43.52
01-00-42140	Pumping Charges	426,052.34	362,974.70	362,974.70	63,077.64	0.00	63,077.64	14.81
01-00-43101	Operating Inc Turn On/Off Fees	2,500.00	7,350.00	7,350.00	-4,850.00	0.00	-4,850.00	0.00
01-00-43104	Operating Inc. R.P. Charges	218,976.00	208,916.75	208,916.75	10,059.25	0.00	10,059.25	4.59
01-00-43106	Operating Inc Water Letter Fee	500.00	1,550.00	1,550.00	-1,050.00	0.00	-1,050.00	0.00
01-00-43109	Operating Inc Inspections	30,000.00	37,150.00	37,150.00	-7,150.00	0.00	-7,150.00	0.00
01-00-43110	Operating Inc Plans And Specs	3,000.00	650.00	650.00	2,350.00	0.00	2,350.00	78.33
01-00-43111	Operating Inc Install Fees,Hyd	2,400.00	3,970.00	3,970.00	-1,570.00	0.00	-1,570.00	0.00
01-00-43114	Operating Inc-Miscellaneous	48,600.00	8,734.96	8,734.96	39,865.04	0.00	39,865.04	82.03
01-00-43116	New Meter Sales/Install Parts	8,500.00	20,265.00	20,265.00	-11,765.00	0.00	-11,765.00	0.00
01-00-43117	Notice Delivery Revenue	0.00	35,728.00	35,728.00	-35,728.00	0.00	-35,728.00	0.00
	R10 Sub Totals:	35,143,344.19	28,590,461.88	28,590,461.88	6,552,882.31	0.00	6,552,882.31	18.65
R40	INTEREST EXPENSE							

General Ledger

Interim Financials

User: vmartinez
 Printed: 7/14/2016 - 1:59 PM
 Period: 1 to 11, 2016



Account Number	Description	Budget Amount	Period Amount	YTD Amount	YTD Var	Encumbered Amount	Available	% Available
01-00-49301	Property Tax Rev. - Ad Valorem	316,383.00	335,422.96	335,422.96	-19,039.96	0.00	-19,039.96	0.00
	R40 Sub Totals:	316,383.00	335,422.96	335,422.96	-19,039.96	0.00	-19,039.96	0.00
R50	INTEREST INCOME							
01-00-49201	Interest Revenues-Water Fund	4,342.28	0.00	0.00	4,342.28	0.00	4,342.28	100.00
	R50 Sub Totals:	4,342.28	0.00	0.00	4,342.28	0.00	4,342.28	100.00
R70	OTHER REVENUE							
01-00-49102	Non Oper Inc-Nsf Check Fees	0.00	1,650.00	1,650.00	-1,650.00	0.00	-1,650.00	0.00
01-00-49109	Non Oper Inc-Miscellaneous	60,360.00	19,276.29	19,276.29	41,083.71	0.00	41,083.71	68.06
	R70 Sub Totals:	60,360.00	20,926.29	20,926.29	39,433.71	0.00	39,433.71	65.33
R80	CURRENT YEAR NET REV/EXP							
01-00-39200	Current Year Net Rev/Exp	0.00	0.00	0.00	0.00	0.00	0.00	0.00
	R80 Sub Totals:	0.00	0.00	0.00	0.00	0.00	0.00	0.00
	Revenue Sub Totals:	35,524,429.47	28,946,811.13	28,946,811.13	6,577,618.34	0.00	6,577,618.34	18.52
E01	Cost of Water Sold							
01-00-50001	Water Purchases	17,962,086.93	17,352,927.56	17,352,927.56	609,159.37	0.00	609,159.37	3.39
01-00-50002	Ag Credit-Iawp	0.00	0.00	0.00	0.00	0.00	0.00	0.00
01-00-50003	Water In Storage	0.00	-124,283.30	-124,283.30	124,283.30	0.00	124,283.30	0.00
01-00-50005	Ready To Serve Charge	527,580.00	483,618.63	483,618.63	43,961.37	0.00	43,961.37	8.33
01-00-50006	Infrastructure Access Charge	435,546.00	399,158.00	399,158.00	36,388.00	0.00	36,388.00	8.35
01-00-50008	Ag Credit-Sawr	-1,605,654.82	-1,181,947.00	-1,181,947.00	-423,707.82	0.00	-423,707.82	0.00
01-00-50009	Seasonal Storage Credit	0.00	0.00	0.00	0.00	0.00	0.00	0.00
01-00-50010	Customer Service Charge	1,204,945.50	1,104,495.75	1,104,495.75	100,449.75	0.00	100,449.75	8.34
01-00-50011	Capacity Reservation Charge	622,440.00	567,629.52	567,629.52	54,810.48	0.00	54,810.48	8.81
01-00-50012	Emergency Storage Charge	2,148,367.50	1,635,616.65	1,635,616.65	512,750.85	0.00	512,750.85	23.87
01-00-50013	Supply Reliability Charge	0.00	308,239.60	308,239.60	-308,239.60	0.00	-308,239.60	0.00
01-00-52176	Overhead Transfer To Gen Fund	0.00	1,106,937.95	1,106,937.95	-1,106,937.95	0.00	-1,106,937.95	0.00
	E01 Sub Totals:	21,295,311.11	21,652,393.36	21,652,393.36	-357,082.25	0.00	-357,082.25	0.00
E05	PAYROLL & EMPLOYEE EXPENSES							
01-00-56101	Regular Salaries	0.00	0.00	0.00	0.00	0.00	0.00	0.00
01-00-56102	Temporary Extra Help	0.00	0.00	0.00	0.00	0.00	0.00	0.00
01-00-56205	Jpa Shared Labor	0.00	0.00	0.00	0.00	0.00	0.00	0.00
01-00-56500	Employee Retirement & Benefits	0.00	0.00	0.00	0.00	0.00	0.00	0.00
01-00-56501	Employer'S Share Fica Ssi	0.00	7,140.67	7,140.67	-7,140.67	0.00	-7,140.67	0.00
01-00-56502	Employer'S Share Fica Medicare	0.00	0.00	0.00	0.00	0.00	0.00	0.00
01-00-56503	Medical Ins Acwa Health Ben	0.00	565,618.38	565,618.38	-565,618.38	0.00	-565,618.38	0.00
01-00-56504	Dental Insurance	0.00	53,818.50	53,818.50	-53,818.50	0.00	-53,818.50	0.00

General Ledger

Interim Financials

User: vmartinez
 Printed: 7/14/2016 - 1:59 PM
 Period: 1 to 11, 2016



Account Number	Description	Budget Amount	Period Amount	YTD Amount	YTD Var	Encumbered Amount	Available	% Available
01-00-56505	Vision Ins Acwa Serv Corp	0.00	7,442.56	7,442.56	-7,442.56	0.00	-7,442.56	0.00
01-00-56506	Life, S/T, L/T Disability Ins	0.00	39,563.01	39,563.01	-39,563.01	0.00	-39,563.01	0.00
01-00-56507	Retirement - Calpers	0.00	0.00	0.00	0.00	0.00	0.00	0.00
01-00-56508	Employee Sick Leave	0.00	0.00	0.00	0.00	0.00	0.00	0.00
01-00-56511	Employee Uniform Allowance	0.00	0.00	0.00	0.00	0.00	0.00	0.00
01-00-56513	Employee Relations	0.00	0.00	0.00	0.00	0.00	0.00	0.00
01-00-56514	Employee Training Safety	0.00	0.00	0.00	0.00	0.00	0.00	0.00
01-00-56515	Worker'S Compensation Ins	0.00	0.00	0.00	0.00	0.00	0.00	0.00
01-00-56516	State Unemployment Ins, E.T.T.	0.00	677.12	677.12	-677.12	0.00	-677.12	0.00
01-00-56517	Employee Paid Time Off Exp	0.00	0.00	0.00	0.00	0.00	0.00	0.00
01-00-56520	Deferred Comp-Employer Contrib	0.00	78,410.00	78,410.00	-78,410.00	0.00	-78,410.00	0.00
01-00-56524	Other Post Employment Benefits	0.00	0.00	0.00	0.00	0.00	0.00	0.00
01-00-56530	GASB 68 Penion	0.00	0.00	0.00	0.00	0.00	0.00	0.00
01-00-57100	Depreciation Expenses-Curr Yr	0.00	1,061,255.00	1,061,255.00	-1,061,255.00	0.00	-1,061,255.00	0.00
01-00-57200	Bad Debt Expense	0.00	0.00	0.00	0.00	0.00	0.00	0.00
01-00-80010	Labor Applied To Cip-Water	0.00	0.00	0.00	0.00	0.00	0.00	0.00
01-00-80020	Overhead Applied To Cip-Water	0.00	0.00	0.00	0.00	0.00	0.00	0.00
01-00-80030	Equipment Applied To Jobs	0.00	0.00	0.00	0.00	0.00	0.00	0.00
01-00-81000	Buildings And Improvements	0.00	0.00	0.00	0.00	0.00	0.00	0.00
01-00-84000	Communication Equipment	0.00	0.00	0.00	0.00	0.00	0.00	0.00
01-00-85000	Telemetry	0.00	0.00	0.00	0.00	0.00	0.00	0.00
01-00-87000	Computer Hardwar And Software	0.00	0.00	0.00	0.00	0.00	0.00	0.00
01-00-88000	Pumps	0.00	0.00	0.00	0.00	0.00	0.00	0.00
	E05 Sub Totals:	0.00	1,813,925.24	1,813,925.24	-1,813,925.24	0.00	-1,813,925.24	0.00
	Expense Sub Totals:	21,295,311.11	23,466,318.60	23,466,318.60	-2,171,007.49	0.00	-2,171,007.49	0.00
	Dept 00 Sub Totals:	-14,229,118.36	-5,480,492.53	-5,480,492.53	-8,748,625.83	0.00		
Dept 01-20	BOARD							
E05	PAYROLL & EMPLOYEE EXPENSES							
01-20-56202	Board Member Expenses	0.00	1,350.00	1,350.00	-1,350.00	0.00	-1,350.00	0.00
	E05 Sub Totals:	0.00	1,350.00	1,350.00	-1,350.00	0.00	-1,350.00	0.00
E40	ADMINISTRATION & HR EXPENSES							
01-20-56501	FISCAR	0.00	83.70	83.70	-83.70	0.00	-83.70	0.00
01-20-56502	MEDIR	0.00	19.58	19.58	-19.58	0.00	-19.58	0.00
	E40 Sub Totals:	0.00	103.28	103.28	-103.28	0.00	-103.28	0.00
	Expense Sub Totals:	0.00	1,453.28	1,453.28	-1,453.28	0.00	-1,453.28	0.00

General Ledger

Interim Financials

User: vmartinez
 Printed: 7/14/2016 - 1:59 PM
 Period: 1 to 11, 2016



Account Number	Description	Budget Amount	Period Amount	YTD Amount	YTD Var	Encumbered Amount	Available	% Available
	Dept 20 Sub Totals:	0.00	1,453.28	1,453.28	-1,453.28	0.00		
Dept 01-31	PUMPING							
E05	PAYROLL & EMPLOYEE EXPENSES							
01-31-56101	Regular Salaries	85,495.51	62,038.75	62,038.75	23,456.76	0.00	23,456.76	27.44
01-31-56103	Overtime Paid, Comptime Earn.	500.00	150.03	150.03	349.97	0.00	349.97	69.99
01-31-56501	Employer'S Share Fica Ssi	5,300.72	3,735.29	3,735.29	1,565.43	0.00	1,565.43	29.53
01-31-56502	Employer'S Share Fica Medicare	1,239.68	716.02	716.02	523.66	0.00	523.66	42.24
01-31-56503	Medical Ins Acwa Health Ben	18,110.00	9,887.60	9,887.60	8,222.40	0.00	8,222.40	45.40
01-31-56504	Dental Insurance	956.38	292.74	292.74	663.64	0.00	663.64	69.39
01-31-56505	Vision Ins Acwa	223.00	276.34	276.34	-53.34	0.00	-53.34	0.00
01-31-56506	Life, S/T,L/T Disability Ins	670.72	172.29	172.29	498.43	0.00	498.43	74.31
01-31-56507	Retirement-Calpers	14,277.75	6,434.22	6,434.22	7,843.53	0.00	7,843.53	54.94
01-31-56509	Employee Holidays	0.00	0.00	0.00	0.00	0.00	0.00	0.00
01-31-56512	Employee Training/Tuition Reim	0.00	0.00	0.00	0.00	0.00	0.00	0.00
01-31-56515	Worker'S Compensation Ins	3,243.68	1,785.83	1,785.83	1,457.85	0.00	1,457.85	44.94
01-31-56516	State Unemployment Ins, E.T.T.	200.00	117.42	117.42	82.58	0.00	82.58	41.29
01-31-56520	Deferred Comp-Employer Contrib	2,600.00	229.06	229.06	2,370.94	0.00	2,370.94	91.19
01-31-56524	Other Post Employment Benefits	741.27	0.00	0.00	741.27	0.00	741.27	100.00
	E05 Sub Totals:	133,558.71	85,835.59	85,835.59	47,723.12	0.00	47,723.12	35.73
E10	PUMPING OPERATION EXPENSES							
01-31-56508	Employee Sick Leave	0.00	0.00	0.00	0.00	0.00	0.00	0.00
01-31-56510	EMPLOYEE VACATION	0.00	0.00	0.00	0.00	0.00	0.00	0.00
01-31-56517	EMPLOYEE PAID TIME OFF EXP	0.00	0.00	0.00	0.00	0.00	0.00	0.00
01-31-63100	Equipment Maintenance/Repair	61,500.00	45,673.82	45,673.82	15,826.18	0.00	15,826.18	25.73
01-31-63200	Equipment Rental	0.00	0.00	0.00	0.00	0.00	0.00	0.00
01-31-63401	Building Maintenance	1,500.00	2,349.78	2,349.78	-849.78	0.00	-849.78	0.00
01-31-63421	Fuel and Oil	0.00	0.00	0.00	0.00	0.00	0.00	0.00
01-31-72000	Supplies & Services	12,000.00	8,280.81	8,280.81	3,719.19	0.00	3,719.19	30.99
01-31-72150	Regulatory Permits	7,500.00	1,600.00	1,600.00	5,900.00	0.00	5,900.00	78.67
01-31-73000	Small Tools And Equipment	1,000.00	0.00	0.00	1,000.00	0.00	1,000.00	100.00
01-31-75300	Travel/Conferences/Training	0.00	0.00	0.00	0.00	0.00	0.00	0.00
01-31-78000	Utilities - Electricity	526,000.00	406,853.82	406,853.82	119,146.18	0.00	119,146.18	22.65
01-31-78500	Utilities - Natural Gas	0.00	0.00	0.00	0.00	0.00	0.00	0.00
01-31-82000	Shop And Field Equipment	0.00	0.00	0.00	0.00	0.00	0.00	0.00
	E10 Sub Totals:	609,500.00	464,758.23	464,758.23	144,741.77	0.00	144,741.77	23.75
	Expense Sub Totals:	743,058.71	550,593.82	550,593.82	192,464.89	0.00	192,464.89	25.90
Dept 01-32	Dept 31 Sub Totals:	743,058.71	550,593.82	550,593.82	192,464.89	0.00		
	OPERATIONS							

General Ledger

Interim Financials

User: vmartinez
 Printed: 7/14/2016 - 1:59 PM
 Period: 1 to 11, 2016



Account Number	Description	Budget Amount	Period Amount	YTD Amount	YTD Var	Encumbered Amount	Available	% Available
E05	PAYROLL & EMPLOYEE EXPENSES							
01-32-56101	Regular Salaries	625,640.76	539,820.31	539,820.31	85,820.45	0.00	85,820.45	13.72
01-32-56103	Overtime Paid, Comptime Earn.	45,000.00	49,761.57	49,761.57	-4,761.57	0.00	-4,761.57	0.00
01-32-56501	Employer'S Share Fica Ssi	38,789.73	34,988.55	34,988.55	3,801.18	0.00	3,801.18	9.80
01-32-56502	Employer'S Share Fica Medicare	9,071.79	8,820.48	8,820.48	251.31	0.00	251.31	2.77
01-32-56503	Medical Ins Acwa Health Ben	109,421.32	96,104.39	96,104.39	13,316.93	0.00	13,316.93	12.17
01-32-56504	Dental Insurance	8,911.14	2,938.09	2,938.09	5,973.05	0.00	5,973.05	67.03
01-32-56505	Vision Ins Acwa	2,338.84	2,531.50	2,531.50	-192.66	0.00	-192.66	0.00
01-32-56506	Life, S/T,L/T Disability Ins	6,136.36	1,503.55	1,503.55	4,632.81	0.00	4,632.81	75.50
01-32-56507	Retirement-Calpers	104,482.01	55,315.46	55,315.46	49,166.55	0.00	49,166.55	47.06
01-32-56509	Employee Holidays	0.00	732.96	732.96	-732.96	0.00	-732.96	0.00
01-32-56512	Employee Training/Tuition Reim	2,000.00	2,578.25	2,578.25	-578.25	0.00	-578.25	0.00
01-32-56515	Worker'S Compensation Ins	20,492.98	17,216.25	17,216.25	3,276.73	0.00	3,276.73	15.99
01-32-56516	State Unemployment Ins, E.T.T.	1,410.50	1,314.80	1,314.80	95.70	0.00	95.70	6.78
01-32-56517	Employee Paid Time Off Exp	0.00	10,494.33	10,494.33	-10,494.33	0.00	-10,494.33	0.00
01-32-56518	Duty Pay	10,400.00	12,535.63	12,535.63	-2,135.63	0.00	-2,135.63	0.00
01-32-56520	Deferred Comp-Employer Contrib	16,900.00	2,342.47	2,342.47	14,557.53	0.00	14,557.53	86.14
01-32-56524	Other Post Employment Benefits	5,424.48	0.00	0.00	5,424.48	0.00	5,424.48	100.00
	E05 Sub Totals:	1,006,419.91	838,998.59	838,998.59	167,421.32	0.00	167,421.32	16.64
E15	WATER OPERATION EXPENSES							
01-32-56508	Employee Sick Leave	0.00	0.00	0.00	0.00	0.00	0.00	0.00
01-32-56510	EMPLOYEE VACATION	0.00	0.00	0.00	0.00	0.00	0.00	0.00
01-32-60000	Electronics	39,900.00	4,699.14	4,699.14	35,200.86	0.00	35,200.86	88.22
01-32-63100	Equipment Maintenance/Repairs	20,500.00	16,528.50	16,528.50	3,971.50	0.00	3,971.50	19.37
01-32-63102	Equipment Maintenance Contract	52,800.00	13,681.55	13,681.55	39,118.45	0.00	39,118.45	74.09
01-32-63401	Building Maintenance	1,000.00	198.46	198.46	801.54	0.00	801.54	80.15
01-32-70000	Professional Services	0.00	0.00	0.00	0.00	0.00	0.00	0.00
01-32-72000	Supplies And Services	310,000.00	202,661.42	202,661.42	107,338.58	0.00	107,338.58	34.63
01-32-72010	Tank Maintenance	661,600.00	647,186.47	647,186.47	14,413.53	0.00	14,413.53	2.18
01-32-72150	Regulatory Permits	36,000.00	12,327.08	12,327.08	23,672.92	0.00	23,672.92	65.76
01-32-72200	Books And Resources	0.00	123.00	123.00	-123.00	0.00	-123.00	0.00
01-32-72400	Dues & Subscriptions	0.00	0.00	0.00	0.00	0.00	0.00	0.00
01-32-72700	Printing & Reproductions	5,000.00	0.00	0.00	5,000.00	0.00	5,000.00	100.00
01-32-72702	Public Notices/Advertising	0.00	0.00	0.00	0.00	0.00	0.00	0.00
01-32-73000	Small Tools And Equipment	1,000.00	242.79	242.79	757.21	0.00	757.21	75.72
01-32-75300	Travel/Conf/Training	1,500.00	2,377.04	2,377.04	-877.04	0.00	-877.04	0.00
01-32-78000	Utilities	11,900.00	13,175.51	13,175.51	-1,275.51	0.00	-1,275.51	0.00
01-32-82000	Capital Equipment	0.00	444.79	444.79	-444.79	0.00	-444.79	0.00
	E15 Sub Totals:	1,141,200.00	913,645.75	913,645.75	227,554.25	0.00	227,554.25	19.94
	Expense Sub Totals:	2,147,619.91	1,752,644.34	1,752,644.34	394,975.57	0.00	394,975.57	18.39

General Ledger

Interim Financials

User: vmartinez
 Printed: 7/14/2016 - 1:59 PM
 Period: 1 to 11, 2016



Account Number	Description	Budget Amount	Period Amount	YTD Amount	YTD Var	Encumbered Amount	Available	% Available
	Dept 32 Sub Totals:	2,147,619.91	1,752,644.34	1,752,644.34	394,975.57	0.00		
Dept 01-33	VALVE MAINTENANCE							
E05	PAYROLL & EMPLOYEE EXPENSES							
01-33-56101	Regular Salaries	300,525.41	289,000.54	289,000.54	11,524.87	0.00	11,524.87	3.83
01-33-56103	Overtime Paid, Comptime Earn.	4,500.00	7,013.46	7,013.46	-2,513.46	0.00	-2,513.46	0.00
01-33-56501	Employer'S Share Fica Ssi	18,632.58	17,769.90	17,769.90	862.68	0.00	862.68	4.63
01-33-56502	Employer'S Share Fica Medicare	4,357.62	4,467.62	4,467.62	-110.00	0.00	-110.00	0.00
01-33-56503	Medical Ins Acwa Health Ben	70,702.80	54,816.93	54,816.93	15,885.87	0.00	15,885.87	22.47
01-33-56504	Dental Insurance	4,526.41	1,588.51	1,588.51	2,937.90	0.00	2,937.90	64.91
01-33-56505	Vision Ins Acwa	890.88	1,431.45	1,431.45	-540.57	0.00	-540.57	0.00
01-33-56506	Life, S/T,L/T Disability Ins	3,160.06	806.94	806.94	2,353.12	0.00	2,353.12	74.46
01-33-56507	Retirement-Calpers	50,187.74	30,074.98	30,074.98	20,112.76	0.00	20,112.76	40.08
01-33-56509	Employee Holidays	0.00	704.61	704.61	-704.61	0.00	-704.61	0.00
01-33-56512	Employee Training/Tuition Reim	1,200.00	241.00	241.00	959.00	0.00	959.00	79.92
01-33-56515	Worker'S Compensation Ins	11,401.86	7,885.77	7,885.77	3,516.09	0.00	3,516.09	30.84
01-33-56516	State Unemployment Ins, E.T.T.	1,008.00	748.94	748.94	259.06	0.00	259.06	25.70
01-33-56517	Employee Paid Time Off Exp	0.00	5,419.87	5,419.87	-5,419.87	0.00	-5,419.87	0.00
01-33-56520	Deferred Comp-Employer Contrib	10,400.00	1,375.08	1,375.08	9,024.92	0.00	9,024.92	86.78
01-33-56524	Other Post Employment Benefits	2,605.64	0.00	0.00	2,605.64	0.00	2,605.64	100.00
	E05 Sub Totals:	484,099.00	423,345.60	423,345.60	60,753.40	0.00	60,753.40	12.55
E20	VALVE MAINTENANCE EXPENSES							
01-33-56508	Employee Sick Leave	0.00	0.00	0.00	0.00	0.00	0.00	0.00
01-33-56510	EMPLOYEE VACATION	0.00	0.00	0.00	0.00	0.00	0.00	0.00
01-33-63100	Equipment Maintenance	0.00	0.00	0.00	0.00	0.00	0.00	0.00
01-33-70000	Annual Audit Services	0.00	0.00	0.00	0.00	0.00	0.00	0.00
01-33-72000	Supplies And Services-Sewer	61,500.00	72,349.27	72,349.27	-10,849.27	0.00	-10,849.27	0.00
01-33-72200	Dues And Subscriptions	0.00	0.00	0.00	0.00	0.00	0.00	0.00
01-33-73000	Small Tools And Equipment	1,000.00	162.90	162.90	837.10	0.00	837.10	83.71
01-33-75300	Travel/Conferences/Training	1,000.00	0.00	0.00	1,000.00	0.00	1,000.00	100.00
01-33-82000	Shop And Field Equipment	50,000.00	75,172.88	75,172.88	-25,172.88	0.00	-25,172.88	0.00
	E20 Sub Totals:	113,500.00	147,685.05	147,685.05	-34,185.05	0.00	-34,185.05	0.00
E25	WATER DISTRIBUTION EXPENSES							
01-33-56514	Employee Training	0.00	195.00	195.00	-195.00	0.00	-195.00	0.00
	E25 Sub Totals:	0.00	195.00	195.00	-195.00	0.00	-195.00	0.00
	Expense Sub Totals:	597,599.00	571,225.65	571,225.65	26,373.35	0.00	26,373.35	4.41
	Dept 33 Sub Totals:	597,599.00	571,225.65	571,225.65	26,373.35	0.00		
Dept 01-34	WATER DISTRIBUTION							

General Ledger

Interim Financials

User: vmartinez
 Printed: 7/14/2016 - 1:59 PM
 Period: 1 to 11, 2016



Account Number	Description	Budget Amount	Period Amount	YTD Amount	YTD Var	Encumbered Amount	Available	% Available
	E25 Sub Totals:	361,184.00	366,490.80	366,490.80	-5,306.80	0.00	-5,306.80	0.00
	Expense Sub Totals:	1,832,526.41	1,520,699.96	1,520,699.96	311,826.45	0.00	311,826.45	17.02
	Dept 34 Sub Totals:	1,832,526.41	1,520,699.96	1,520,699.96	311,826.45	0.00		
Dept 01-35	METER SERVICES							
E05	PAYROLL & EMPLOYEE EXPENSES							
01-35-56101	Regular Salaries	436,907.36	423,947.54	423,947.54	12,959.82	0.00	12,959.82	2.97
01-35-56103	Overtime Paid, Comptime Earn.	3,000.00	16,357.63	16,357.63	-13,357.63	0.00	-13,357.63	0.00
01-35-56501	Employer'S Share Fica Ssi	27,088.26	25,478.61	25,478.61	1,609.65	0.00	1,609.65	5.94
01-35-56502	Employer'S Share Fica Medicare	6,335.16	6,468.87	6,468.87	-133.71	0.00	-133.71	0.00
01-35-56503	Medical Ins Acwa Health Ben	80,818.38	64,269.11	64,269.11	16,549.27	0.00	16,549.27	20.48
01-35-56504	Dental Insurance	5,308.23	1,690.84	1,690.84	3,617.39	0.00	3,617.39	68.15
01-35-56505	Vision Ins Acwa Serv Corp	1,057.92	2,254.32	2,254.32	-1,196.40	0.00	-1,196.40	0.00
01-35-56506	Life, S/T, L/T Disability Ins	3,691.95	893.40	893.40	2,798.55	0.00	2,798.55	75.80
01-35-56507	Retirement - Calpers	72,963.53	42,565.86	42,565.86	30,397.67	0.00	30,397.67	41.66
01-35-56509	Employee Holidays	0.00	761.92	761.92	-761.92	0.00	-761.92	0.00
01-35-56510	Employee Vacation	0.00	4,017.90	4,017.90	-4,017.90	0.00	-4,017.90	0.00
01-35-56512	Employee Training/Tuition Reim	2,000.00	1,024.14	1,024.14	975.86	0.00	975.86	48.79
01-35-56515	Worker'S Compensation Ins	19,069.91	10,313.70	10,313.70	8,756.21	0.00	8,756.21	45.92
01-35-56516	State Unemployment Ins, E.T.T.	1,485.75	1,175.92	1,175.92	309.83	0.00	309.83	20.85
01-35-56517	Employee Paid Time Off Exp	0.00	8,923.05	8,923.05	-8,923.05	0.00	-8,923.05	0.00
01-35-56520	Deferred Comp-Employer Contrib	14,950.00	1,318.34	1,318.34	13,631.66	0.00	13,631.66	91.18
	E05 Sub Totals:	674,676.45	611,461.15	611,461.15	63,215.30	0.00	63,215.30	9.37
E30	METER SERVICES EXPENSES							
01-35-56508	Employee Sick Leave	0.00	0.00	0.00	0.00	0.00	0.00	0.00
01-35-56524	OTHER POST EMPLOYMENT BENEF	3,788.11	0.00	0.00	3,788.11	0.00	3,788.11	100.00
01-35-63404	District Paid Insurance Claims	230,050.00	214,518.00	214,518.00	15,532.00	0.00	15,532.00	6.75
01-35-66000	Bad Debt Exp/Billing Adjust'S	0.00	0.00	0.00	0.00	0.00	0.00	0.00
01-35-66100	Professional Services	0.00	0.00	0.00	0.00	0.00	0.00	0.00
01-35-70000	Legal Services	0.00	0.00	0.00	0.00	0.00	0.00	0.00
01-35-72000	Supplies & Services	88,000.00	105,544.43	105,544.43	-17,544.43	0.00	-17,544.43	0.00
01-35-73000	Small Tools And Equipment	800.00	501.64	501.64	298.36	0.00	298.36	37.30
01-35-75300	Replacement Reserve-Oceanside	500.00	0.00	0.00	500.00	0.00	500.00	100.00
01-35-82000	Shop And Field Equipment	130,000.00	172,528.70	172,528.70	-42,528.70	0.00	-42,528.70	0.00
	E30 Sub Totals:	453,138.11	493,092.77	493,092.77	-39,954.66	0.00	-39,954.66	0.00
	Expense Sub Totals:	1,127,814.56	1,104,553.92	1,104,553.92	23,260.64	0.00	23,260.64	2.06

General Ledger

Interim Financials

User: vmartinez
 Printed: 7/14/2016 - 1:59 PM
 Period: 1 to 11, 2016



Account Number	Description	Budget Amount	Period Amount	YTD Amount	YTD Var	Encumbered Amount	Available	% Available
	Dept 35 Sub Totals:	1,127,814.56	1,104,553.92	1,104,553.92	23,260.64	0.00		
Dept 01-36	GARAGE							
E25	WATER DISTRIBUTION EXPENSES							
01-36-72000	Supplies And Services	0.00	-84.18	-84.18	84.18	0.00	84.18	0.00
	E25 Sub Totals:	0.00	-84.18	-84.18	84.18	0.00	84.18	0.00
	Expense Sub Totals:	0.00	-84.18	-84.18	84.18	0.00	84.18	0.00
	Dept 36 Sub Totals:	0.00	-84.18	-84.18	84.18	0.00		
Dept 01-41	ADMINISTRATION/HR							
E15	WATER OPERATION EXPENSES							
01-41-72000	Supplies And Services	0.00	0.00	0.00	0.00	0.00	0.00	0.00
	E15 Sub Totals:	0.00	0.00	0.00	0.00	0.00	0.00	0.00
E25	WATER DISTRIBUTION EXPENSES							
01-41-63401	Building Maint/Furnishing	0.00	555.65	555.65	-555.65	0.00	-555.65	0.00
	E25 Sub Totals:	0.00	555.65	555.65	-555.65	0.00	-555.65	0.00
	Expense Sub Totals:	0.00	555.65	555.65	-555.65	0.00	-555.65	0.00
	Dept 41 Sub Totals:	0.00	555.65	555.65	-555.65	0.00		
Dept 01-43	SAFETY							
E45	SAFTEY COMPLIANCE EXPENSES							
01-43-56513	EMPLOYEE RELATIONS	0.00	0.00	0.00	0.00	0.00	0.00	0.00
	E45 Sub Totals:	0.00	0.00	0.00	0.00	0.00	0.00	0.00
	Expense Sub Totals:	0.00	0.00	0.00	0.00	0.00	0.00	0.00
	Dept 43 Sub Totals:	0.00	0.00	0.00	0.00	0.00		
Dept 01-91	ENGINEERING							
E30	METER SERVICES EXPENSES							
01-91-82000	Shop And Field Equipment	0.00	12.85	12.85	-12.85	0.00	-12.85	0.00
	E30 Sub Totals:	0.00	12.85	12.85	-12.85	0.00	-12.85	0.00
	Expense Sub Totals:	0.00	12.85	12.85	-12.85	0.00	-12.85	0.00
	Dept 91 Sub Totals:	0.00	12.85	12.85	-12.85	0.00		

General Ledger

Interim Financials

User: vmartinez
 Printed: 7/14/2016 - 1:59 PM
 Period: 1 to 11, 2016



Account Number	Description	Budget Amount	Period Amount	YTD Amount	YTD Var	Encumbered Amount	Available	% Available
	Fund Revenue Sub Totals:	35,524,429.47	28,946,811.13	28,946,811.13	6,577,618.34	0.00	6,577,618.34	18.52
	Fund Expense Sub Totals:	27,743,929.70	28,967,973.89	28,967,973.89	-1,224,044.19	0.00	-1,224,044.19	0.00
	Fund 01 Sub Totals:	-7,780,499.77	21,162.76	21,162.76	-7,801,662.53	0.00		

General Ledger

Interim Financials

User: vmartinez
 Printed: 7/14/2016 - 1:59 PM
 Period: 1 to 11, 2016



Account Number	Description	Budget Amount	Period Amount	YTD Amount	YTD Var	Encumbered Amount	Available	% Available
Fund 02	SEWER FUND							
Dept 02-00								
R10	WATER REVENUE							
02-00-41210	Sewer Charges-Developing Accts	352,438.19	120,433.67	120,433.67	232,004.52	0.00	232,004.52	65.83
02-00-43101	Sewer-Oakcrest Service Charges	7,699.00	9,128.50	9,128.50	-1,429.50	0.00	-1,429.50	0.00
02-00-43106	Operating Inc-Sewer Letter Fee	0.00	950.00	950.00	-950.00	0.00	-950.00	0.00
02-00-43110	Operating Inc-Plan Chk/Ins Fee	0.00	17,836.00	17,836.00	-17,836.00	0.00	-17,836.00	0.00
	R10 Sub Totals:	360,137.19	148,348.17	148,348.17	211,789.02	0.00	211,789.02	58.81
R30	WASTEWATER REVENUE							
02-00-41110	Sewer Charges-Established Acct	2,441,447.88	2,267,246.50	2,267,246.50	174,201.38	0.00	174,201.38	7.14
02-00-49109	NON OPERATING REVENUE	0.00	0.00	0.00	0.00	0.00	0.00	0.00
	R30 Sub Totals:	2,441,447.88	2,267,246.50	2,267,246.50	174,201.38	0.00	174,201.38	7.14
R40	INTEREST EXPENSE							
02-00-49301	Property Tax Rev - Ad Valorem	41,263.00	47,367.85	47,367.85	-6,104.85	0.00	-6,104.85	0.00
	R40 Sub Totals:	41,263.00	47,367.85	47,367.85	-6,104.85	0.00	-6,104.85	0.00
R50	INTEREST INCOME							
02-00-49201	Interest Revenues-Sewer Fund	84,675.00	-404.09	-404.09	85,079.09	0.00	85,079.09	100.48
	R50 Sub Totals:	84,675.00	-404.09	-404.09	85,079.09	0.00	85,079.09	100.48
R80	CURRENT YEAR NET REV/EXP							
02-00-39200	Current Year Net Rev/Exp	0.00	0.00	0.00	0.00	0.00	0.00	0.00
	R80 Sub Totals:	0.00	0.00	0.00	0.00	0.00	0.00	0.00
	Revenue Sub Totals:	2,927,523.07	2,462,558.43	2,462,558.43	464,964.64	0.00	464,964.64	15.88
E05	PAYROLL & EMPLOYEE EXPENSES							
02-00-56517	Employee Paid Time Off Exp	0.00	0.00	0.00	0.00	0.00	0.00	0.00
	E05 Sub Totals:	0.00	0.00	0.00	0.00	0.00	0.00	0.00
E60	WASTEWATER EXPENSES							
02-00-52176	OVERHEAD TRANSFER TO GEN FUN	0.00	172,759.09	172,759.09	-172,759.09	0.00	-172,759.09	0.00
02-00-57100	DEPRECIATION EXPENSES-CURR YI	0.00	214,805.00	214,805.00	-214,805.00	0.00	-214,805.00	0.00
	E60 Sub Totals:	0.00	387,564.09	387,564.09	-387,564.09	0.00	-387,564.09	0.00
	Expense Sub Totals:	0.00	387,564.09	387,564.09	-387,564.09	0.00	-387,564.09	0.00
	Dept 00 Sub Totals:	-2,927,523.07	-2,074,994.34	-2,074,994.34	-852,528.73	0.00		
Dept 02-61	WASTEWATER							

General Ledger

Interim Financials

User: vmartinez
 Printed: 7/14/2016 - 1:59 PM
 Period: 1 to 11, 2016



Account Number	Description	Budget Amount	Period Amount	YTD Amount	YTD Var	Encumbered Amount	Available	% Available
E05	PAYROLL & EMPLOYEE EXPENSES							
02-61-56101	Regular Salaries	401,514.35	347,525.79	347,525.79	53,988.56	0.00	53,988.56	13.45
02-61-56103	Overtime Paid, Comp Time Earn.	60,000.00	22,456.38	22,456.38	37,543.62	0.00	37,543.62	62.57
02-61-56501	Employer'S Share Fica Ssi	24,893.89	22,129.62	22,129.62	2,764.27	0.00	2,764.27	11.10
02-61-56502	Employer'S Share Fica Medicare	5,821.96	5,571.36	5,571.36	250.60	0.00	250.60	4.30
02-61-56503	Medical Ins Acwa Health Ben	90,993.36	71,949.23	71,949.23	19,044.13	0.00	19,044.13	20.93
02-61-56504	Dental Insurance	8,230.00	1,745.21	1,745.21	6,484.79	0.00	6,484.79	78.79
02-61-56505	Vision Ins Acwa	1,113.60	1,901.76	1,901.76	-788.16	0.00	-788.16	0.00
02-61-56506	Life, S/T,L/T Disability Ins	4,686.35	848.60	848.60	3,837.75	0.00	3,837.75	81.89
02-61-56507	Retirement-Calpers	67,052.90	35,868.54	35,868.54	31,184.36	0.00	31,184.36	46.51
02-61-56509	Employee Holidays	0.00	906.39	906.39	-906.39	0.00	-906.39	0.00
02-61-56512	Employee Training/Tuition Reim	3,000.00	1,728.00	1,728.00	1,272.00	0.00	1,272.00	42.40
02-61-56515	Worker'S Compensation Ins	18,711.41	10,183.27	10,183.27	8,528.14	0.00	8,528.14	45.58
02-61-56516	State Unemployment Ins, E.T.T.	1,260.00	1,051.05	1,051.05	208.95	0.00	208.95	16.58
02-61-56517	Employee Paid Time Off Exp	0.00	7,149.17	7,149.17	-7,149.17	0.00	-7,149.17	0.00
02-61-56518	Duty Pay	10,400.00	11,500.00	11,500.00	-1,100.00	0.00	-1,100.00	0.00
02-61-56520	Deferred Comp-Employer Contrib	13,000.00	1,392.59	1,392.59	11,607.41	0.00	11,607.41	89.29
02-61-56524	Other Post Employment Benefits	3,481.24	0.00	0.00	3,481.24	0.00	3,481.24	100.00
	E05 Sub Totals:	714,159.06	543,906.96	543,906.96	170,252.10	0.00	170,252.10	23.84
E60	WASTEWATER EXPENSES							
02-61-56508	Employee Sick Leave	0.00	0.00	0.00	0.00	0.00	0.00	0.00
02-61-56510	EMPLOYEE VACATION	0.00	0.00	0.00	0.00	0.00	0.00	0.00
02-61-60000	Equipment	47,800.00	21,062.20	21,062.20	26,737.80	0.00	26,737.80	55.94
02-61-63100	Equipment Maintenance-Sewer	19,000.00	9,040.19	9,040.19	9,959.81	0.00	9,959.81	52.42
02-61-63200	Equipment Rental-Sewer	0.00	0.00	0.00	0.00	0.00	0.00	0.00
02-61-63300	Equipment Repair-Sewer	0.00	0.00	0.00	0.00	0.00	0.00	0.00
02-61-63401	Building Maintenance	500.00	0.00	0.00	500.00	0.00	500.00	100.00
02-61-63403	Other Facilities Maintenance	0.00	0.00	0.00	0.00	0.00	0.00	0.00
02-61-63421	Fuel And Oil	0.00	0.00	0.00	0.00	0.00	0.00	0.00
02-61-70000	Professional Services	0.00	0.00	0.00	0.00	0.00	0.00	0.00
02-61-70300	Legal Services	0.00	10,716.00	10,716.00	-10,716.00	0.00	-10,716.00	0.00
02-61-71000	Pump ,Ptrpr ,Aomtemamnce-Sewer	0.00	0.00	0.00	0.00	0.00	0.00	0.00
02-61-72000	Supplies And Services-Sewer	74,000.00	65,700.61	65,700.61	8,299.39	0.00	8,299.39	11.22
02-61-72150	Regulatory Permits	4,600.00	5,480.00	5,480.00	-880.00	0.00	-880.00	0.00
02-61-72200	Books And Resources	300.00	0.00	0.00	300.00	0.00	300.00	100.00
02-61-72400	Dues And Subscriptions	800.00	538.00	538.00	262.00	0.00	262.00	32.75
02-61-72600	Sewer Line Cleaning	33,000.00	8,576.66	8,576.66	24,423.34	0.00	24,423.34	74.01
02-61-72702	Public Notices Advertising	0.00	0.00	0.00	0.00	0.00	0.00	0.00
02-61-73000	Small Tools And Equipment	2,000.00	1,306.42	1,306.42	693.58	650.00	43.58	2.18
02-61-75300	Travel/Conferences/Training	2,000.00	500.00	500.00	1,500.00	0.00	1,500.00	75.00
02-61-77000	Sewage Treat.-Oceanside Plant	970,000.00	460,347.65	460,347.65	509,652.35	0.00	509,652.35	52.54
02-61-77100	Replacement Reserve-Oceanside	331,100.00	0.00	0.00	331,100.00	0.00	331,100.00	100.00

General Ledger

Interim Financials

User: vmartinez
 Printed: 7/14/2016 - 1:59 PM
 Period: 1 to 11, 2016



Account Number	Description	Budget Amount	Period Amount	YTD Amount	YTD Var	Encumbered Amount	Available	% Available
02-61-78000	Utilities	50,000.00	54,048.33	54,048.33	-4,048.33	0.00	-4,048.33	0.00
02-61-78300	Hazardous Waster Material Disp	12,000.00	8,670.00	8,670.00	3,330.00	0.00	3,330.00	27.75
02-61-78700	Utilities-Propane	2,000.00	4,967.23	4,967.23	-2,967.23	0.00	-2,967.23	0.00
02-61-82000	Shop And Field Equipment	20,000.00	21,095.64	21,095.64	-1,095.64	0.00	-1,095.64	0.00
02-61-83000	Vehicles	0.00	0.00	0.00	0.00	0.00	0.00	0.00
	E60 Sub Totals:	1,569,100.00	672,048.93	672,048.93	897,051.07	650.00	896,401.07	57.13
	Expense Sub Totals:	2,283,259.06	1,215,955.89	1,215,955.89	1,067,303.17	650.00	1,066,653.17	46.72
	Dept 61 Sub Totals:	2,283,259.06	1,215,955.89	1,215,955.89	1,067,303.17	650.00		
	Fund Revenue Sub Totals:	2,927,523.07	2,462,558.43	2,462,558.43	464,964.64	0.00	464,964.64	15.88
	Fund Expense Sub Totals:	2,283,259.06	1,603,519.98	1,603,519.98	679,739.08	650.00	679,089.08	29.74
	Fund 02 Sub Totals:	-644,264.01	-859,038.45	-859,038.45	214,774.44	650.00		

General Ledger

Interim Financials

User: vmartinez
 Printed: 7/14/2016 - 1:59 PM
 Period: 1 to 11, 2016



Account Number	Description	Budget Amount	Period Amount	YTD Amount	YTD Var	Encumbered Amount	Available	% Available
Fund 03	GENERAL FUND							
Dept 03-00								
R10	WATER REVENUE							
03-00-43102	Operating Inc Penalty/Int Chgs	185,000.00	194,432.58	194,432.58	-9,432.58	0.00	-9,432.58	0.00
03-00-43108	Operating Inc Plan Check Rev.	5,000.00	4,285.00	4,285.00	715.00	0.00	715.00	14.30
	R10 Sub Totals:	190,000.00	198,717.58	198,717.58	-8,717.58	0.00	-8,717.58	0.00
R50	INTEREST INCOME							
03-00-49201	Interest Revenues	0.00	1,437.74	1,437.74	-1,437.74	0.00	-1,437.74	0.00
	R50 Sub Totals:	0.00	1,437.74	1,437.74	-1,437.74	0.00	-1,437.74	0.00
R70	OTHER REVENUE							
03-00-42200	Overhead Trs From Water, Sewer	0.00	1,279,697.04	1,279,697.04	-1,279,697.04	0.00	-1,279,697.04	0.00
03-00-49108	Non Oper Inc-Rents And Leases	65,000.00	138,942.29	138,942.29	-73,942.29	0.00	-73,942.29	0.00
03-00-49109	Miscellaneous Revenue	8,500.00	51,495.49	51,495.49	-42,995.49	0.00	-42,995.49	0.00
03-00-49114	MISC Revenue - Eng. Services	0.00	2,409.50	2,409.50	-2,409.50	0.00	-2,409.50	0.00
	R70 Sub Totals:	73,500.00	1,472,544.32	1,472,544.32	-1,399,044.32	0.00	-1,399,044.32	0.00
R80	CURRENT YEAR NET REV/EXP							
03-00-39200	Current Year Net Rev/Exp	0.00	0.00	0.00	0.00	0.00	0.00	0.00
	R80 Sub Totals:	0.00	0.00	0.00	0.00	0.00	0.00	0.00
	Revenue Sub Totals:	263,500.00	1,672,699.64	1,672,699.64	-1,409,199.64	0.00	-1,409,199.64	0.00
E05	PAYROLL & EMPLOYEE EXPENSES							
03-00-56102	Temporary Extra Help	0.00	0.00	0.00	0.00	0.00	0.00	0.00
03-00-56517	Employee Paid Time Off Exp	0.00	0.00	0.00	0.00	0.00	0.00	0.00
	E05 Sub Totals:	0.00	0.00	0.00	0.00	0.00	0.00	0.00
	Expense Sub Totals:	0.00	0.00	0.00	0.00	0.00	0.00	0.00
	Dept 00 Sub Totals:	-263,500.00	-1,672,699.64	-1,672,699.64	1,409,199.64	0.00		
Dept 03-20	BOARD							
E05	PAYROLL & EMPLOYEE EXPENSES							
03-20-56202	Board Member Expenses	13,500.00	9,600.00	9,600.00	3,900.00	0.00	3,900.00	28.89
03-20-70000	Professional Services	0.00	0.00	0.00	0.00	0.00	0.00	0.00
03-20-72000	Supplies And Services	300.00	22.32	22.32	277.68	0.00	277.68	92.56
03-20-75300	Travel/Conferences/Training	7,495.00	1,914.44	1,914.44	5,580.56	0.00	5,580.56	74.46
	E05 Sub Totals:	21,295.00	11,536.76	11,536.76	9,758.24	0.00	9,758.24	45.82
E40	ADMINISTRATION & HR EXPENSES							

General Ledger

Interim Financials

User: vmartinez
 Printed: 7/14/2016 - 1:59 PM
 Period: 1 to 11, 2016



Account Number	Description	Budget Amount	Period Amount	YTD Amount	YTD Var	Encumbered Amount	Available	% Available
E75	BOARD OF DIRECTORS							
03-29-56202	Director's Compensation	0.00	0.00	0.00	0.00	0.00	0.00	0.00
03-29-75300	Travel/Conf/Training	0.00	100.00	100.00	-100.00	0.00	-100.00	0.00
	E75 Sub Totals:	0.00	100.00	100.00	-100.00	0.00	-100.00	0.00
	Expense Sub Totals:	0.00	100.00	100.00	-100.00	0.00	-100.00	0.00
	Dept 29 Sub Totals:	0.00	100.00	100.00	-100.00	0.00		
Dept 03-34	WATER DISTRIBUTION							
E05	PAYROLL & EMPLOYEE EXPENSES							
03-34-56103	Overtime Paid, Comp Time Earn.	0.00	0.00	0.00	0.00	0.00	0.00	0.00
	E05 Sub Totals:	0.00	0.00	0.00	0.00	0.00	0.00	0.00
	Expense Sub Totals:	0.00	0.00	0.00	0.00	0.00	0.00	0.00
	Dept 34 Sub Totals:	0.00	0.00	0.00	0.00	0.00		
Dept 03-36	GARAGE							
E05	PAYROLL & EMPLOYEE EXPENSES							
03-36-56101	Regular Salaries	87,631.73	75,839.92	75,839.92	11,791.81	0.00	11,791.81	13.46
03-36-56103	Overtime Paid, Comp Time Earn.	1,000.00	0.00	0.00	1,000.00	0.00	1,000.00	100.00
03-36-56501	Employer'S Share Fica Ssi	5,433.17	4,219.97	4,219.97	1,213.20	0.00	1,213.20	22.33
03-36-56502	Employer'S Share Fica Medicare	1,270.66	1,068.59	1,068.59	202.07	0.00	202.07	15.90
03-36-56503	Medical Ins Acwa Health Ben	18,552.72	14,135.48	14,135.48	4,417.24	0.00	4,417.24	23.81
03-36-56504	Dental Insurance	1,618.14	317.08	317.08	1,301.06	0.00	1,301.06	80.40
03-36-56505	Vision Ins Acwa	214.25	377.14	377.14	-162.89	0.00	-162.89	0.00
03-36-56506	Life, S/T,L/T Disability Ins	1,333.72	158.25	158.25	1,175.47	0.00	1,175.47	88.13
03-36-56507	Retirement-Calpers	14,634.50	7,388.45	7,388.45	7,246.05	0.00	7,246.05	49.51
03-36-56509	Employee Holidays	0.00	0.00	0.00	0.00	0.00	0.00	0.00
03-36-56512	Employee Training/Tuition Reim	500.00	0.00	0.00	500.00	0.00	500.00	100.00
03-36-56515	Worker'S Compensation Ins	1,906.69	2,046.69	2,046.69	-140.00	0.00	-140.00	0.00
03-36-56516	State Unemployment Ins, E.T.T.	242.58	205.82	205.82	36.76	0.00	36.76	15.15
03-36-56520	Deferred Comp-Employer Contrib	2,500.98	238.17	238.17	2,262.81	0.00	2,262.81	90.48
03-36-56524	Other Post Employment Benefits	759.79	0.00	0.00	759.79	0.00	759.79	100.00
	E05 Sub Totals:	137,598.93	105,995.56	105,995.56	31,603.37	0.00	31,603.37	22.97
E35	GARAGE EXPENSES							
03-36-56508	Employee Sick Leave	0.00	0.00	0.00	0.00	0.00	0.00	0.00
03-36-56510	EMPLOYEE VACATION	0.00	0.00	0.00	0.00	0.00	0.00	0.00
03-36-56517	EMPLOYEE PAID TIME OFF EXP	0.00	1,632.40	1,632.40	-1,632.40	0.00	-1,632.40	0.00
03-36-63000	Equipment	2,000.00	3,932.04	3,932.04	-1,932.04	0.00	-1,932.04	0.00
03-36-63100	Equipment Maintenance	20,000.00	71,007.68	71,007.68	-51,007.68	0.00	-51,007.68	0.00

General Ledger

Interim Financials

User: vmartinez
 Printed: 7/14/2016 - 1:59 PM
 Period: 1 to 11, 2016



Account Number	Description	Budget Amount	Period Amount	YTD Amount	YTD Var	Encumbered Amount	Available	% Available
03-36-63421	Fuel And Oil	144,375.00	66,186.37	66,186.37	78,188.63	0.00	78,188.63	54.16
03-36-63422	Repair, Supplies, Auto	70,000.00	51,195.64	51,195.64	18,804.36	0.00	18,804.36	26.86
03-36-72000	Supplies And Services	5,500.00	5,760.34	5,760.34	-260.34	0.00	-260.34	0.00
03-36-72100	Vendor Discounts Earned	0.00	0.00	0.00	0.00	0.00	0.00	0.00
03-36-72150	Regulatory Permits	2,700.00	1,541.00	1,541.00	1,159.00	0.00	1,159.00	42.93
03-36-72200	Books And Resources	0.00	0.00	0.00	0.00	0.00	0.00	0.00
03-36-73000	Small Tools And Equipment	1,000.00	1,291.33	1,291.33	-291.33	0.00	-291.33	0.00
03-36-75300	Travel/Conferences/Training	1,000.00	0.00	0.00	1,000.00	0.00	1,000.00	100.00
03-36-78300	Hazardous Waste	0.00	0.00	0.00	0.00	0.00	0.00	0.00
03-36-82000	Shop And Field Equipment	0.00	0.00	0.00	0.00	0.00	0.00	0.00
03-36-83000	Vehicles	215,000.00	209,289.23	209,289.23	5,710.77	0.00	5,710.77	2.66
	E35 Sub Totals:	461,575.00	411,836.03	411,836.03	49,738.97	0.00	49,738.97	10.78
	Expense Sub Totals:	599,173.93	517,831.59	517,831.59	81,342.34	0.00	81,342.34	13.58
	Dept 36 Sub Totals:	599,173.93	517,831.59	517,831.59	81,342.34	0.00		
Dept 03-41 E05	ADMINISTRATION/HR PAYROLL & EMPLOYEE EXPENSES							
03-41-56101	Regular Salaries	739,627.64	566,094.00	566,094.00	173,533.64	0.00	173,533.64	23.46
03-41-56103	Overtime Paid, Comp Time Earn.	3,100.00	7,063.41	7,063.41	-3,963.41	0.00	-3,963.41	0.00
03-41-56501	Employer'S Share Fica Ssi	45,856.91	24,458.17	24,458.17	21,398.74	0.00	21,398.74	46.66
03-41-56502	Employer'S Share Fica Medicare	10,724.60	7,915.32	7,915.32	2,809.28	0.00	2,809.28	26.19
03-41-56503	Medical Ins Acwa Health Ben	94,146.24	54,106.39	54,106.39	40,039.85	0.00	40,039.85	42.53
03-41-56504	Dental Insurance	13,657.41	1,821.65	1,821.65	11,835.76	0.00	11,835.76	86.66
03-41-56505	Vision Ins Acwa	1,808.30	1,262.40	1,262.40	545.90	0.00	545.90	30.19
03-41-56506	Life, S/T,L/T Disability Ins	11,256.80	1,078.09	1,078.09	10,178.71	0.00	10,178.71	90.42
03-41-56507	Retirement-Calpers	123,517.82	52,890.36	52,890.36	70,627.46	0.00	70,627.46	57.18
03-41-56509	Employee Holidays	0.00	134.63	134.63	-134.63	0.00	-134.63	0.00
03-41-56511	Employee Uniform Allowance	16,000.00	12,662.33	12,662.33	3,337.67	0.00	3,337.67	20.86
03-41-56512	Employee Training/Tuition Reim	950.00	375.00	375.00	575.00	0.00	575.00	60.53
03-41-56515	Worker'S Compensation Ins	16,092.78	13,293.43	13,293.43	2,799.35	0.00	2,799.35	17.40
03-41-56516	State Unemployment Ins, E.T.T.	2,047.39	1,436.81	1,436.81	610.58	0.00	610.58	29.82
03-41-56520	Deferred Comp-Employer Contrib	21,108.75	1,260.20	1,260.20	19,848.55	0.00	19,848.55	94.03
03-41-56524	Other Post Employment Benefits	6,412.78	0.00	0.00	6,412.78	0.00	6,412.78	100.00
	E05 Sub Totals:	1,106,307.42	745,852.19	745,852.19	360,455.23	0.00	360,455.23	32.58
E40	ADMINISTRATION & HR EXPENSES							
03-41-56102	TEMPORARY EXTRA HELP	0.00	31,903.32	31,903.32	-31,903.32	0.00	-31,903.32	0.00
03-41-56508	Employee Sick Leave	0.00	0.00	0.00	0.00	0.00	0.00	0.00
03-41-56510	EMPLOYEE VACATION	0.00	0.00	0.00	0.00	0.00	0.00	0.00
03-41-56513	Employee Relations	8,475.00	6,307.61	6,307.61	2,167.39	0.00	2,167.39	25.57
03-41-56517	EMPLOYEE PAID TIME OFF EXP	0.00	5,538.92	5,538.92	-5,538.92	0.00	-5,538.92	0.00

General Ledger

Interim Financials

User: vmartinez
 Printed: 7/14/2016 - 1:59 PM
 Period: 1 to 11, 2016



Account Number	Description	Budget Amount	Period Amount	YTD Amount	YTD Var	Encumbered Amount	Available	% Available
03-41-60100	Computers	275,160.00	206,585.47	206,585.47	68,574.53	0.00	68,574.53	24.92
03-41-63100	Equipment Maintenance	0.00	236.10	236.10	-236.10	0.00	-236.10	0.00
03-41-63102	Equipment Maintenance Contract	2,500.00	0.00	0.00	2,500.00	0.00	2,500.00	100.00
03-41-63200	Equipment Rental	35,800.00	37,291.42	37,291.42	-1,491.42	0.00	-1,491.42	0.00
03-41-63400	Kitchen Supplies	3,000.00	3,099.11	3,099.11	-99.11	0.00	-99.11	0.00
03-41-63401	Building Maintenance	78,680.00	108,116.68	108,116.68	-29,436.68	0.00	-29,436.68	0.00
03-41-63402	Landscape Maintenance	0.00	0.00	0.00	0.00	0.00	0.00	0.00
03-41-63403	Other Facilities Maintenance	0.00	0.00	0.00	0.00	0.00	0.00	0.00
03-41-65000	Property/Liability Insurance	186,000.00	252,676.57	252,676.57	-66,676.57	0.00	-66,676.57	0.00
03-41-65100	District Paid Insurance Claims	20,000.00	5,259.58	5,259.58	14,740.42	0.00	14,740.42	73.70
03-41-70000	Professional Services	160,000.00	202,411.75	202,411.75	-42,411.75	0.00	-42,411.75	0.00
03-41-70300	Legal Services	200,000.00	170,139.00	170,139.00	29,861.00	0.00	29,861.00	14.93
03-41-70400	Bank Service Charges	0.00	0.00	0.00	0.00	0.00	0.00	0.00
03-41-70500	Management Services	0.00	0.00	0.00	0.00	0.00	0.00	0.00
03-41-72000	Supplies And Services	27,050.00	31,840.11	31,840.11	-4,790.11	0.00	-4,790.11	0.00
03-41-72200	Books And Resources	250.00	46.32	46.32	203.68	0.00	203.68	81.47
03-41-72400	Dues And Subscriptions	54,255.00	53,122.60	53,122.60	1,132.40	0.00	1,132.40	2.09
03-41-72700	Printing And Reproductions	0.00	0.00	0.00	0.00	0.00	0.00	0.00
03-41-72702	Public Notices/Advertising	1,000.00	429.95	429.95	570.05	0.00	570.05	57.01
03-41-72900	Stationary & Office Supplies	15,000.00	27,920.08	27,920.08	-12,920.08	0.00	-12,920.08	0.00
03-41-73000	Small Tools & Equipment	0.00	0.00	0.00	0.00	0.00	0.00	0.00
03-41-74000	Communicatons & Phone Bills	7,500.00	11,253.29	11,253.29	-3,753.29	0.00	-3,753.29	0.00
03-41-74100	Phone Bill	27,476.00	42,108.93	42,108.93	-14,632.93	0.00	-14,632.93	0.00
03-41-74200	PHONE BILL-MOBILE	0.00	0.00	0.00	0.00	0.00	0.00	0.00
03-41-75300	Travel/Conferences/Training	23,150.00	21,567.10	21,567.10	1,582.90	0.00	1,582.90	6.84
03-41-78000	Utilities-Electricity	38,280.00	41,687.26	41,687.26	-3,407.26	0.00	-3,407.26	0.00
03-41-78700	Utilities -Propane	3,715.00	0.00	0.00	3,715.00	0.00	3,715.00	100.00
03-41-78900	Trash Pick-Up	5,640.00	5,736.44	5,736.44	-96.44	0.00	-96.44	0.00
	E40 Sub Totals:	1,172,931.00	1,265,277.61	1,265,277.61	-92,346.61	0.00	-92,346.61	0.00
	Expense Sub Totals:	2,279,238.42	2,011,129.80	2,011,129.80	268,108.62	0.00	268,108.62	11.76
	Dept 41 Sub Totals:	2,279,238.42	2,011,129.80	2,011,129.80	268,108.62	0.00		
Dept 03-43	SAFETY							
E05	PAYROLL & EMPLOYEE EXPENSES							
03-43-56101	Regular Salaries	71,927.03	59,363.94	59,363.94	12,563.09	0.00	12,563.09	17.47
03-43-56103	Overtime Paid, Comp Time Earn.	300.00	811.63	811.63	-511.63	0.00	-511.63	0.00
03-43-56501	Employer'S Share Fica Ssi	4,459.48	4,284.58	4,284.58	174.90	0.00	174.90	3.92
03-43-56502	Employer'S Share Fica Medicare	1,042.94	1,084.56	1,084.56	-41.62	0.00	-41.62	0.00
03-43-56503	Medical Ins Acwa Health Ben	8,449.56	11,929.69	11,929.69	-3,480.13	0.00	-3,480.13	0.00
03-43-56504	Dental Insurance	1,328.15	527.18	527.18	800.97	0.00	800.97	60.31
03-43-56505	Vision Ins Acwa	175.85	411.04	411.04	-235.19	0.00	-235.19	0.00

General Ledger

Interim Financials

User: vmartinez
 Printed: 7/14/2016 - 1:59 PM
 Period: 1 to 11, 2016



Account Number	Description	Budget Amount	Period Amount	YTD Amount	YTD Var	Encumbered Amount	Available	% Available
03-43-56506	Life, S/T,L/T Disability Ins	1,094.70	175.33	175.33	919.37	0.00	919.37	83.98
03-43-56507	Retirement-Calpers	12,011.81	8,078.11	8,078.11	3,933.70	0.00	3,933.70	32.75
03-43-56509	Employee Holidays	0.00	0.00	0.00	0.00	0.00	0.00	0.00
03-43-56512	Employee Training/Tuition Reim	350.00	135.00	135.00	215.00	0.00	215.00	61.43
03-43-56515	Worker'S Compensation Ins	1,564.98	1,785.83	1,785.83	-220.85	0.00	-220.85	0.00
03-43-56516	State Unemployment Ins, E.T.T.	199.10	210.01	210.01	-10.91	0.00	-10.91	0.00
03-43-56520	Deferred Comp-Employer Contrib	2,052.78	515.56	515.56	1,537.22	0.00	1,537.22	74.88
03-43-56524	Other Post Employment Benefits	623.63	0.00	0.00	623.63	0.00	623.63	100.00
	E05 Sub Totals:	105,580.01	89,312.46	89,312.46	16,267.55	0.00	16,267.55	15.41
E45	SAFTEY COMPLIANCE EXPENSES							
03-43-56508	Employee Sick Leave	0.00	0.00	0.00	0.00	0.00	0.00	0.00
03-43-56510	EMPLOYEE VACATION	0.00	4,545.89	4,545.89	-4,545.89	0.00	-4,545.89	0.00
03-43-56513	EMPLOYEE RELATIONS	0.00	346.07	346.07	-346.07	0.00	-346.07	0.00
03-43-56517	EMPLOYEE PAID TIME OFF EXP	0.00	5,904.43	5,904.43	-5,904.43	0.00	-5,904.43	0.00
03-43-63000	Equipment	0.00	0.00	0.00	0.00	0.00	0.00	0.00
03-43-63100	Equipment Maintenance	8,000.00	5,590.49	5,590.49	2,409.51	0.00	2,409.51	30.12
03-43-63102	Equipment Maintenance Contract	14,700.00	13,314.77	13,314.77	1,385.23	0.00	1,385.23	9.42
03-43-63200	Equipment Rental	0.00	0.00	0.00	0.00	0.00	0.00	0.00
03-43-63401	Building Maintenance	0.00	0.00	0.00	0.00	0.00	0.00	0.00
03-43-70000	Professional Services	0.00	0.00	0.00	0.00	0.00	0.00	0.00
03-43-72000	Supplies And Services	27,500.00	6,348.05	6,348.05	21,151.95	0.00	21,151.95	76.92
03-43-72200	Books And Resources	200.00	0.00	0.00	200.00	0.00	200.00	100.00
03-43-72400	Dues And Subscriptions	800.00	754.00	754.00	46.00	0.00	46.00	5.75
03-43-72500	Safety Supplies	37,500.00	17,808.27	17,808.27	19,691.73	0.00	19,691.73	52.51
03-43-73000	Small Tools And Equipment	300.00	0.00	0.00	300.00	0.00	300.00	100.00
03-43-75300	Travel/Conferences/Training	3,000.00	483.20	483.20	2,516.80	0.00	2,516.80	83.89
	E45 Sub Totals:	92,000.00	55,095.17	55,095.17	36,904.83	0.00	36,904.83	40.11
E55	CUSTOMER SERVICE EXPENSES							
03-43-63422	Repair, Supplies, Auto	0.00	0.00	0.00	0.00	0.00	0.00	0.00
	E55 Sub Totals:	0.00	0.00	0.00	0.00	0.00	0.00	0.00
	Expense Sub Totals:	197,580.01	144,407.63	144,407.63	53,172.38	0.00	53,172.38	26.91
	Dept 43 Sub Totals:	197,580.01	144,407.63	144,407.63	53,172.38	0.00		
Dept 03-51	FINANCE							
E05	PAYROLL & EMPLOYEE EXPENSES							
03-51-56101	Regular Salaries	365,416.15	339,684.61	339,684.61	25,731.54	0.00	25,731.54	7.04
03-51-56103	Overtime Paid, Comp Time Earn.	200.00	2,459.00	2,459.00	-2,259.00	0.00	-2,259.00	0.00
03-51-56501	Employer'S Share Fica Ssi	22,655.80	20,726.93	20,726.93	1,928.87	0.00	1,928.87	8.51
03-51-56502	Employer'S Share Fica Medicare	5,298.53	5,173.89	5,173.89	124.64	0.00	124.64	2.35

General Ledger

Interim Financials

User: vmartinez
 Printed: 7/14/2016 - 1:59 PM
 Period: 1 to 11, 2016



Account Number	Description	Budget Amount	Period Amount	YTD Amount	YTD Var	Encumbered Amount	Available	% Available
03-51-56503	Medical Ins Acwa Health Ben	32,890.32	33,389.81	33,389.81	-499.49	0.00	-499.49	0.00
03-51-56504	Dental Insurance	3,287.00	1,334.98	1,334.98	1,952.02	0.00	1,952.02	59.39
03-51-56505	Vision Ins Acwa	890.88	1,046.36	1,046.36	-155.48	0.00	-155.48	0.00
03-51-56506	Life, S/T,L/T Disability Ins	2,072.50	676.14	676.14	1,396.36	0.00	1,396.36	67.38
03-51-56507	Retirement-Calpers	61,024.50	28,142.36	28,142.36	32,882.14	0.00	32,882.14	53.88
03-51-56509	Employee Holidays	0.00	758.61	758.61	-758.61	0.00	-758.61	0.00
03-51-56512	Employee Training/Tuition Reim	2,400.00	80.00	80.00	2,320.00	0.00	2,320.00	96.67
03-51-56515	Worker'S Compensation Ins	13,986.49	7,263.73	7,263.73	6,722.76	0.00	6,722.76	48.07
03-51-56516	State Unemployment Ins, E.T.T.	1,008.00	1,116.06	1,116.06	-108.06	0.00	-108.06	0.00
03-51-56520	Deferred Comp-Employer Contrib	10,400.00	1,106.79	1,106.79	9,293.21	0.00	9,293.21	89.36
03-51-56524	Other Post Employment Benefits	3,168.26	0.00	0.00	3,168.26	0.00	3,168.26	100.00
	E05 Sub Totals:	524,698.43	442,959.27	442,959.27	81,739.16	0.00	81,739.16	15.58
E50	FINANCE EXPENSES							
03-51-56508	Employee Sick Leave	0.00	0.00	0.00	0.00	0.00	0.00	0.00
03-51-56510	EMPLOYEE VACATION	0.00	0.00	0.00	0.00	0.00	0.00	0.00
03-51-56517	EMPLOYEE PAID TIME OFF EXP	0.00	2,652.73	2,652.73	-2,652.73	0.00	-2,652.73	0.00
03-51-63102	Equipment Maintenance Contract	0.00	0.00	0.00	0.00	0.00	0.00	0.00
03-51-69000	Postage	43,500.00	38,647.32	38,647.32	4,852.68	0.00	4,852.68	11.16
03-51-70000	Professional Services	0.00	0.00	0.00	0.00	0.00	0.00	0.00
03-51-70100	Annual Audit Services	14,420.00	18,270.00	18,270.00	-3,850.00	0.00	-3,850.00	0.00
03-51-70400	Bank Service Charges	50,000.00	44,595.44	44,595.44	5,404.56	0.00	5,404.56	10.81
03-51-72000	Supplies And Services	100.00	7,133.00	7,133.00	-7,033.00	0.00	-7,033.00	0.00
03-51-72200	Books And Resources	0.00	0.00	0.00	0.00	0.00	0.00	0.00
03-51-72400	DUES AND SUBSCRIPTIONS	0.00	0.00	0.00	0.00	0.00	0.00	0.00
03-51-72700	Printing And Reproductions	1,800.00	1,110.45	1,110.45	689.55	0.00	689.55	38.31
03-51-75300	Travel/Conferences/Training	2,500.00	1,935.52	1,935.52	564.48	0.00	564.48	22.58
	E50 Sub Totals:	112,320.00	114,344.46	114,344.46	-2,024.46	0.00	-2,024.46	0.00
	Expense Sub Totals:	637,018.43	557,303.73	557,303.73	79,714.70	0.00	79,714.70	12.51
	Dept 51 Sub Totals:	637,018.43	557,303.73	557,303.73	79,714.70	0.00		
Dept 03-52	CUSTOMER SERVICE							
E05	PAYROLL & EMPLOYEE EXPENSES							
03-52-56101	Regular Salaries	194,113.78	117,849.54	117,849.54	76,264.24	0.00	76,264.24	39.29
03-52-56103	Overtime Paid, Comp Time Earn.	3,500.00	3,093.62	3,093.62	406.38	0.00	406.38	11.61
03-52-56501	Employer'S Share Fica Ssi	12,035.05	7,900.72	7,900.72	4,134.33	0.00	4,134.33	34.35
03-52-56502	Employer'S Share Fica Medicare	2,814.65	1,873.39	1,873.39	941.26	0.00	941.26	33.44
03-52-56503	Medical Ins Acwa Health Ben	34,101.36	24,273.54	24,273.54	9,827.82	0.00	9,827.82	28.82
03-52-56504	Dental Insurance	3,584.36	529.58	529.58	3,054.78	0.00	3,054.78	85.23
03-52-56505	Vision Ins Acwa	474.58	423.41	423.41	51.17	0.00	51.17	10.78
03-52-56506	Life, S/T,L/T Disability Ins	2,954.33	165.47	165.47	2,788.86	0.00	2,788.86	94.40

General Ledger

Interim Financials

User: vmartinez
 Printed: 7/14/2016 - 1:59 PM
 Period: 1 to 11, 2016



Account Number	Description	Budget Amount	Period Amount	YTD Amount	YTD Var	Encumbered Amount	Available	% Available
03-52-56507	Retirement-Calpers	32,417.00	11,138.80	11,138.80	21,278.20	0.00	21,278.20	65.64
03-52-56509	Employee Holidays	0.00	208.28	208.28	-208.28	0.00	-208.28	0.00
03-52-56512	Employee Training/Tuition Reim	1,000.00	0.00	0.00	1,000.00	0.00	1,000.00	100.00
03-52-56515	Worker'S Compensation Ins	4,223.52	2,046.69	2,046.69	2,176.83	0.00	2,176.83	51.54
03-52-56516	State Unemployment Ins, E.T.T.	537.33	1,056.61	1,056.61	-519.28	0.00	-519.28	0.00
03-52-56520	Deferred Comp-Employer Contrib	5,539.95	498.06	498.06	5,041.89	0.00	5,041.89	91.01
03-52-56524	Other Post Employment Benefits	1,683.02	0.00	0.00	1,683.02	0.00	1,683.02	100.00
	E05 Sub Totals:	298,978.93	171,057.71	171,057.71	127,921.22	0.00	127,921.22	42.79
E55	CUSTOMER SERVICE EXPENSES							
03-52-56508	Employee Sick Leave	0.00	0.00	0.00	0.00	0.00	0.00	0.00
03-52-56510	EMPLOYEE VACATION	0.00	0.00	0.00	0.00	0.00	0.00	0.00
03-52-56517	EMPLOYEE PAID TIME OFF EXP	0.00	2,327.14	2,327.14	-2,327.14	0.00	-2,327.14	0.00
03-52-63100	Equipment Maintenance	300.00	0.00	0.00	300.00	0.00	300.00	100.00
03-52-63102	Equipment Maintenance Contract	0.00	0.00	0.00	0.00	0.00	0.00	0.00
03-52-63200	Equipment Rental	0.00	0.00	0.00	0.00	0.00	0.00	0.00
03-52-69100	Postal Services	0.00	0.00	0.00	0.00	0.00	0.00	0.00
03-52-69110	Bad Debt Exp/Billing Adjust'S	12,000.00	4,038.01	4,038.01	7,961.99	0.00	7,961.99	66.35
03-52-70000	Professional Services	0.00	0.00	0.00	0.00	0.00	0.00	0.00
03-52-72000	Supplies And Services	110,500.00	126,581.06	126,581.06	-16,081.06	0.00	-16,081.06	0.00
03-52-72700	Printing And Reproductions	2,200.00	2,794.12	2,794.12	-594.12	0.00	-594.12	0.00
03-52-75300	Travel/Conferences/Training	1,000.00	0.00	0.00	1,000.00	0.00	1,000.00	100.00
	E55 Sub Totals:	126,000.00	135,740.33	135,740.33	-9,740.33	0.00	-9,740.33	0.00
	Expense Sub Totals:	424,978.93	306,798.04	306,798.04	118,180.89	0.00	118,180.89	27.81
	Dept 52 Sub Totals:	424,978.93	306,798.04	306,798.04	118,180.89	0.00		
Dept 03-91	ENGINEERING							
E05	PAYROLL & EMPLOYEE EXPENSES							
03-91-56101	Regular Salaries	465,967.61	328,311.17	328,311.17	137,656.44	0.00	137,656.44	29.54
03-91-56103	Overtime Paid, Comp Time Earn.	4,000.00	2,131.57	2,131.57	1,868.43	0.00	1,868.43	46.71
03-91-56501	Employer'S Share Fica Ssi	28,889.99	18,090.00	18,090.00	10,799.99	0.00	10,799.99	37.38
03-91-56502	Employer'S Share Fica Medicare	6,756.53	4,588.23	4,588.23	2,168.30	0.00	2,168.30	32.09
03-91-56503	Medical Ins Acwa Health Ben	84,591.18	49,443.28	49,443.28	35,147.90	0.00	35,147.90	41.55
03-91-56504	Dental Insurance	8,604.21	1,442.69	1,442.69	7,161.52	0.00	7,161.52	83.23
03-91-56505	Vision Ins Acwa	1,139.23	1,241.94	1,241.94	-102.71	0.00	-102.71	0.00
03-91-56506	Life, S/T,L/T Disability Ins	7,091.82	599.42	599.42	6,492.40	0.00	6,492.40	91.55
03-91-56507	Retirement-Calpers	77,816.59	32,272.77	32,272.77	45,543.82	0.00	45,543.82	58.53
03-91-56509	Employee Holidays	0.00	287.11	287.11	-287.11	0.00	-287.11	0.00
03-91-56512	Employee Training/Tuition Reim	1,200.00	0.00	0.00	1,200.00	0.00	1,200.00	100.00
03-91-56515	Worker'S Compensation Ins	10,138.50	6,079.87	6,079.87	4,058.63	0.00	4,058.63	40.03
03-91-56516	State Unemployment Ins, E.T.T.	1,289.86	1,106.07	1,106.07	183.79	0.00	183.79	14.25

General Ledger

Interim Financials

User: vmartinez
 Printed: 7/14/2016 - 1:59 PM
 Period: 1 to 11, 2016



Account Number	Description	Budget Amount	Period Amount	YTD Amount	YTD Var	Encumbered Amount	Available	% Available
03-91-56520	Deferred Comp-Employer Contrib	13,298.57	1,325.36	1,325.36	11,973.21	0.00	11,973.21	90.03
03-91-56524	Other Post Employment Benefits	4,040.07	0.00	0.00	4,040.07	0.00	4,040.07	100.00
	E05 Sub Totals:	714,824.16	446,919.48	446,919.48	267,904.68	0.00	267,904.68	37.48
E65	ENGINEERING EXPENSES							
03-91-56102	TEMPORARY EXTRA HELP	0.00	0.00	0.00	0.00	0.00	0.00	0.00
03-91-56508	Employee Sick Leave	0.00	0.00	0.00	0.00	0.00	0.00	0.00
03-91-56510	EMPLOYEE VACATION	0.00	0.00	0.00	0.00	0.00	0.00	0.00
03-91-56517	EMPLOYEE PAID TIME OFF EXP	0.00	5,228.46	5,228.46	-5,228.46	0.00	-5,228.46	0.00
03-91-63000	Equipment	5,000.00	0.00	0.00	5,000.00	0.00	5,000.00	100.00
03-91-63100	Equipment Maintenance	0.00	0.00	0.00	0.00	0.00	0.00	0.00
03-91-63102	Equipment Maintenance Contract	62,310.00	53,500.00	53,500.00	8,810.00	0.00	8,810.00	14.14
03-91-63401	BUILDING MAINTENANCE	0.00	0.00	0.00	0.00	0.00	0.00	0.00
03-91-70000	Professional Services	200,000.00	176,687.44	176,687.44	23,312.56	0.00	23,312.56	11.66
03-91-72000	Supplies And Services	21,134.00	264,958.59	264,958.59	-243,824.59	0.00	-243,824.59	0.00
03-91-72150	Regulatory Permits	0.00	16,372.00	16,372.00	-16,372.00	0.00	-16,372.00	0.00
03-91-72200	Books And Resources	500.00	0.00	0.00	500.00	0.00	500.00	100.00
03-91-72400	Dues And Subscriptions	765.00	49.95	49.95	715.05	0.00	715.05	93.47
03-91-72700	Printing And Reproductions	0.00	32.00	32.00	-32.00	0.00	-32.00	0.00
03-91-72702	Public Notices/Advertising	0.00	0.00	0.00	0.00	0.00	0.00	0.00
03-91-73000	Small Tools & Equipment	0.00	0.00	0.00	0.00	0.00	0.00	0.00
03-91-75300	Travel/Conferences/Training	5,000.00	882.21	882.21	4,117.79	0.00	4,117.79	82.36
	E65 Sub Totals:	294,709.00	517,710.65	517,710.65	-223,001.65	0.00	-223,001.65	0.00
	Expense Sub Totals:	1,009,533.16	964,630.13	964,630.13	44,903.03	0.00	44,903.03	4.45
	Dept 91 Sub Totals:	1,009,533.16	964,630.13	964,630.13	44,903.03	0.00		
	Fund Revenue Sub Totals:	263,500.00	1,672,699.64	1,672,699.64	-1,409,199.64	0.00	-1,409,199.64	0.00
	Fund Expense Sub Totals:	5,168,897.53	4,514,862.72	4,514,862.72	654,034.81	0.00	654,034.81	12.65
	Fund 03 Sub Totals:	4,905,397.53	2,842,163.08	2,842,163.08	2,063,234.45	0.00		

General Ledger

Interim Financials

User: vmartinez
 Printed: 7/14/2016 - 1:59 PM
 Period: 1 to 11, 2016



Account Number	Description	Budget Amount	Period Amount	YTD Amount	YTD Var	Encumbered Amount	Available	% Available
	Revenue Totals:	38,715,452.54	33,082,069.20	33,082,069.20	5,633,383.34	0.00	5,633,383.34	14.55
	Expense Totals:	35,196,086.29	35,086,356.59	35,086,356.59	109,729.70	650.00	109,079.70	0.31
	Report Totals:	-3,519,366.25	2,004,287.39	2,004,287.39	-5,523,653.64	650.00		

AMERICAN EXPRESS BREAKDOWN
JUNE, 2016

NEW ACCOUNT

DATE OF CHARGE	AMOUNT	VENDOR & PURPOSE	GL#
06/03/16	\$ 252.50	CORELOGIC - REALQUEST MAP SEARCH, MORTGAGE DATA AND PROPERTY DETAIL DATA - May	03-91-72000
06/15/16	\$ 75.83	VILLAGE PIZZA - BIRTHDAY LUNCH	03-41-72000
06/16/16	\$ 6.21	VILLAGE PIZZA - BIRTHDAY LUNCH	03-41-72000
06/16/16	\$ 495.30	BULK OFFICE SUPPLY- HR FOLDERS	03-41-72900
06/17/16	\$ 75.00	CULLIGAN - WATER SOFTNER	03-41-63401
06/17/16	\$ 3,263.22	BRADY SAND - CLASS II BASE	01-34-72000
06/18/16	\$ 2,000.00	PALA MESA RESORT - EMPLOYEE RECOGNIZATON BANQUET DEPOSIT	03-41-56513
06/18/16	\$ 935.41	OFFICE DEPOT - BUSINESS CARDS, TONER, TSAWR POSTCARDS	03-41-72900
06/18/16	\$ 8,389.44	NATIONAL METER- METER SUPPLIES	01-35-72000
06/18/16	\$ 1,995.36	ABCANA INDUSTRIES - HYPOCHLORITE	01-32-72000
06/18/16	\$ 7,481.25	PROCOPIO, CORY, HARGREAVES & SAVITCH LLP - LEGAL SERVICES	03-41-70300
06/18/16	\$ 399.00	PROCOPIO, CORY, HARGREAVES & SAVITCH LLP - WATER	J2014200/03-91-72000
06/18/16	\$ 142.50	PROCOPIO, CORY, HARGREAVES & SAVITCH LLP - WATER	J201446/03-91-72000
06/18/16	\$ 470.25	PROCOPIO, CORY, HARGREAVES & SAVITCH LLP - WATER	J201661/03-91-56101
06/18/16	\$ 498.75	PROCOPIO, CORY, HARGREAVES & SAVITCH LLP - WATER	J201040/52-00-11158
06/18/16	\$ 114.00	PROCOPIO, CORY, HARGREAVES & SAVITCH LLP - WATER	J200720/03-91-72000
06/20/16	\$ 274.07	PACIFIC PIPELINE - HOSE REDUCER, FREIGHT CHARGE PASS THROUGH	01-00-14610
06/20/16	\$ 267.30	PACIFIC PIPELINE - METER FLANGE	01-00-14610
06/20/16	\$ 8,251.31	PACIFIC PIPELINE - VALVE R/W GATE FLG	01-00-14610
06/20/16	\$ 653.48	PRUDENTIAL OVERALL - MONTHLY UNIFORMS	03-41-56511
06/20/16	\$ 275.16	PRUDENTIAL OVERALL - MATS & MISC	03-41-63401
06/20/06	\$ 210.00	ATLAS PUMPING - MONTHLY BIN RENTAL	02-61-78300
06/21/16	\$ 199.00	FRED PRYOR SEMINARS	03-51-753000
06/21/16	\$ 199.00	FRED PRYOR SEMINARS	01-34-753000
06/21/16	\$ 199.00	FRED PRYOR SEMINARS	01-32-753000
06/24/16	\$ 80.00	JPIA ANNUAL TRAINING	03-41-56512
06/24/16	\$ 80.00	JPIA ANNUAL TRAINING	03-41-75300
06/22/16	\$ 148.43	AMAZON	01-32-72000
06/22/16	\$ 57.50	AMAZON	01-32-72000
06/22/16	\$ 27.01	AMAZON	01-32-72000
06/22/16	\$ 1,637.04	AMAZON	01-32-72000
06/22/16	\$ 20.05	AMAZON	01-32-72000
06/20/16	\$ 378.40	W.W. GRAINGER - FAN, FAN FILT GUARD, LOUVER PLATE KIT	01-32-60000
06/20/16	\$ 272.81	W.W. GRAINGER -DEPRESSED CTR WHL, BARRICADE TAPE, TWIST WHEEL	01-34-72000
CHECK #			
AMOUNT	\$ 39,823.58		

FY 2015-2016

Disbursement Date	Description	Bob Lucy-21	Jack Griffiths-22	Dennis Sanford-25	Helene Brazier-27	Tory Walker-29	Richard Bigley	William Stewart	Paul Christensen
07/31/15	CAL PERS - HEALTH INS. ASSURANT - DENTAL INS. CSDA,SAN DIEGO CHAPTER WATER AGENCIES ASSOC OF S.D. COUNCIL OF WATER UTILITIES DIRECTORS' MEETINGS MILEAGE EXPENSE REIMBURSEMENT FROM DIRECTORS	\$ 300.00	\$ 300.00	\$ 300.00	\$ 300.00	\$ 300.00	\$ 25.00		\$ 340.62
	Monthly Totals	\$ 300.00	\$ 300.00	\$ 300.00	\$ 300.00	\$ 325.00			\$ -
08/31/15	CAL PERS - HEALTH INS. ASSURANT - DENTAL INS. CSDA,SAN DIEGO CHAPTER WATER AGENCIES ASSOC OF S.D. COUNCIL OF WATER UTILITIES DIRECTORS' MEETINGS MILEAGE EXPENSE REIMBURSEMENT FROM DIRECTORS			\$ 456.20					\$ 340.56
	Monthly Totals	\$ -	\$ -	\$ 456.20	\$ -	\$ -			\$ -
09/30/15	CAL PERS - HEALTH INS. ASSURANT - DENTAL INS. CSDA,SAN DIEGO CHAPTER WATER AGENCIES ASSOC OF S.D. COUNCIL OF WATER UTILITIES DIRECTORS' MEETINGS MILEAGE AND EXPENSES REIMBURSEMENT FROM DIRECTORS	\$ 300.00	\$ 300.00	\$ 450.00	\$ 300.00	\$ 450.00	\$ 25.00		\$ 340.56
	Monthly Totals	\$ 300.00	\$ 329.34	\$ 450.00	\$ 300.00	\$ 475.00			\$ -
10/31/15	CAL PERS - HEALTH INS. ASSURANT - DENTAL INS. CSDA,SAN DIEGO CHAPTER WATER AGENCIES ASSOC OF S.D. COUNCIL OF WATER UTILITIES DIRECTORS' MEETINGS MILEAGE AND EXPENSES REIMBURSEMENT FROM DIRECTORS		\$ 150.00	\$ 150.00	\$ 150.00	\$ 150.00			\$ 340.56
	Monthly Totals	\$ -	\$ 150.00	\$ 325.34	\$ 150.00	\$ 150.00			\$ -
11/30/15	CAL PERS - HEALTH INS. ASSURANT - DENTAL INS. CSDA,SAN DIEGO CHAPTER WATER AGENCIES ASSOC OF S.D. COUNCIL OF WATER UTILITIES DIRECTORS' MEETINGS MILEAGE EXPENSE REIMBURSEMENT FROM DIRECTORS	\$ 300.00	\$ 450.00	\$ 900.00	\$ 450.00	\$ 600.00			\$ 340.56
	Monthly Totals	\$ 300.00	\$ 450.00	\$ 935.96	\$ 450.00	\$ 600.00			\$ -
12/31/15	CAL PERS - HEALTH INS. ASSURANT - DENTAL INS. CSDA,SAN DIEGO CHAPTER WATER AGENCIES ASSOC OF S.D. COUNCIL OF WATER UTILITIES DIRECTORS' MEETINGS MILEAGE EXPENSE REIMBURSEMENT FROM DIRECTORS	\$ 150.00	\$ 150.00	\$ 150.00	\$ 150.00	\$ 150.00			\$ 340.56
	Monthly Totals	\$ 150.00	\$ 150.00	\$ 150.00	\$ 150.00	\$ 150.00			\$ -

FY 2015-2016

Disbursement Date	Description	Bob Lucy-21	Jack Griffiths-22	Dennis Sanford-25	Helene Brazier-27	Tory Walker-29	Richard Bigley	William Stewart	Paul Christensen
01/31/16	CAL PERS - HEALTH INS. ASSURANT - DENTAL INS. CSDA,SAN DIEGO CHAPTER CSDA TRAINING COUNCIL OF WATER UTILITIES					\$ 25.00			\$ 340.56
	DIRECTORS' MEETINGS	\$ -	\$ 150.00	\$ 300.00	\$ 150.00	\$ 300.00			
	MILEAGE EXPENSE								
	REIMBURSEMENT FROM DIRECTORS								\$ (340.56)
	Monthly Totals	\$ -	\$ 150.00	\$ 300.00	\$ 150.00	\$ 325.00			\$ -
02/28/16	CAL PERS - HEALTH INS. ASSURANT - DENTAL INS. CSDA,SAN DIEGO CHAPTER CSDA TRAINING COUNCIL OF WATER UTILITIES					\$ 25.00			\$ 340.56
	DIRECTORS' MEETINGS		\$ 150.00	\$ 300.00	\$ 150.00	\$ 300.00			
	MILEAGE EXPENSE		\$ 9.18						
	REIMBURSEMENT FROM DIRECTORS								\$ (340.56)
	Monthly Totals	\$ -	\$ 159.18	\$ 300.00	\$ 150.00	\$ 325.00			\$ -
03/31/16	CAL PERS - HEALTH INS. ASSURANT - DENTAL INS. CSDA TRAINING WATER AGENCIES ASSOC OF S.D. COUNCIL OF WATER UTILITIES					\$ 25.00			\$ 340.56
	DIRECTORS' MEETINGS			\$ 300.00	\$ 450.00	\$ 600.00	\$ 150.00	\$ 150.00	
	MILEAGE EXPENSE								
	REIMBURSEMENT FROM DIRECTORS								\$ (340.56)
	Monthly Totals	\$ -	\$ -	\$ 300.00	\$ 450.00	\$ 625.00	\$ 150.00	\$ 150.00	\$ -
04/30/16	CAL PERS - HEALTH INS. ASSURANT - DENTAL INS. CSDA,SAN DIEGO CHAPTER WATER AGENCIES ASSOC OF S.D. COUNCIL OF WATER UTILITIES								\$ 340.56
	DIRECTORS' MEETINGS						\$ 1,123.56		
	MILEAGE EXPENSE								
	REIMBURSEMENT FROM DIRECTORS								\$ (340.56)
	Monthly Totals	\$ -	\$ -	\$ -	\$ -	\$ -	\$ -	\$ 1,123.56	\$ -
05/31/16	CAL PERS - HEALTH INS. ASSURANT - DENTAL INS. VALLEY CENTER MWD CSDA-SAN DIEGO CHAPTER COUNCIL OF WATER UTILITIES					\$ 25.00			\$ 340.56
	DIRECTORS' MEETINGS			\$ 300.00	\$ 150.00	\$ 300.00	\$ 150.00	\$ 150.00	
	MILEAGE EXPENSE								
	REIMBURSEMENT FROM DIRECTORS								\$ (340.56)
	Monthly Totals	\$ -	\$ -	\$ 300.00	\$ 150.00	\$ 325.00	\$ 150.00	\$ 150.00	\$ -
06/30/16	CAL PERS - HEALTH INS. COUNCIL OF WATER UTILITIES VALLEY CENTER MWD WATER AGENCIES ASSOC OF S.D. COUNCIL OF WATER UTILITIES								\$ 340.56
	DIRECTORS' MEETINGS								
	MILEAGE EXPENSE								
	REIMBURSEMENT FROM DIRECTORS								\$ (340.56)
	Monthly Totals	\$ -	\$ -	\$ -	\$ -	\$ -	\$ -	\$ -	\$ -

Bank Reconciliation

Board Audit

User: rrubio
 Printed: 07/14/2016 - 2:54PM
 Date Range: 06/01/2016 - 06/30/2016
 Systems: 'AP'



Check No.	Vendor/Employee	Transaction Description	Date	Amount
Fund: 01 WATER FUND				
Department: 00				
0	ASSURANT EMPLOYEE BENEFITS	Life & Long Term Disability	06/08/2016	3,832.79
0	ASSURANT EMPLOYEE BENEFITS	Life & Long Term Disability	06/30/2016	4,193.67
0	CB&T / ACWA-JPIA	Monthly Health and Vision Insurance -	06/21/2016	75,085.79
0	CHARLES C. SNEED	Reimburse Retired Employee Health I	06/21/2016	363.00
0	EUGENE BUCKLEY	Reimburse Retired Employee Health I	06/21/2016	363.00
0	EUGENE BUCKLEY	Reimburse Retired Employee Health I	06/30/2016	363.00
0	KEVIN MILLER	Reimburse Retired Employee Health In	06/08/2016	726.00
0	PLIC-SBD GRAND ISLAND	Monthly Dental Insurance	06/08/2016	7,140.67
0	PLIC-SBD GRAND ISLAND	Monthly Dental Insurance	06/30/2016	6,855.65
0	RENE BUSH	Reimburse Retired Employee Health I	06/30/2016	726.00
0	SAN DIEGO COUNTY WATER AUT	Wire Transfer for Water Purchases	06/08/2016	2,091,413.33
0	SHERRY MULLENNIX	Reimburse Retired Employee Health I	06/21/2016	600.00
0	SPECIAL DISTRICT RISK	Worker's Compensation Program Annt	06/30/2016	120,100.71
2200	CHUCK FAUST	Reimburse Over Payment on Compute	06/08/2016	5.00
2205	DAVID SEYMOUR	Reimburse Retired Employee Health I	06/08/2016	726.00
2210	FERGUSON WATERWORKS #1083	3/8" Brass 90	06/08/2016	124.42
2219	LENORE HARRISON	Refund on Closed Account - Acct #32-	06/08/2016	50.00
2220	MARGARET THOMAS	Reimburse Retired Employee Health I	06/08/2016	726.00
2225	RENE BUSH	Reimburse Retired Employee Health I	06/08/2016	726.00
52254	JOHN & LAURA DEGEUS	Refund on Closed Account #53-8148-4	06/21/2016	56.38
52259	FERGUSON WATERWORKS #1083	Valve	06/21/2016	6,214.69
52278	WHITE CAP CONSTRUCTION SUP	Red Line Speedcrete	06/21/2016	1,528.22
52281	AMERICAN EXPRESS	Meter Body Box, Meter Lids	06/23/2016	49,428.51
52302	FERGUSON WATERWORKS #1083	Ball Valve	06/30/2016	7,788.47
52318	SYDNEY PECK	Refund on Closed Account #33-3673-1	06/30/2016	295.30
52323	RUSSELL GROSS	Refund for Overpayment on Acct #21-	06/30/2016	271.71
52330	JIM & VALERIE ZAFERIS	Refund on Closed Account - #27-1663	06/30/2016	1,257.85
Total for Department: 00				2,380,962.16
Department: 31 PUMPING				
52273	SAN DIEGO GAS & ELECTRIC	Monthly Gas and Electric Service	06/21/2016	38,312.77
52287	ASTRA INDUSTRIAL SERV.INC	Pump Station 3 - Check Valve Replace	06/30/2016	6,662.03
Total for Department: 31 PUMPING				44,974.80
Department: 32 OPERATIONS				
2196	BAVCO	Water Quality Supplies	06/08/2016	999.75
2206	ED BRADLEY	Reimbursement for Survery of Water M	06/08/2016	675.41
2208	FALLBROOK IRRIGATION SUPPLI	Stake & Straw Wattle	06/08/2016	49.03
2218	JOSEPH PERRIERA	Reimbursement for Survery of Water M	06/08/2016	736.42
2229	SAN DIEGO GAS & ELECTRIC	Monthly Electric Service	06/08/2016	9.20
2233	STEPHEN COFFEY	Reimbursement for Survery of Water M	06/08/2016	748.42
2236	UTILITY SERVICE CO.	Pala Mesa Inspection	06/08/2016	10,543.00
52245	BABCOCK LABORATORIES, INC	Monthly Water Analysis	06/21/2016	2,601.25
52257	FALLBROOK OIL CO	Fuel Deliveries	06/21/2016	651.24
52261	GRAYBAR ELECTRIC COMPANY,	Radio System Nema-4X Upgrade	06/21/2016	6,096.62
52264	JESUS HERNANDEZ	Reimbursement for Survery of Water M	06/21/2016	723.42
52265	JOE'S HARDWARE	Compound Spackling, Paint	06/21/2016	21.11

Check No.	Vendor/Employee	Transaction Description	Date	Amount
52273	SAN DIEGO GAS & ELECTRIC	Monthly Gas and Electric Service	06/21/2016	634.68
52281	AMERICAN EXPRESS	Huntley Pump Station - SCADA Panel	06/23/2016	4,246.36
52282	HOME DEPOT	Super Strong Bungee Cords	06/23/2016	162.23
52294	COKER PUMP & EQUIPMENT COM	North/Northside Reservoir - Spare Rai	06/30/2016	3,864.13
52298	D & H WATER SYSTEMS INC	Morro CL2 Rehab - Tubing	06/30/2016	504.36
52301	FALLBROOK OIL CO	Fuel Deliveries	06/30/2016	940.84
52309	HACH	Digital Conductivity Sensor	06/30/2016	744.53
52312	JOE'S HARDWARE	Blue Granite Hammer Bit, Screws & F	06/30/2016	24.69
52317	ONESOURCE DISTRIBUTORS, LLC	Huntley Pump Station Panel Upgrade	06/30/2016	202.18
52324	RYAN HERCO PRODUCTS CORP	Morro CL2 Rehab - Miscellaneous Pai	06/30/2016	560.86
52325	SAN DIEGO GAS & ELECTRIC	Monthly Electric Charge	06/30/2016	9.48
Total for Department: 32 OPERATIONS				35,749.21
Department: 33 VALVE MAINTENANCE				
2189	AEP CALIFORNIA	Base Plate Computer Stand	06/08/2016	192.00
2192	ART'S TRENCH PLATE &	Trench Plate Rental	06/08/2016	663.00
2216	JOE'S HARDWARE	Screws & Bolts	06/08/2016	8.53
52248	BRYAN ROSE	Reimbursement for Waterworks Distrib	06/21/2016	201.00
52282	HOME DEPOT	Elvations Ocean Blue Carpet	06/23/2016	23.36
Total for Department: 33 VALVE MAINTENANCE				1,087.89
Department: 34 WATER DISTRIBUTION				
0	JOE'S PAVING CO, INC	Asphalt Repairs - Mt. Olympus & Vist	06/08/2016	4,574.60
0	TRAFFIC SAFETY SOLUTIONS, LL	Traffic Control Services - Live Oak Pa	06/30/2016	1,600.00
0	UNDERGROUND SERVICE ALERT	Locate Utilities	06/21/2016	163.50
2192	ART'S TRENCH PLATE &	Trench Plate Rental	06/08/2016	245.00
2204	DARREN MILNER	Reimbursement for Survery of Water M.	06/08/2016	663.00
2217	JOHN MACCARRONE	Reimbursement for Collection System	06/08/2016	201.00
2230	SCOTT TERRELL	Reimbursement for Collection System	06/08/2016	161.00
52251	CO'S TRAFFIC CONTROL, INC.	Rice Canyon & Wild Acres Rd - Traffi	06/21/2016	2,493.00
52252	COUNCIL OF WATER UTILITIES	Darren Milner's Attendance at COWU.	06/21/2016	25.00
52279	WIPER CENTRAL,USA	Wiping Rags	06/21/2016	248.81
52281	AMERICAN EXPRESS	Air Paving Breaker	06/23/2016	7,423.17
52286	ART'S TRENCH PLATE &	Trench Plate Rental	06/30/2016	1,805.80
52313	LIFT-IT MANUFACTURING CO,INC	Tie Down Chain, Nylon Strap	06/30/2016	486.82
Total for Department: 34 WATER DISTRIBUTION				20,090.70
Department: 35 METER SERVICES				
0	PALOMAR BACKFLOW	Backflow Certifications	06/08/2016	13,500.00
0	PALOMAR BACKFLOW	Backflow Certifications	06/21/2016	6,588.00
0	PALOMAR BACKFLOW	Backflow Certifications	06/30/2016	6,690.00
52281	AMERICAN EXPRESS	Itron McLite Antenna Base	06/23/2016	129.60
52293	CHRIS HOELSCHER	Reimbursement for CA-NV-AWWA C	06/30/2016	135.00
52307	GERARDO CANCINO	Reimbursement for Backflow Tester E	06/30/2016	180.00
52315	MEASUREMENT CONTROL SYSTI	Breakaway Hydrant Lock	06/30/2016	791.83
Total for Department: 35 METER SERVICES				28,014.43
Total for Fund:01 WATER FUND				2,510,879.19

Check No.	Vendor/Employee	Transaction Description	Date	Amount
Fund: 02 SEWER FUND				
Department: 00				
2201	CITY OF OCEANSIDE	Sewer Treatment - June 2016	06/08/2016	63,836.54
Total for Department: 00				63,836.54
Department: 61 WASTEWATER				
0	HAAKER EQUIPMENT CO.	Wire Skids	06/21/2016	278.64
2226	RHO MONSERATE C.C.H.A.	Electric Charge	06/08/2016	445.68
2229	SAN DIEGO GAS & ELECTRIC	Monthly Electric Service	06/08/2016	12.00
52242	AIRGAS USA, LLC	Monthly Agreement	06/21/2016	121.71
52245	BABCOCK LABORATORIES, INC	Monthly Water Analysis	06/21/2016	520.00
52246	BALTIC NETWORKS USA	Lift Station #6 - SCADA Panel Replac	06/21/2016	428.62
52260	FRED PRYOR SEMINARS	Ramon Zuniga - Seminar for Leadersh	06/21/2016	249.00
52262	HOUSTON AND HARRIS	Video Sewer Line Pipe Inspections	06/21/2016	14,720.00
52273	SAN DIEGO GAS & ELECTRIC	Monthly Gas and Electric Service	06/21/2016	3,831.21
52281	AMERICAN EXPRESS	Monthly Bin Rental	06/23/2016	210.00
52282	HOME DEPOT	Mixer, Drill Kit	06/23/2016	107.23
52311	INTEGRITY ELECTRIC	Emergency Power Set Up at L/S #2	06/30/2016	12,690.00
52321	RAIN FOR RENT RIVERSIDE	Float Open Complete for Emergency 1	06/30/2016	126.80
52322	RHO MONSERATE C.C.H.A.	Electric Charge	06/30/2016	387.32
52325	SAN DIEGO GAS & ELECTRIC	Monthly Electric Charge	06/30/2016	12.00
Total for Department: 61 WASTEWATER				34,140.21
Total for Fund:02 SEWER FUND				97,976.75

Fund: 03 GENERAL FUND

Department: 00

0	CB&T / ACWA-JPIA	Monthly Health and Vision Insurance -	06/21/2016	2,362.31
52304	FIRST BANKCARD	San Diego County Recorder Fees	06/30/2016	10.50
Total for Department: 00				2,372.81

Department: 20 BOARD

52252	COUNCIL OF WATER UTILITIES	Tory Walker's Attendance at COWUM	06/21/2016	25.00
Total for Department: 20 BOARD				25.00

Department: 36 GARAGE

0	FLYERS ENERGY LLC	Fuel Deliveries	06/30/2016	476.67
0	O'REILLY AUTO PARTS	Shop Supplies	06/30/2016	243.18
0	PARKHOUSE TIRE, INC.	Unit #105 - Tires	06/21/2016	3,307.20
0	PARKHOUSE TIRE, INC.	Unit #131 - Tires	06/30/2016	132.50
2190	ALAN TAYLOR COMPANY	Scent Bags for Rodent Deterent in Dis	06/08/2016	178.20
2207	FALLBROOK AUTO PARTS	Unit #42- Brake Pads, Unit #13 & 53 -	06/08/2016	649.53
2231	SONSRAY MACHINERY LLC.	Precleaner	06/08/2016	74.92
52247	BP BATTERY	Unit #71 - Battery	06/21/2016	317.69
52256	FALLBROOK AUTO PARTS	Fleet Supplies, Uni #104 - Oil& Air Fi	06/21/2016	1,068.58
52257	FALLBROOK OIL CO	Fuel Deliveries	06/21/2016	2,813.08
52266	KEITH KOPITZKE	Payment on District Claim	06/21/2016	2,420.00
52270	NETWORK FLEET, INC.	Monthly Airtime Charges for GPS Tra	06/21/2016	780.00
52272	QUALITY CHEVROLET	Unit #24 - Engine Oil Cooler Line and	06/21/2016	81.13
52277	TRANSWEST SAN DIEGO, INC.	Unit #32 - Relocated Pacific Tek Vacu	06/21/2016	4,307.65
52281	AMERICAN EXPRESS	Traxion Mechanics Creeper	06/23/2016	2,585.06
52284	ALL STAR GLASS	Unit #31 - Windshiled	06/30/2016	211.36
52290	BIRD FAMILY TIRE AND AUTO	Unit #24 - AC Service	06/30/2016	103.17
52291	BP BATTERY	Unit #61 - Battery	06/30/2016	462.32
52295	COMMUNICATIONS SERVICES	Unit #22 - New Radio, Relocate Anten	06/30/2016	612.03
52296	CONTROLLED MOTION SOLUTIO	Assembly	06/30/2016	426.57
52299	FALLBROOK AUTO PARTS	Air Filter	06/30/2016	54.64
52300	FALLBROOK MUFFLER	Unit #4 - Catalytic Converter and Labc	06/30/2016	431.00
52301	FALLBROOK OIL CO	Fuel Deliveries	06/30/2016	2,123.63
52305	FORD OF ESCONDIDO	Unit #37 - Gauge	06/30/2016	1,083.93
52308	GIL FRANCO, TIRE HAULER	Used Tire Disposal	06/30/2016	320.00
52327	TRANSWEST SAN DIEGO, INC.	Unit #33 - Diesel Particulate Filter Clc	06/30/2016	2,328.77
Total for Department: 36 GARAGE				27,592.81

Department: 41 ADMINISTRATION/HR

0	ACCELA, INC. #774375	Travel Expenses for Rochelle Koerner	06/21/2016	1,571.49
0	DATAPROSE INC.	Monthly Mailing of Water Bills and N	06/21/2016	1,027.45
0	IMAGE SOURCE	Monthly Copy Count	06/30/2016	320.18
0	RAFTELIS FINANCIAL CONSULTA	Professional Services - May 2016	06/21/2016	1,120.00
0	RUTAN & TUCKER, LLP	Legal Services - April 2016	06/08/2016	2,537.00
0	RUTAN & TUCKER, LLP	Legal Services - May 2016	06/30/2016	1,770.00
0	SHEPHERD & STAATS, INC.	Administrative Services	06/21/2016	1,250.00
0	SOUTHWEST ANSWERING SERVI	Monthly Answering Service	06/21/2016	795.94
0	SPECIAL DISTRICT RISK	Property/Liability Insurance 2016-201	06/30/2016	193,093.11
0	STREAMLINE	Monthly Web Management Fee	06/08/2016	300.00
0	STREAMLINE	Monthly Web Management Fee	06/30/2016	300.00
0	WESTERN LANDSCAPE MAINT PI	Landscape Maintenance Service	06/08/2016	483.00
0	WESTERN LANDSCAPE MAINT PI	Landscape Maintenance Service	06/30/2016	483.00
2193	AT&T	Monthly Phone Service	06/08/2016	566.01
2194	AT&T LONG DISTANCE	Monthly Phone Service	06/08/2016	16.05
2197	BONSALL CHAMBER OF	Annual Membership	06/08/2016	145.00
2198	BONSALL PEST CONTROL	Monthly Pest Control	06/08/2016	90.00
2202	COVERALL NORTH AMERICA, IN	Kitchen and Bathroom Supplies	06/08/2016	1,609.84

Check No.	Vendor/Employee	Transaction Description	Date	Amount
2208	FALLBROOK IRRIGATION SUPPLI	PVC Pipe	06/08/2016	270.48
2209	FALLBROOK WASTE AND RECYC	Monthly REfuse and Recycle	06/08/2016	335.55
2211	FIRST BANKCARD	Chili's - Tom Kennedy & Bill Stewart	06/08/2016	1,265.02
2212	FIRST BANKCARD	Amazon - Battery for Plantronics	06/08/2016	185.02
2215	IMAGE SOURCE	Monthly Copy Count	06/08/2016	364.10
2222	MISSION VALLEY SANITATION-SI	Port-Potty Rental for Cal Fire Camp W	06/08/2016	179.94
2223	OCCUPATIONAL HEALTH CENTEF	Pre-Employment Exam - Office	06/08/2016	123.00
2224	OFFICE TEAM	Human Resources Temporary Help	06/08/2016	2,388.14
2228	SAN DIEGO COUNTY ASSESSOR/F	Acct #53-8148-4 & #38-3039-5 - Recc	06/08/2016	26.00
2229	SAN DIEGO GAS & ELECTRIC	Monthly Electric Service	06/08/2016	3,606.89
2237	VERIZON WIRELESS	Monthly Cellular Service	06/08/2016	1,799.47
2238	VILLAGE NEWS	Publication of Public Hearing	06/08/2016	100.00
2239	XEROX CORP.	Monthly Lease	06/08/2016	1,474.65
52244	AT&T	Monthly Phone Service	06/21/2016	167.58
52253	CYNTHIA GRAY	Reimbursement for Travel and Meal E	06/21/2016	375.17
52255	EMPLOYEE RELATIONS, INC	Pre-Employment Background Informa	06/21/2016	485.40
52258	FEDEX	Delivery Service	06/21/2016	67.37
52263	IMAGE SOURCE	Service on Copier	06/21/2016	95.00
52268	MITEL LEASING	Lease Agreement	06/21/2016	575.70
52269	MODULAR BUILDING CONCEPTS	Rental Agreement	06/21/2016	726.84
52271	OFFICE TEAM	Human Resources Temporary Help	06/21/2016	4,500.00
52274	SHRED-IT USA LLC	Monthly Service Agreement	06/21/2016	121.28
52275	TEMECULA TROPHY CO.	Name Plates - Michael Powers and Ka	06/21/2016	53.36
52276	TIME WARNER CABLE	Monthly Internet Connection	06/21/2016	1,250.00
52280	XEROX FINANCIAL SERVICES	Monthly Lease	06/21/2016	567.14
52281	AMERICAN EXPRESS	Monthly Uniforms	06/23/2016	15,065.92
52282	HOME DEPOT	Troffer w/lamps, Connectors	06/23/2016	299.21
52283	JENNIFER WISE	Reimbursement for HR Classes	06/28/2016	800.00
52288	AT&T	Monthly Phone Service	06/30/2016	544.37
52289	AT&T LONG DISTANCE	Monthly Phone Service	06/30/2016	16.05
52297	CSDA, SAN DIEGO CHAPTER	CSDA Membership Renewal 2016/201	06/30/2016	150.00
52303	FIRST BANKCARD	Aladdin Airport Parking - Tom Kennec	06/30/2016	551.28
52304	FIRST BANKCARD	Monoprice.com - Newtworking Cable:	06/30/2016	89.69
52312	JOE'S HARDWARE	U Bolts, Bondo Filler	06/30/2016	23.84
52314	ROBERT LO	Employee Relations - Kyle Schilling	06/30/2016	117.89
52316	OFFICE TEAM	Human Resources Temporary Help	06/30/2016	7,535.10
52320	PITNEY BOWES, INC	Lease Agreement	06/30/2016	686.82
52325	SAN DIEGO GAS & ELECTRIC	Monthly Electric Charge	06/30/2016	4,417.64
52326	TEMECULA TROPHY CO.	Years of Service Perpetual	06/30/2016	36.13
52328	VERIZON WIRELESS	Monthly Cellular Service	06/30/2016	3,427.17
52329	WILD ACRES ROAD MAINTENAN	Reimbursement for Wild Acres Road M	06/30/2016	1,466.00

Total for Department: 41 ADMINISTRATION/HR 263,808.28

Department: 43 SAFETY

0	CALIFORNIA COMMERCIAL SECU	Trouble Shoot and Replace Fob Reade	06/08/2016	299.25
0	FIREHAWK FIRE AND SAFETY	Additional Extinguishers and Service	06/21/2016	114.21
0	KNIGHT SECURITY & FIRE SYSTE	Replaced Panic Buttons, Programmed	06/21/2016	351.00
2191	ALERT LOCKSMITH	Repair and re-key Front Door Lock on	06/08/2016	187.49
2227	RUBEN LOPEZ	Reimbursement for Work Safety Boots	06/08/2016	150.00
2234	T.R.Y. ENTERPRISES, INC.	Patrol Services for June - District Yard	06/08/2016	985.00
52241	AIRGAS SAFETY INC	Nylon Duffle Bags	06/21/2016	1,422.18
52243	ALERT LOCKSMITH	Additional Restricted Keys	06/21/2016	28.35
52249	CHRIS HOELSCHER	Reimbursement for Work Safety Boots	06/21/2016	150.00
52250	CHRIS WAITE	Reimbursement for Work Safety Boots	06/21/2016	150.00
52267	LIFELINE RESCUE	CPR/1st Aid/AED Bi-Annual Recertif	06/21/2016	1,890.00
52285	ANDREW ECHOLS	Reimbursement for Safety Work Boots	06/30/2016	80.99
52292	BRIAN FONSECA	Reimbursement for Safety Work Boots	06/30/2016	150.00
52310	HEALTH-METRICS, INC	Annual Hearing Tests	06/30/2016	650.00

Total for Department: 43 SAFETY 6,608.47

Department: 51 FINANCE

Check No.	Vendor/Employee	Transaction Description	Date	Amount
0	DATAPROSE INC.	Monthly Mailing of Water Bills and N	06/21/2016	2,752.36
Total for Department: 51 FINANCE				2,752.36
Department: 52 CUSTOMER SERVICE				
0	DATAPROSE INC.	Monthly Mailing of Water Bills and N	06/21/2016	2,752.10
0	TCN, INC	Monthly 48 Hour Notice Calls	06/08/2016	17.05
2199	CALIFORNIA URBAN CONSERVAI	2016 Membership Dues	06/08/2016	1,402.46
2221	MISSION RESOURCE CONSERVAT	Home Water Use Evaluations - May 20	06/08/2016	453.00
Total for Department: 52 CUSTOMER SERVICE				4,624.61
Department: 91 ENGINEERING				
0	NOBEL SYSTEMS	Software Development Services for Er	06/08/2016	19,600.00
0	PSOMAS	Gird/Monserate Hill Waterline Design	06/08/2016	2,354.75
0	STONEY-MILLER CONSULTANTS,	As-Needed Hydrogeologist Services	06/08/2016	3,571.35
2195	ATKINS NORTH AMERICA, INC	2015 Updates to Water/Wastewater M	06/08/2016	1,832.77
2213	FUSCOE ENGINEERING	Professional Services - April 2016	06/08/2016	9,540.00
2232	STATE OF CA DEPT OF WATER RE:	Beck Dam Fees	06/08/2016	16,372.00
52281	AMERICAN EXPRESS	Realquest Map Search Mortgage, Data	06/23/2016	2,626.50
Total for Department: 91 ENGINEERING				55,897.37
Total for Fund:03 GENERAL FUND				363,681.71

Check No.	Vendor/Employee	Transaction Description	Date	Amount
Fund: 52 SEWER CAPITAL REPLACEMENT				
Department: 00				
0	KENNEDY/JENKS CONSULTANTS	Lift Station 1 Replacement	06/08/2016	24,905.66
0	KENNEDY/JENKS CONSULTANTS	Lift Station 1 Replacement	06/30/2016	24,800.18
2195	ATKINS NORTH AMERICA, INC	2015 Updates to Water/Wastewater M&	06/08/2016	1,832.77
2235	TUCKER APPRAISAL SERVICE CO	Appraisal for Vacant Land Parcel #126	06/08/2016	2,000.00
52281	AMERICAN EXPRESS	Legal Services - General	06/23/2016	5,016.00
Total for Department: 00				58,554.61
Total for Fund:52 SEWER CAPITAL REPLACEMEN				58,554.61

Check No.	Vendor/Employee	Transaction Description	Date	Amount
Fund: 53 SEWER CAPITAL EXPANSION				
Department: 00				
0	TETRA TECH, INC.	As-Needed Construction Support Serv	06/08/2016	20,265.20
2214	HOCH CONSULTING	As-Needed Construction Inspection Se	06/08/2016	870.00
52306	FREEDOM AUTOMATION, INC.	Engineering Services - SCADA Upgra	06/30/2016	2,055.20
Total for Department: 00				23,190.40
Total for Fund:53 SEWER CAPITAL EXPANSION				23,190.40

Check No.	Vendor/Employee	Transaction Description	Date	Amount
Fund: 60 WTR CAP EXPANSION/REPLACEMENT				
Department: 00				
0	DUDEK	Water Reclamation Plant & Recycled	06/21/2016	33,362.50
2192	ART'S TRENCH PLATE &	Trench Plate Rental	06/08/2016	600.00
2203	DAILY JOURNAL CORPORATION	Legal Advertisement for the 215 Urban	06/08/2016	43.40
52306	FREEDOM AUTOMATION, INC.	Engineering Services - SCADA Upgra	06/30/2016	4,795.45
52319	PETERS PAVING & GRADING, INC	Lake Vista Terrace Asphalt Repair	06/30/2016	5,310.00
Total for Department: 00				44,111.35
Total for Fund:60 WTR CAP EXPANSION/REPLAC				44,111.35

Grand Total

3,098,394.01

Comparative Water Sales YTD from Prior Years

FISCAL YEAR 2015-2016

		JUL	AUG	SEP	OCT	NOV	DEC	JAN	FEB	MAR	APR	MAY	JUN	Acre Feet
		29891	26212	33050	25166	24907	20638	12532	10056	19640	18699	22364	28454	624
404	AG	143174	124130	153414	124219	109795	85664	48608	35648	94227	87294	100071	115017	2,804
6	C	4342	3764	4773	2948	1761	665	428	0	0	0	0	0	43
221	CM	28620	33259	34668	28374	14569	11399	8431	8591	11738	13519	20166	35354	571
37	CN	6680	7040	5931	3994	5788	3061	1002	1129	781	2559	2466	5079	104
24	IS	2773	2779	2486	3073	3299	2641	828	796	2141	1784	2271	3340	65
88	MF	11351	10279	10887	9952	9664	8600	8072	6667	7745	8832	8484	10116	254
326	SC	162756	144892	188145	132002	133998	109284	46707	38985	108085	92783	115815	137589	3,239
1038	SD	245736	213120	257965	197426	188412	162042	82599	57837	154618	131816	168901	205591	4,743
5092	SF	148573	143404	162621	135030	120706	96899	69380	52522	95133	95996	110843	142601	3,154
7837	Total	783896	708879	853940	662184	612899	500893	278587	212231	494108	453282	551381	683141	15,600

FISCAL YEAR 2014-2015

Quantity of Meters	User Code	JUL	AUG	SEP	OCT	NOV	DEC	JAN	FEB	MAR	APR	MAY	JUN	Acre Feet
426	A	118146	136346	116938	122567	99702	62354	19943	44790	50073	88589	89259	50899	2,295
341	C	102461	111946	90197	95608	76060	51612	29802	38013	48038	79301	93234	56214	2,003
36	CN	3175	3510	3579	2898	1119	372	1	0	22	1943	2925	8227	64
5558	D	220019	244786	204723	208649	178916	121527	67259	80149	98723	153107	162560	99419	4,224
96	MF	15917	16081	14016	14241	13689	10249	8659	8017	8763	13075	12905	8940	332
323	SC	207708	245358	221301	241409	186106	108701	25015	79139	84982	166849	168519	89560	4,189
1040	SD	284083	332533	282418	297792	260513	165578	46135	109682	137028	236291	250300	134190	5,823
7820	Total	951509	1090560	933172	983164	816105	520393	196814	359790	427629	739155	779702	447449	18,929

FISCAL YEAR 2013-2014

Quantity of Meters	User Code	JUL	AUG	SEP	OCT	NOV	DEC	JAN	FEB	MAR	APR	MAY	JUN	Acre Feet
426	A	130393	132497	140319	122581	96941	51347	71276	81582	56931	61956	110494	123290	2,708
340	C	90317	89194	104313	86744	69704	35242	44886	34899	56147	54616	82751	109178	1,970
36	CN	2965	1618	1737	1857	2284	15	1519	1101	67	798	1706	4044	45
5558	D	225641	246575	245482	210918	178078	101726	123160	142121	107350	114416	190761	224500	4,846
96	MF	14703	17278	17433	14438	14631	9475	11113	9537	9765	9486	14482	17487	367
323	SC	197030	222678	232163	204607	160984	95935	144898	137843	135058	119791	211302	221498	4,784
1040	SD	293327	327443	324488	276743	237162	132450	171852	204192	148580	146423	272782	299556	6,508
7819	Total	954376	1037283	1065935	917888	759784	426190	568704	611275	513898	507486	884278	999553	21,227

Comparative Water Sales YTD from Prior Years

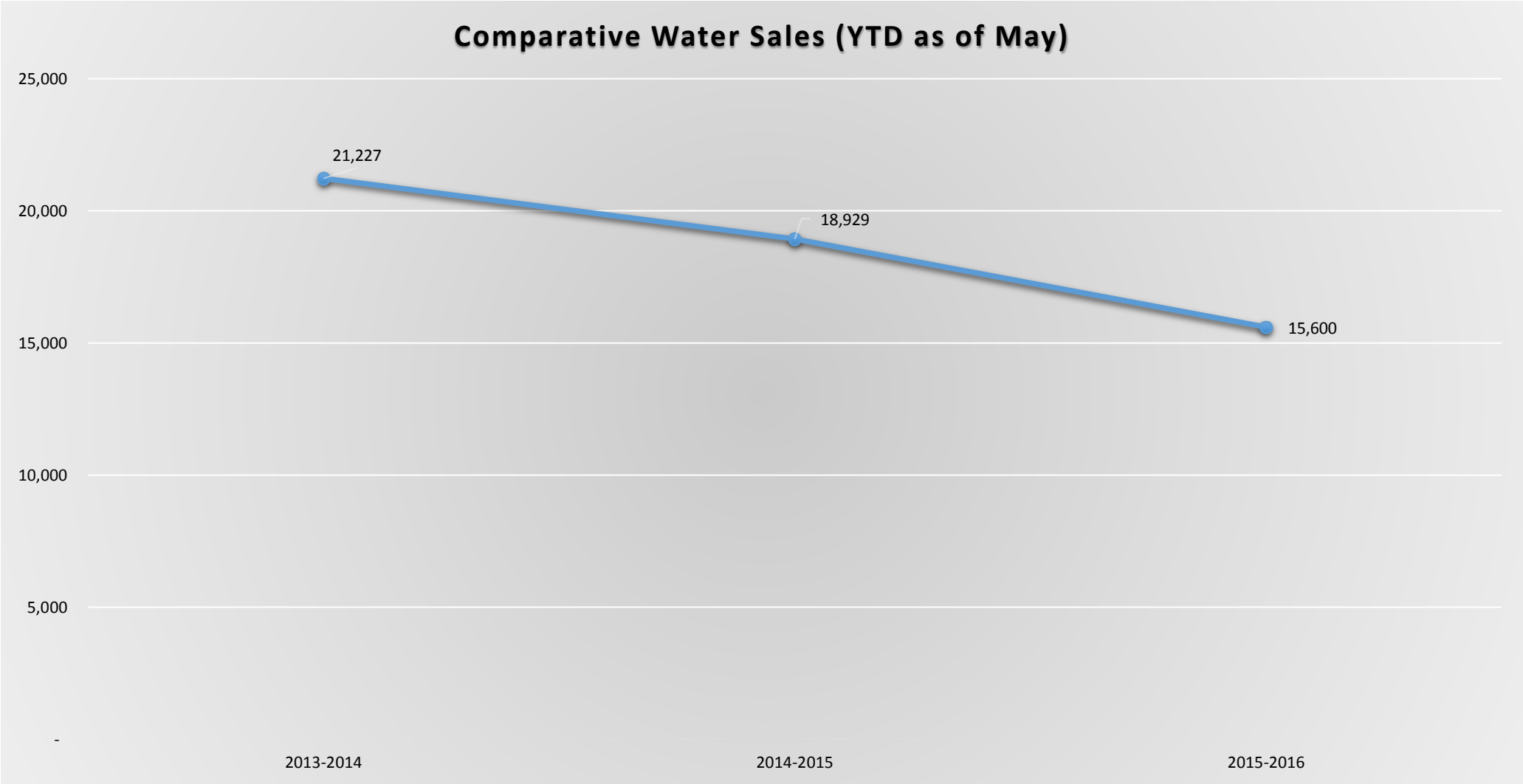

USAGE BY CUSTOMER CLASS FY 15-16

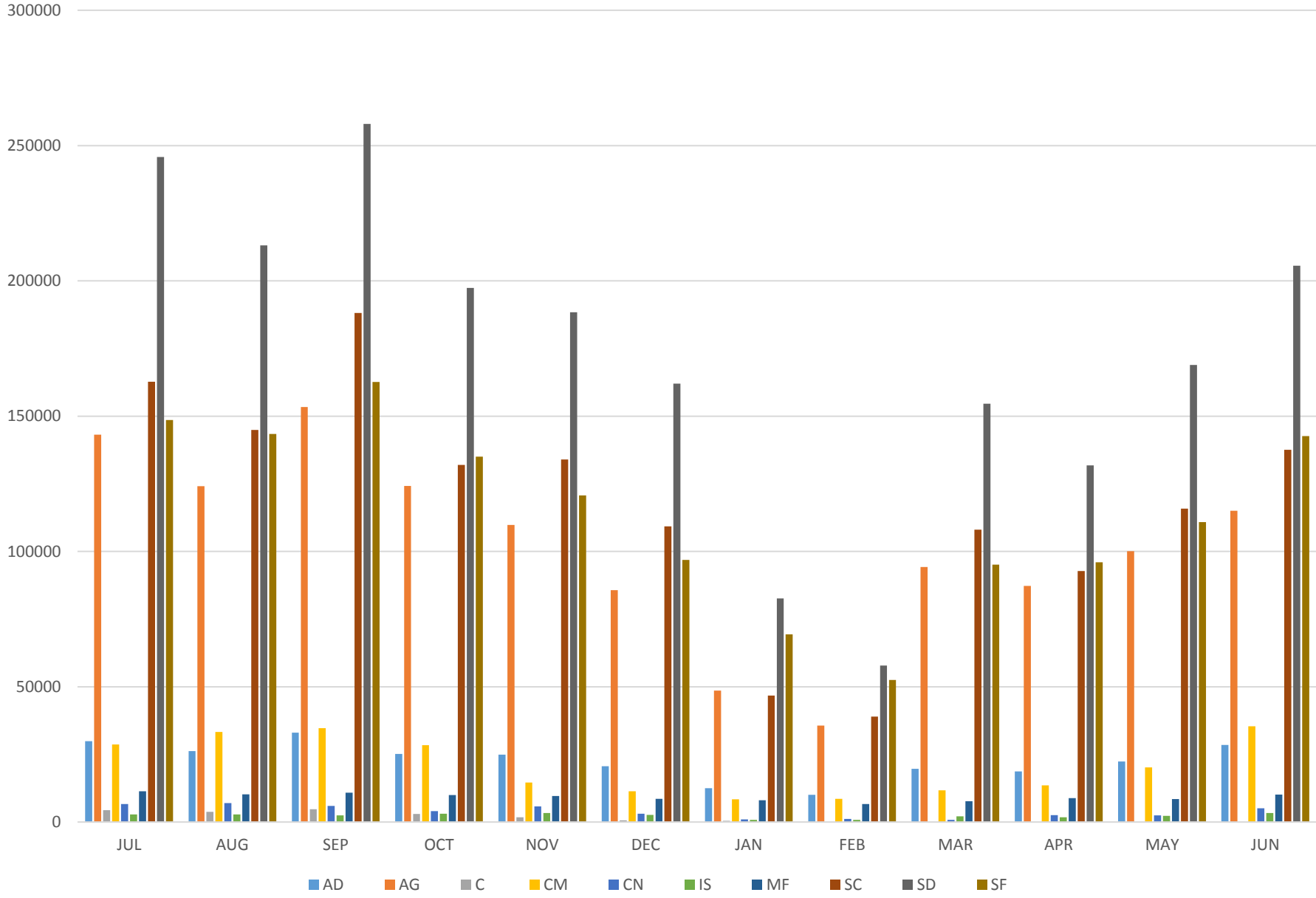



**SEWER EQUIVALENT DWELLING UNITS (EDUs) STATUS REPORT
JUNE 2016**

STATUS SUMMARY	EDUs
Total Treatment Capacity Purchased from Oceanside	8,333.33
Less 5% Contractual Allowance	416.67
EDUs Set Aside by Board for Emergencies	60.00
EDUs Connected	3,901.20
EDUs Unconnected	1,307.24
Total EDUs Available for Purchase:	2,648.23

DEVELOPMENTS WITH UNCONNECTED EDUs	EDUs	CAPACITY FEES PAID
Others (Misc. SFR)	18.40	\$ 270,009
Horse Creek Ridge/ Passarelle	850.57	\$ -
Palomar College	100.00	\$ -
Polo Club (Vista Valley Dev.)	59.85	\$ 1,022,775
Pala Mesa Highlands (Beazer Homes)	124.00	\$ 965,007 *
Golf Green Estates (Dev. Solutions)	102.46	\$ 1,743,180
Lake Vista Estates (Arestad)	2.76	\$ 27,195
Vista Valley Country Club	5.00	\$ 85,450
Silver Holdings	9.00	\$ 153,810
Olive Hill Estates (Pardee Homes)	35.20	\$ 755,378
TOTAL UNCONNECTED:	1,307.24	\$ 5,022,804

*Deferred Total Payment until Building Permits are Issued.

